

# Cross-Validation of SR9011 Hydrochloride Effects with Genetic Models: A Comparative Guide

**Author:** BenchChem Technical Support Team. **Date:** April 2026

## Compound of Interest

Compound Name: SR9011 hydrochloride

CAS No.: 2070014-94-5

Cat. No.: B3049455

[Get Quote](#)

For Researchers, Scientists, and Drug Development Professionals

This guide provides a comprehensive comparison of the pharmacological effects of **SR9011 hydrochloride**, a synthetic Rev-Erb agonist, with genetic models involving the knockout of its target nuclear receptors, Rev-Erb $\alpha$  (NR1D1) and Rev-Erb $\beta$  (NR1D2). The objective is to critically evaluate the on-target effects of SR9011 by cross-validating its observed physiological and gene expression changes with the phenotype of mice lacking one or both Rev-Erb isoforms. This comparative approach is essential for robust target validation and understanding the specificity of action for this class of compounds.

## Core Concepts: Pharmacological vs. Genetic Manipulation

The central aim of this guide is to compare two fundamental approaches in biomedical research for elucidating protein function:

- **Pharmacological Intervention:** The use of a small molecule compound (SR9011) to acutely activate the Rev-Erb nuclear receptors. This approach offers temporal control over protein activity.
- **Genetic Intervention:** The use of knockout (KO) or double knockout (DKO) mouse models where the genes for Rev-Erb $\alpha$  and/or Rev-Erb $\beta$  are permanently deleted. This provides a model of chronic loss-of-function.

A critical consideration in this comparison is the potential for off-target effects of pharmacological agents. Research has indicated that SR9009, a closely related analog of SR9011, can exert effects on cell proliferation and metabolism that are independent of Rev-Erb.[1] This underscores the importance of validating pharmacological findings with genetic models to confirm that the observed effects are indeed mediated by the intended target.

## Comparative Data: SR9011 Effects vs. Rev-Erb Knockout Phenotypes

The following tables summarize quantitative data from studies investigating the effects of SR9011 administration in wild-type mice and the physiological characteristics of Rev-Erb knockout mice.

### Metabolic Parameters

Parameter	SR9011 Treatment in Wild-Type Mice	Rev-Erb $\alpha/\beta$ Double Knockout (DKO) Mice	Key Observations & References
Body Weight	Decreased	No significant change or slight decrease	SR9011 leads to weight loss, an effect not consistently mirrored in DKO mice, suggesting potential Rev-Erb independent or acute pharmacological effects. <a href="#">[2]</a> <a href="#">[3]</a> <a href="#">[4]</a>
Fat Mass	Decreased	Increased hepatic triglycerides	SR9011 reduces adiposity. In contrast, combined Rev-Erb $\alpha/\beta$ deficiency leads to hepatic steatosis (fatty liver), indicating a more complex role for Rev-Erbs in lipid homeostasis. <a href="#">[2]</a> <a href="#">[3]</a> <a href="#">[4]</a> <a href="#">[5]</a>
Oxygen Consumption (Energy Expenditure)	Increased	Altered respiratory exchange ratio (RER)	SR9011 increases energy expenditure. DKO mice show dysregulated metabolism with shifts in substrate utilization, but not a consistent increase in overall oxygen consumption. <a href="#">[2]</a> <a href="#">[3]</a> <a href="#">[4]</a> <a href="#">[6]</a>
Locomotor Activity	Decreased during the active phase	Disrupted circadian rhythm of activity	Both pharmacological activation and genetic deletion of Rev-Erbs

disrupt normal  
patterns of locomotor  
activity, confirming the  
central role of Rev-  
ErbB in regulating  
circadian behavior.[2]  
[7]

---

## Circadian Clock Gene Expression in the Liver

Gene	Effect of SR9011 Treatment (Wild-Type)	Phenotype in Rev-Erb $\alpha/\beta$ DKO	Key Observations & References
Bmal1 (Arntl)	Repressed	De-repressed (expression is increased)	As a direct target of Rev-Erb repression, the opposing effects of SR9011 and genetic knockout on Bmal1 expression provide strong evidence for on-target engagement of SR9011.[5][7]
Clock	Disrupted rhythm	Disrupted rhythm	Both interventions alter the rhythmic expression of Clock, highlighting the integral role of Rev-Erbs in the core circadian oscillator.[7]
Per2	Shifted acrophase	Disrupted rhythm	The phase and rhythm of Per2 expression are sensitive to both acute activation and chronic loss of Rev-Erb function.[7]
Cry1	Less potent effect	De-repressed	While affected, the regulation of Cry1 by Rev-Erbs appears less direct or potent compared to Bmal1.[5]

## Experimental Protocols

## SR9011 Administration in Mice

Objective: To assess the in vivo effects of activating Rev-Erb pharmacologically.

Materials:

- **SR9011 hydrochloride**
- Vehicle solution (e.g., DMSO, PEG400, or a combination)
- Wild-type mice (e.g., C57BL/6J)
- Standard laboratory equipment for intraperitoneal (i.p.) injections

Procedure:

- **SR9011 Formulation:** Dissolve **SR9011 hydrochloride** in the chosen vehicle to the desired concentration (e.g., 10 mg/mL). The final injection volume should be appropriate for the mouse's weight (e.g., 100  $\mu$ L for a 25g mouse to achieve a 40 mg/kg dose).
- **Animal Acclimation:** House mice under a standard 12-hour light:12-hour dark cycle for at least one week before the experiment. Provide ad libitum access to food and water.
- **Dosing Regimen:** Administer SR9011 or vehicle via i.p. injection at a specified time of day (e.g., Zeitgeber Time 6, ZT6). The dosing frequency can be single or multiple times per day depending on the study's objective.
- **Outcome Measures:** Following administration, monitor various parameters such as locomotor activity, body weight, food intake, and collect tissues at specific time points for gene expression or metabolic analysis.

## Generation and Phenotyping of Rev-Erb Knockout Mice

Objective: To create a genetic model of Rev-Erb loss-of-function for comparison with pharmacological activation.

Materials:

- Mice with floxed alleles for Nr1d1 (Rev-Erb $\alpha$ ) and/or Nr1d2 (Rev-Erb $\beta$ )
- Cre-driver mouse line (e.g., a ubiquitously expressing Cre or a tissue-specific Cre)
- Equipment for mouse breeding, genotyping (PCR), and phenotyping.

#### Procedure:

- **Breeding Strategy:** Cross mice carrying the floxed Rev-Erb alleles with mice expressing Cre recombinase. This will result in the excision of the floxed gene segment in the offspring, leading to a knockout.
- **Genotyping:** Confirm the genetic status (wild-type, heterozygous, or homozygous knockout) of the offspring using PCR analysis of genomic DNA isolated from tail biopsies.
- **Phenotypic Analysis:** Characterize the knockout mice by observing their circadian behavior (e.g., wheel-running activity), metabolic parameters (e.g., body weight, glucose tolerance, lipid profiles), and gene expression in various tissues.
- **Comparison:** Compare the phenotype of the knockout mice to that of wild-type littermates to identify the physiological consequences of Rev-Erb deficiency.

## Visualizing Pathways and Workflows

### Rev-Erb Signaling Pathway

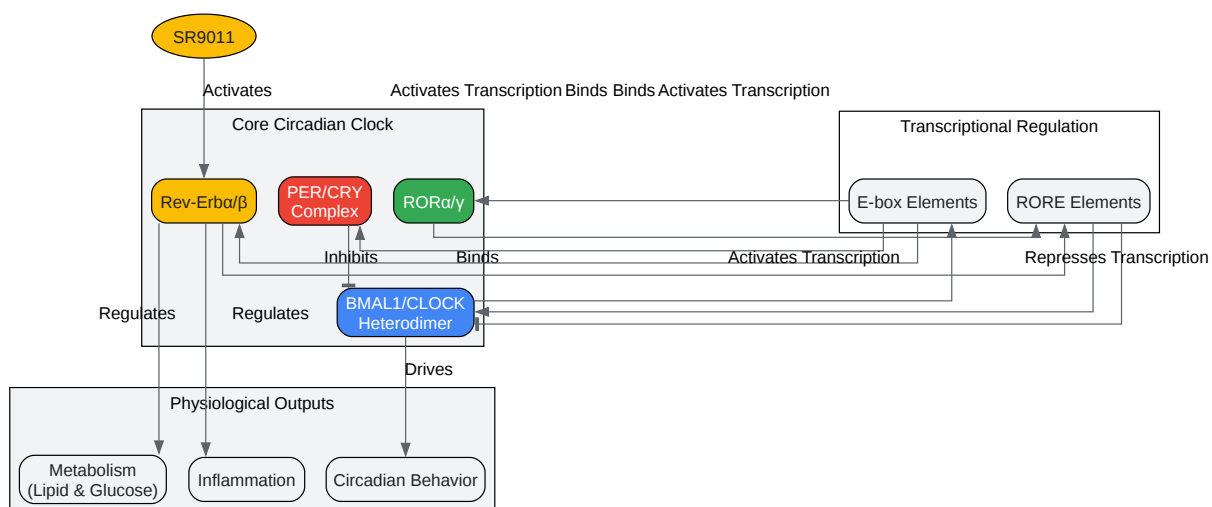

[Click to download full resolution via product page](#)

Caption: The core circadian clock and the regulatory role of Rev-Erb.

## Experimental Workflow for Cross-Validation

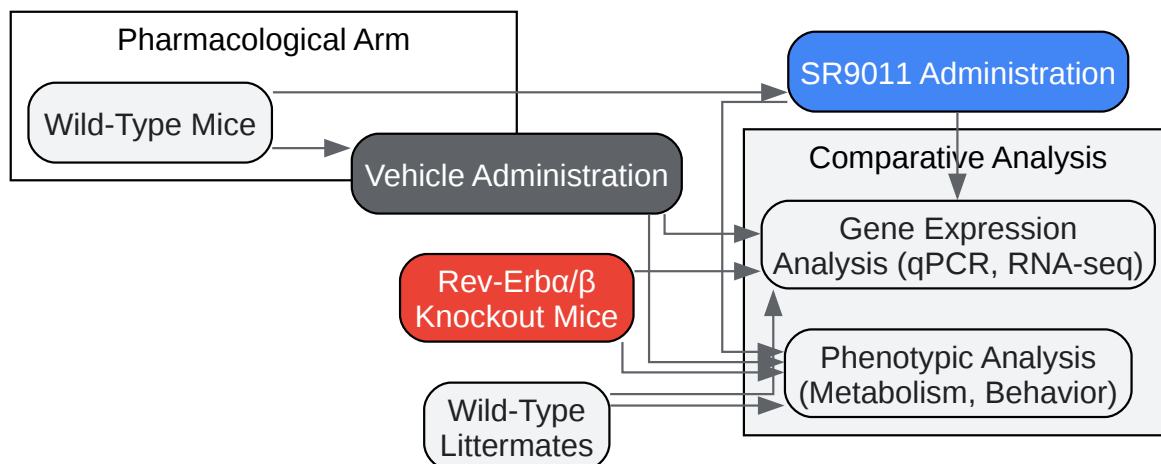

[Click to download full resolution via product page](#)

Caption: Workflow for cross-validating SR9011 effects with genetic models.

## Conclusion

The cross-validation of SR9011's effects with Rev-Erb genetic knockout models is a powerful strategy for confirming its on-target activity and understanding the broader physiological roles of the Rev-Erb nuclear receptors. While SR9011 largely recapitulates many aspects of Rev-Erb's known functions in regulating circadian rhythms and metabolism, discrepancies in phenotypes, such as those related to fat mass and overall energy expenditure, highlight the complexities of acute pharmacological intervention versus chronic genetic deletion.

Furthermore, the potential for Rev-Erb-independent effects of SR9011 necessitates careful interpretation of experimental data and reinforces the importance of using genetic models as a benchmark for target validation in drug discovery. This integrated approach provides a more complete and nuanced understanding of the therapeutic potential and limitations of targeting the Rev-Erb signaling pathway.

### Need Custom Synthesis?

BenchChem offers custom synthesis for rare earth carbides and specific isotopic labeling.

Email: [info@benchchem.com](mailto:info@benchchem.com) or [Request Quote Online](#).

## References

- [1. pnas.org \[pnas.org\]](#)
- [2. Regulation of Circadian Behavior and Metabolism by Synthetic REV-ERB Agonists - PMC \[pmc.ncbi.nlm.nih.gov\]](#)
- [3. researchgate.net \[researchgate.net\]](#)
- [4. researchgate.net \[researchgate.net\]](#)
- [5. Rev-erb \$\alpha\$  and Rev-erb \$\beta\$  coordinately protect the circadian clock and normal metabolic function - PMC \[pmc.ncbi.nlm.nih.gov\]](#)
- [6. researchgate.net \[researchgate.net\]](#)
- [7. The Effect of Rev-erb \$\alpha\$  Agonist SR9011 on the Immune Response and Cell Metabolism of Microglia - PMC \[pmc.ncbi.nlm.nih.gov\]](#)
- To cite this document: BenchChem. [Cross-Validation of SR9011 Hydrochloride Effects with Genetic Models: A Comparative Guide]. BenchChem, [2026]. [Online PDF]. Available at: [\[https://www.benchchem.com/product/b3049455/docs#cross-validation-of-sr9011-hydrochloride-effects-with-genetic-models-a-comparative-guide\]](https://www.benchchem.com/product/b3049455/docs#cross-validation-of-sr9011-hydrochloride-effects-with-genetic-models-a-comparative-guide)

---

### Disclaimer & Data Validity:

The information provided in this document is for Research Use Only (RUO) and is strictly not intended for diagnostic or therapeutic procedures. While BenchChem strives to provide accurate protocols, we make no warranties, express or implied, regarding the fitness of this product for every specific experimental setup.

**Technical Support:** The protocols provided are for reference purposes. Unsure if this reagent suits your experiment?

**Need Industrial/Bulk Grade?** [Request Custom Synthesis Quote](#)

# BenchChem

Our mission is to be the trusted global source of essential and advanced chemicals, empowering scientists and researchers to drive progress in science and industry.

## Contact

Address: 3281 E Guasti Rd

Ontario, CA 91761, United States

Phone: (601) 213-4426

Email: [info@benchchem.com](mailto:info@benchchem.com)

[Contact our Ph.D. Support Team for a compatibility check](#)