

Synthesis of Heterocyclic Compounds Using Dimethyl 2,4-Dioxopentanedioate: Application Notes and Protocols

Author: BenchChem Technical Support Team. **Date:** May 2026

Compound of Interest

Compound Name:	Dimethyl 2,4-dioxopentanedioate
CAS No.:	162253-71-6
Cat. No.:	B3048244

[Get Quote](#)

For Researchers, Scientists, and Drug Development Professionals

Introduction: The Versatility of Dimethyl 2,4-Dioxopentanedioate as a Heterocyclic Precursor

Dimethyl 2,4-dioxopentanedioate, also known as dimethyl acetonedioxalate, is a highly versatile and reactive precursor in the synthesis of a wide array of heterocyclic compounds. Its 1,3-dicarbonyl moiety provides two electrophilic centers, making it an ideal substrate for cyclocondensation reactions with various nucleophiles. This reactivity allows for the construction of diverse and complex molecular scaffolds, which are of significant interest in medicinal chemistry and drug discovery. The pyridine, pyrimidine, and pyrazole cores, for instance, are privileged structures found in numerous natural products and pharmaceuticals.^[1] This guide provides detailed application notes and protocols for the synthesis of these important classes of heterocycles using **dimethyl 2,4-dioxopentanedioate** as a key building block.

I. Synthesis of Pyridine Derivatives via Hantzsch-Type Reaction

The Hantzsch pyridine synthesis is a classic multi-component reaction that typically involves the condensation of an aldehyde, two equivalents of a β -ketoester, and a nitrogen donor, such as ammonia or ammonium acetate.[1] The initial product is a 1,4-dihydropyridine, which can then be oxidized to the corresponding aromatic pyridine.[2] The use of **dimethyl 2,4-dioxopentanedioate** in this reaction allows for the synthesis of novel pyridine derivatives with unique substitution patterns that may exhibit interesting pharmacological properties.[1]

Reaction Rationale and Mechanistic Insight

The reaction proceeds through a series of condensations and additions. Initially, one molecule of **dimethyl 2,4-dioxopentanedioate** condenses with the aldehyde in a Knoevenagel condensation. A second molecule of the dicarbonyl compound reacts with the ammonia source to form an enamine. These two intermediates then undergo a Michael addition, followed by cyclization and dehydration to yield the 1,4-dihydropyridine ring. The final step is an oxidation to achieve the stable aromatic pyridine ring. The choice of solvent and catalyst can influence reaction times and yields. While classical methods often require harsh conditions and long reaction times, modern protocols have been optimized for efficiency.

Visualizing the Hantzsch Pyridine Synthesis

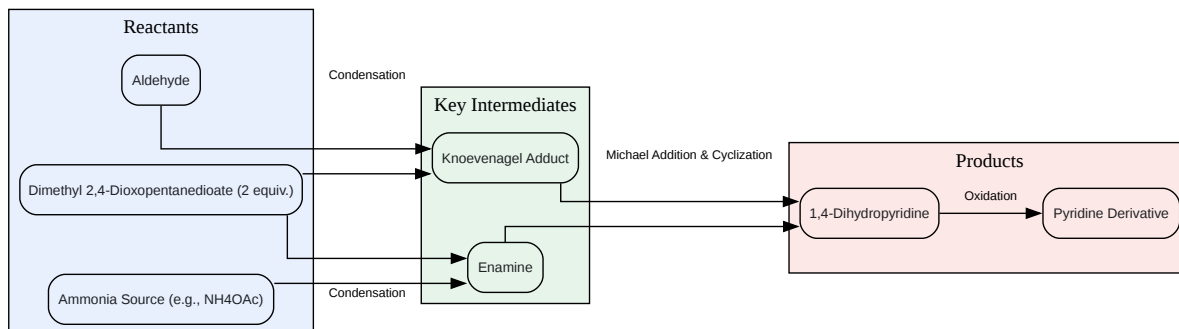

[Click to download full resolution via product page](#)

Caption: Generalized workflow of the Hantzsch pyridine synthesis.

Experimental Protocol: Synthesis of Dimethyl 4-phenyl-2,6-bis(methoxycarbonyl)-1,4-dihydropyridine-3,5-dicarboxylate

This protocol is adapted from a similar synthesis using the corresponding ethyl ester.^[1]

Materials:

- **Dimethyl 2,4-dioxopentanedioate** (2.0 mmol)
- Benzaldehyde (1.0 mmol)
- Ammonium acetate (1.2 mmol)
- Ethanol (20 mL)
- Ethyl acetate

- Hexane
- Water (deionized)
- Brine
- Anhydrous sodium sulfate
- Silica gel for column chromatography

Equipment:

- 100 mL round-bottom flask
- Magnetic stir bar
- Reflux condenser
- Heating mantle
- Rotary evaporator
- Separatory funnel
- Chromatography column
- Thin-layer chromatography (TLC) plates and chamber

Procedure:

- To a 100 mL round-bottom flask equipped with a magnetic stir bar, add **dimethyl 2,4-dioxopentanedioate** (2.0 mmol), benzaldehyde (1.0 mmol), and ammonium acetate (1.2 mmol).
- Add 20 mL of ethanol to the flask.
- Attach a reflux condenser and heat the reaction mixture to reflux (approximately 80°C) with vigorous stirring.

- Monitor the progress of the reaction by thin-layer chromatography (TLC) using a mixture of ethyl acetate and hexane as the eluent.
- Once the reaction is complete (typically after 4-6 hours), allow the mixture to cool to room temperature.
- Remove the ethanol under reduced pressure using a rotary evaporator.
- Dissolve the residue in ethyl acetate (30 mL) and transfer to a separatory funnel.
- Wash the organic layer with water (2 x 20 mL) and then with brine (20 mL).
- Dry the organic layer over anhydrous sodium sulfate, filter, and concentrate under reduced pressure.
- Purify the crude product by column chromatography on silica gel using a gradient of ethyl acetate in hexane as the eluent to afford the pure 1,4-dihydropyridine product.

Oxidation to the Pyridine Derivative:

The resulting 1,4-dihydropyridine can be aromatized to the corresponding pyridine using various oxidizing agents, such as iodine in methanol or nitric acid.^[2]

II. Synthesis of Pyrimidine Derivatives via Biginelli-Type Reaction

The Biginelli reaction is a multi-component synthesis of 3,4-dihydropyrimidin-2(1H)-ones from an aldehyde, a β -ketoester, and urea.^[3] This acid-catalyzed cyclocondensation provides a straightforward route to a class of compounds with a wide range of biological activities. By employing **dimethyl 2,4-dioxopentanedioate**, novel dihydropyrimidine derivatives can be accessed.

Reaction Rationale and Mechanistic Insight

The mechanism of the Biginelli reaction is believed to begin with the acid-catalyzed condensation of the aldehyde and urea to form an N-acylimine ion. This is followed by the nucleophilic addition of the enol form of **dimethyl 2,4-dioxopentanedioate**. Subsequent

cyclization via intramolecular condensation and dehydration yields the dihydropyrimidine product. Various Brønsted and Lewis acids can be used to catalyze the reaction.

Visualizing the Biginelli-Type Reaction

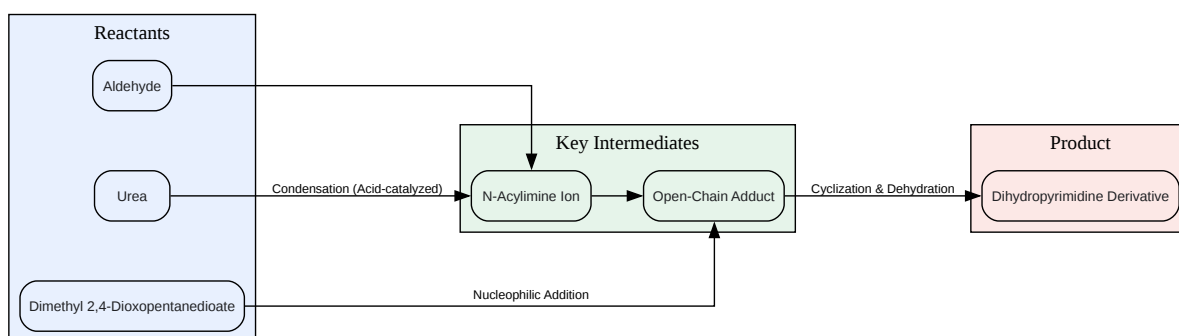

[Click to download full resolution via product page](#)

Caption: Key steps in the Biginelli-type synthesis of dihydropyrimidines.

Experimental Protocol: General Procedure for the Synthesis of Dihydropyrimidine Derivatives

Materials:

- **Dimethyl 2,4-dioxopentanedioate** (1.0 mmol)
- Aromatic aldehyde (1.0 mmol)
- Urea (1.5 mmol)
- Ethanol (15 mL)
- Concentrated Hydrochloric Acid (catalytic amount)

- Ice-water

Equipment:

- 50 mL round-bottom flask
- Magnetic stir bar
- Reflux condenser
- Heating mantle
- Buchner funnel and filter paper

Procedure:

- In a 50 mL round-bottom flask, dissolve **dimethyl 2,4-dioxopentanedioate** (1.0 mmol), the chosen aromatic aldehyde (1.0 mmol), and urea (1.5 mmol) in ethanol (15 mL).
- Add a catalytic amount of concentrated hydrochloric acid (2-3 drops) to the mixture.
- Attach a reflux condenser and heat the reaction mixture to reflux with stirring for 3-4 hours.
- Monitor the reaction progress using TLC.
- After completion, cool the reaction mixture to room temperature and then pour it into ice-water with stirring.
- Collect the precipitated solid by vacuum filtration using a Buchner funnel.
- Wash the solid with cold water and then a small amount of cold ethanol.
- Recrystallize the crude product from a suitable solvent (e.g., ethanol or ethanol/water mixture) to obtain the pure dihydropyrimidine derivative.

III. Synthesis of Pyrazole Derivatives

Pyrazoles are a class of five-membered heterocyclic compounds containing two adjacent nitrogen atoms. They are synthesized through the cyclocondensation of a 1,3-dicarbonyl

compound with a hydrazine derivative.[4] The regioselectivity of the reaction is a key consideration, as unsymmetrical dicarbonyls can potentially yield two different pyrazole isomers.

Reaction Rationale and Mechanistic Insight

The reaction is initiated by the nucleophilic attack of one of the nitrogen atoms of the hydrazine onto one of the carbonyl carbons of **dimethyl 2,4-dioxopentanedioate**. This is followed by an intramolecular cyclization via the attack of the second nitrogen atom on the remaining carbonyl group, and subsequent dehydration to form the aromatic pyrazole ring. The reaction is often carried out in a protic solvent like ethanol or acetic acid, and can be catalyzed by acids.[5][6]

Visualizing the Pyrazole Synthesis

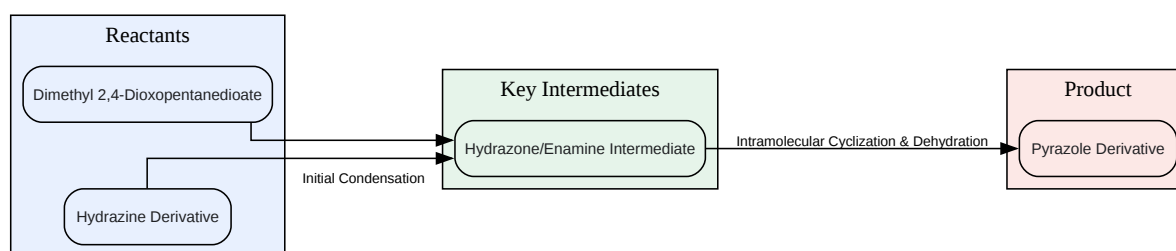

[Click to download full resolution via product page](#)

Caption: General pathway for the synthesis of pyrazoles from a 1,3-dicarbonyl compound.

Experimental Protocol: General Procedure for the Synthesis of Pyrazole Derivatives

Materials:

- **Dimethyl 2,4-dioxopentanedioate** (1.0 mmol)
- Hydrazine hydrate or a substituted hydrazine (e.g., phenylhydrazine) (1.0 mmol)

- Glacial acetic acid (10 mL)
- Ice-water

Equipment:

- 50 mL round-bottom flask
- Magnetic stir bar
- Reflux condenser
- Heating mantle
- Beaker
- Buchner funnel and filter paper

Procedure:

- In a 50 mL round-bottom flask, dissolve **dimethyl 2,4-dioxopentanedioate** (1.0 mmol) and the selected hydrazine derivative (1.0 mmol) in glacial acetic acid (10 mL).
- Attach a reflux condenser and heat the mixture to reflux with stirring for 2-3 hours.
- Monitor the reaction by TLC until the starting materials are consumed.
- After completion, allow the reaction mixture to cool to room temperature.
- Pour the cooled solution into a beaker containing ice-water, which should induce precipitation of the product.
- Collect the solid product by vacuum filtration.
- Wash the precipitate with ample cold water to remove any residual acetic acid.
- Recrystallize the crude pyrazole from a suitable solvent (e.g., ethanol) to yield the purified product.

Quantitative Data Summary

Reaction Type	Key Reactants	Typical Solvent	Catalyst	Typical Reaction Time
Hantzsch Pyridine Synthesis	Aldehyde, NH ₄ OAc	Ethanol	None (thermal)	4-6 hours
Biginelli-Type Pyrimidine Synthesis	Aldehyde, Urea	Ethanol	HCl (catalytic)	3-4 hours
Pyrazole Synthesis	Hydrazine derivative	Acetic Acid	None (acidic medium)	2-3 hours

Conclusion

Dimethyl 2,4-dioxopentanedioate serves as a valuable and versatile C5 synthon for the construction of medicinally relevant heterocyclic cores. The protocols outlined in this guide for the synthesis of pyridines, pyrimidines, and pyrazoles are robust and can be adapted for the creation of diverse compound libraries. The straightforward nature of these multi-component reactions, coupled with the potential for generating novel molecular architectures, makes **dimethyl 2,4-dioxopentanedioate** an attractive starting material for researchers in drug discovery and development.

References

- Arkivoc. (2011). Recent advances in the synthesis of new pyrazole derivatives. [\[Link\]](#)
- Elguero, J., Goya, P., Jagerovic, N., & Silva, A. M. S. (2018). Synthesis and Pharmacological Activities of Pyrazole Derivatives: A Review. *Molecules*, 23(1), 134. [\[Link\]](#)
- Organic Chemistry Portal. (n.d.). Pyridine synthesis. Retrieved from [\[Link\]](#)
- Dar, A. M., & Shamsuzzaman. (2015). A Concise Review on the Synthesis of Pyrazole Heterocycles.

- Aggarwal, N., Kumar, R., & Dureja, P. (2023). Recent Advances in the Synthesis of Pyrazole Derivatives: A Review. *Molecules*, 28(17), 6429. [[Link](#)]
- International Journal of Frontiers in Medicine and Research. (2026).
- Bergman, J., & Wulff, W. D. (2010). The Synthesis of Dihydropyridines and Pyridines from Imines and Alkynes via C-H Activation. *The Journal of organic chemistry*, 75(17), 5895–5903.
- Kumar, R., Singh, H., Mazumder, A., Salahuddin, Bushi, G., & Gaidhane, S. (2024). Recently Adopted Synthetic Approaches to Pyridine and Analogs: A Review. *Indian Journal of Pharmaceutical Sciences*, 86(4), 1187-1198.
- Organic Chemistry Portal. (n.d.). Pyrimidine synthesis. Retrieved from [[Link](#)]
- Yoneda, F., & Higuchi, M. (1977). CONVENIENT SYNTHESIS OF PYRIDO[4,3-d]PYRIMIDINE-2,4-DIONES. *Journal of the Chemical Society, Perkin Transactions 1*, (12), 1336-1339.
- Mansoura University. (n.d.).
- Bagley, M. C., Dale, J. W., & Bower, J. (2013). One-step synthesis of pyridines and dihydropyridines in a continuous flow microwave reactor. *Beilstein Journal of Organic Chemistry*, 9, 2095–2102. [[Link](#)]
- Ryzhkova, Y., Ryzhkov, F., Maslov, O., & Elinson, M. N. (2022). Multicomponent Synthesis of 2-(2,4-Diamino-3-cyano-5H-chromeno[2,3-b]pyridin-5-yl)malonic Acids in DMSO. *Molecules*, 27(10), 3249. [[Link](#)]
- Ryzhkova, Y., Maslov, O., & Elinson, M. N. (2021). Dimethyl 2-(2,4-Diamino-3-cyano-5H-chromeno[2,3-b]pyridin-5-yl)malonate. *Molbank*, 2022(1), M1310. [[Link](#)]
- International Journal of Pharmaceutical Science Invention. (2022).
- Beilstein-Institut. (2025).
- Scribd. (n.d.). Synthesis of Pyrimidine Derivatives. [[Link](#)9/Synthesis-of-Pyrimidine-Derivatives)

Need Custom Synthesis?

BenchChem offers custom synthesis for rare earth carbides and specific isotopic labeling.

Email: info@benchchem.com or [Request Quote Online](#).

Sources

- [1. pdf.benchchem.com \[pdf.benchchem.com\]](https://pdf.benchchem.com)
- [2. Pyridine synthesis \[organic-chemistry.org\]](https://www.organic-chemistry.org)
- [3. scribd.com \[scribd.com\]](https://www.scribd.com)
- [4. Synthesis and Pharmacological Activities of Pyrazole Derivatives: A Review - PMC \[pmc.ncbi.nlm.nih.gov\]](https://pubmed.ncbi.nlm.nih.gov/)
- [5. hilarispublisher.com \[hilarispublisher.com\]](https://www.hilarispublisher.com)
- [6. mdpi.com \[mdpi.com\]](https://www.mdpi.com)
- To cite this document: BenchChem. [Synthesis of Heterocyclic Compounds Using Dimethyl 2,4-Dioxopentanedioate: Application Notes and Protocols]. BenchChem, [2026]. [Online PDF]. Available at: [<https://www.benchchem.com/product/b3048244/docs#synthesis-of-heterocyclic-compounds-using-dimethyl-2-4-dioxopentanedioate-application-notes-and-protocols>]

Disclaimer & Data Validity:

The information provided in this document is for Research Use Only (RUO) and is strictly not intended for diagnostic or therapeutic procedures. While BenchChem strives to provide accurate protocols, we make no warranties, express or implied, regarding the fitness of this product for every specific experimental setup.

Technical Support: The protocols provided are for reference purposes. Unsure if this reagent suits your experiment?

Need Industrial/Bulk Grade? [Request Custom Synthesis Quote](#)

BenchChem

Our mission is to be the trusted global source of essential and advanced chemicals, empowering scientists and researchers to drive progress in science and industry.

Contact

Address: 3281 E Guasti Rd

Ontario, CA 91761, United States

Phone: (601) 213-4426

Email: info@benchchem.com

Contact our Ph.D. Support Team for a compatibility check