

Comparative Guide: Structure-Activity Relationship (SAR) of Indolyl-1,2,4-Triazole Derivatives

Author: BenchChem Technical Support Team. **Date:** April 2026

Compound of Interest

Compound Name:	3-(1H-indol-3-yl)-1H-1,2,4-triazol-5-amine
CAS No.:	1374407-88-1
Cat. No.:	B3047309

[Get Quote](#)

Executive Summary: The Hybrid Scaffold Advantage

Target Audience: Medicinal Chemists, Pharmacologists, and Drug Discovery Leads.

The fusion of the indole nucleus (a privileged scaffold found in tryptophan and serotonin) with the 1,2,4-triazole ring (a pharmacophore central toazole antifungals and kinase inhibitors) creates a versatile hybrid system. Unlike single-scaffold drugs, Indolyl-1,2,4-triazole derivatives offer a dual-targeting mechanism, capable of bridging the hydrophobic pockets of kinases or tubulin while simultaneously engaging hydrogen-bonding networks via the triazole nitrogen atoms.

This guide objectively compares these hybrid derivatives against standard-of-care (SoC) agents in two primary therapeutic domains: Anticancer (Tubulin/Kinase inhibition) and Antimicrobial (Antifungal/Antibacterial).

Comparative Analysis: Indolyl-Triazoles vs. Standard Agents[1][2]

Scenario A: Anticancer Potency (Tubulin Polymerization Inhibition)

The Benchmark: Combretastatin A-4 (CA-4) and Colchicine. The Challenger: 3,4,5-Trimethoxyphenyl-Indolyl-1,2,4-Triazoles.[1]

Mechanism: These derivatives bind to the colchicine-binding site of tubulin, disrupting microtubule assembly and causing G2/M cell cycle arrest.

Feature	Standard Agent (CA-4 / Colchicine)	Indolyl-1,2,4- Triazole Derivatives (e.g., Compound 7i)	Comparative Insight
IC50 (Tubulin Inhibition)	1.0 – 2.5 μM	1.6 – 3.0 μM	Hybrids achieve comparable potency to CA-4 but often with better metabolic stability due to the triazole ring replacing the unstable cis-stilbene of CA-4.
Cytotoxicity (HeLa/MCF-7)	IC50: ~0.01 – 0.05 μM	IC50: 0.012 – 0.23 μM	Top-tier hybrids (e.g., 7i) approach nanomolar potency, mimicking the pharmacophore of CA-4.
Selectivity (Normal Cells)	Low (High toxicity)	Moderate to High	Indole hybrids often show reduced toxicity toward normal HEK-293 cells (IC50 > 100 μM) compared to classic tubulin poisons.
Solubility	Poor (Lipophilic)	Improved	The polar triazole ring enhances water solubility compared to purely carbocyclic tubulin inhibitors.

Key Data Point: A 3,4,5-trimethoxyphenyl substitution at the triazole C3/C5 position is critical. It mimics the A-ring of Colchicine, fitting precisely into the hydrophobic pocket of

-tubulin [1, 3].

Scenario B: Antifungal Efficacy (CYP51 / DNA Gyrase Targeting)

The Benchmark: Fluconazole. [2] The Challenger: Halogenated Indolyl-1,2,4-Triazoles.

Feature	Standard Agent (Fluconazole)	Indolyl-1,2,4-Triazole Derivatives (e.g., Compound 6f)	Comparative Insight
MIC (<i>C. albicans</i>)	0.25 – 64 µg/mL (Resistance common)	2 – 4 µg/mL	Hybrids are effective against some Fluconazole-resistant strains due to the bulkier indole group interacting with additional residues in the CYP51 active site.
Spectrum	Broad (Yeasts)	Dual (Fungal + Bacterial)	Unlike Fluconazole (purely antifungal), these hybrids often possess antibacterial activity (DNA Gyrase inhibition) due to the indole moiety [2, 4].
Resistance Profile	High (Efflux pumps)	Lower (Novel binding mode)	The hybrid scaffold is less susceptible to common azole efflux pumps in <i>C. krusei</i> .

Deep Dive: Structure-Activity Relationship (SAR) Logic

To design a potent derivative, one must manipulate four key zones of the scaffold. The following decision tree visualizes the causality between structural modifications and biological

outcomes.

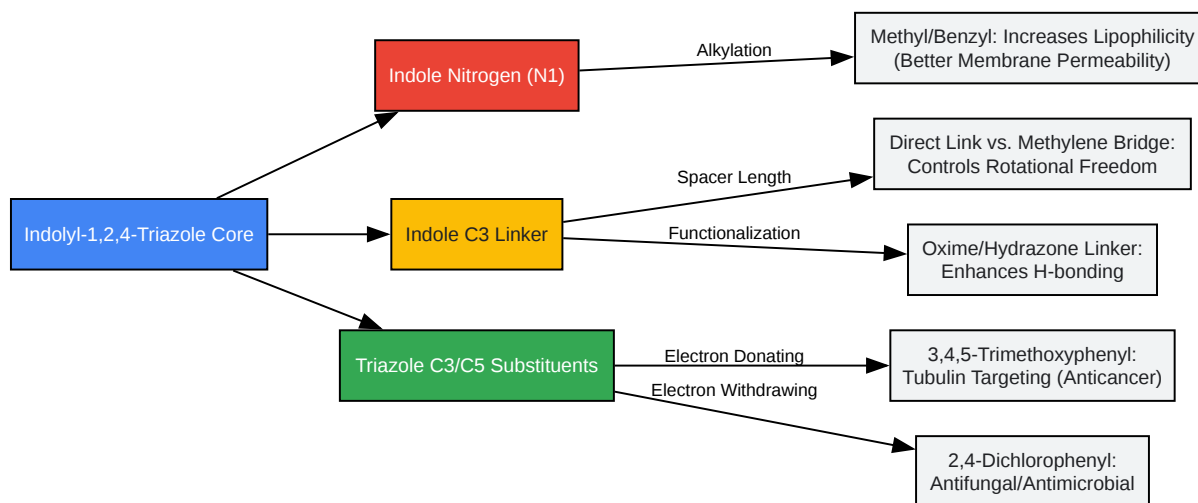

[Click to download full resolution via product page](#)

Figure 1: SAR Decision Tree. Blue node represents the core scaffold; Red, Yellow, and Green nodes represent modifiable zones; Grey nodes represent biological consequences.

Critical SAR Rules:

- The "Colchicine Rule" (Anticancer): For tubulin inhibition, a 3,4,5-trimethoxyphenyl group attached to the triazole is non-negotiable. It provides the necessary steric bulk and electron density to occupy the colchicine binding site [1, 3].
- The "Halogen Rule" (Antimicrobial): Electron-withdrawing groups (Cl, F) on the phenyl ring attached to the triazole significantly enhance antimicrobial potency by increasing lipophilicity and facilitating penetration of the fungal cell wall [2, 4].
- The Linker Effect: Direct attachment of the triazole to the indole C3 position often yields rigid analogs suitable for kinase inhibition (e.g., EGFR), whereas a methylene linker provides the flexibility needed for DNA intercalation or enzyme active sites [5].

Experimental Protocols

Chemical Synthesis Workflow

The most robust method for synthesizing these hybrids involves the cyclization of indole-hydrazides.

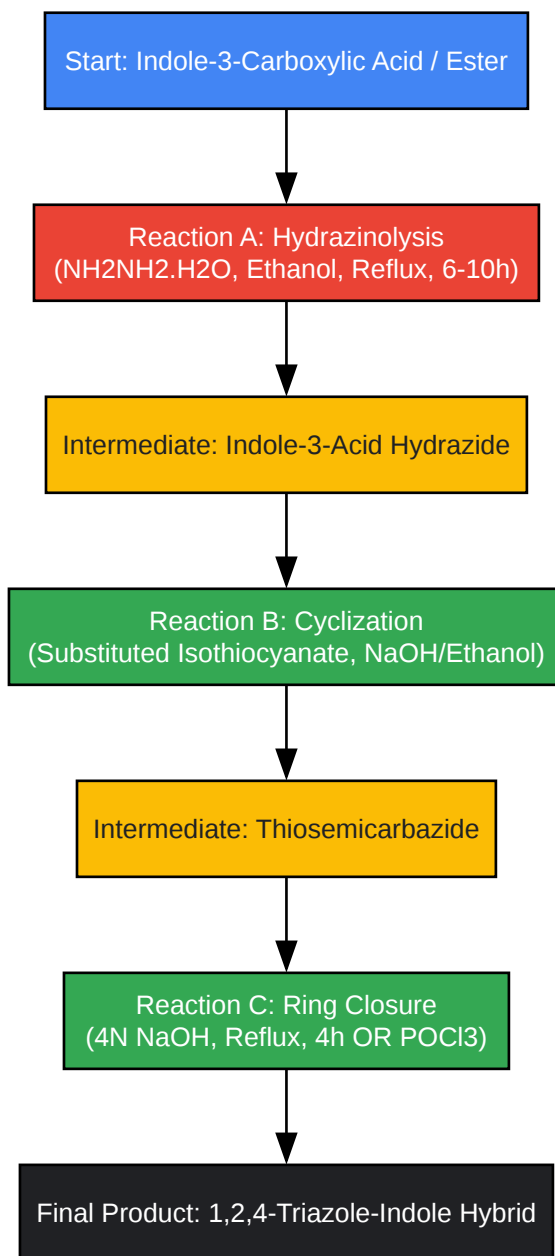

[Click to download full resolution via product page](#)

Figure 2: General synthesis pathway for 1,2,4-triazole-indole hybrids via the hydrazide route.

Protocol Validation (Self-Check):

- Step 2 Check: The formation of the hydrazone is confirmed by the disappearance of the ester C=O peak ($\sim 1720\text{ cm}^{-1}$) and appearance of hydrazone C=O ($\sim 1650\text{ cm}^{-1}$) in IR.
- Step 6 Check: Successful cyclization to the triazole ring is validated by the disappearance of the C=S (thiosemicarbazide) signals if using the basic cyclization route, or by characteristic Triazole-H signals in $^1\text{H-NMR}$ (typically near 8.5-9.0 ppm if C5 is unsubstituted).

Tubulin Polymerization Inhibition Assay

To confirm the mechanism of action for anticancer derivatives (specifically 3,4,5-trimethoxy analogs).

Reagents:

- Purified bovine brain tubulin (>99%).
- GTP (Guanosine triphosphate).
- PEM Buffer (80 mM PIPES, 1 mM EGTA, 1 mM MgCl_2 , pH 6.9).

Methodology:

- Preparation: Dilute tubulin to 3 mg/mL in PEM buffer containing 1 mM GTP.
- Incubation: Keep the tubulin solution on ice. Add the test compound (dissolved in DMSO) at varying concentrations (e.g., 1, 5, 10 μM). Include a Vehicle Control (DMSO only) and a Positive Control (Colchicine 5 μM).
- Measurement: Transfer the mixture to a pre-warmed (37°C) 96-well plate.
- Kinetics: Monitor the absorbance at 340 nm every 30 seconds for 60 minutes using a spectrophotometer.
- Analysis: Polymerization manifests as an increase in turbidity (absorbance). Calculate the V_{max} (rate of polymerization) and determine the % Inhibition relative to the vehicle control.

Interpretation:

- A "flat" line (no increase in Abs340) indicates complete inhibition of tubulin polymerization (similar to Colchicine).
- This confirms the compound acts as a destabilizing agent, preventing microtubule formation.

References

- Design, Synthesis, and Antiproliferative Activity of Novel Indole/1,2,4-Triazole Hybrids as Tubulin Polymerization Inhibitors. Source: MDPI (2025). URL:[[Link](#)]
- Synthesis, Molecular Docking, and Biological Evaluation of Novel Indole-triazole Conjugates. Source: PubMed (2024). URL:[[Link](#)]
- Discovery of new indole-based 1,2,4-triazole derivatives as potent tubulin polymerization inhibitors with anticancer activity. Source: RSC Publishing (New Journal of Chemistry, 2021). URL:[[Link](#)]
- Antimicrobial Activities of New Indole Derivatives Containing 1,2,4-Triazole. Source: Turk J Pharm Sci (2018).[3] URL:[[Link](#)]
- Synthesis of New Bioactive Indolyl-1,2,4-Triazole Hybrids As Dual Inhibitors for EGFR/PARP-1. Source: ACS Omega (2022). URL:[[Link](#)]

Need Custom Synthesis?

BenchChem offers custom synthesis for rare earth carbides and specific isotopic labeling.

Email: info@benchchem.com or [Request Quote Online](#).

Sources

- 1. scilit.com [scilit.com]
- 2. mdpi.com [mdpi.com]
- 3. Antimicrobial Activities of New Indole Derivatives Containing 1,2,4-Triazole, 1,3,4-Thiadiazole and Carbothioamide - PubMed [pubmed.ncbi.nlm.nih.gov]
- To cite this document: BenchChem. [Comparative Guide: Structure-Activity Relationship (SAR) of Indolyl-1,2,4-Triazole Derivatives]. BenchChem, [2026]. [Online PDF]. Available at:

[\[https://www.benchchem.com/product/b3047309/docs#comparative-guide-structure-activity-relationship-sar-of-indolyl-1-2-4-triazole-derivatives\]](https://www.benchchem.com/product/b3047309/docs#comparative-guide-structure-activity-relationship-sar-of-indolyl-1-2-4-triazole-derivatives)

Disclaimer & Data Validity:

The information provided in this document is for Research Use Only (RUO) and is strictly not intended for diagnostic or therapeutic procedures. While BenchChem strives to provide accurate protocols, we make no warranties, express or implied, regarding the fitness of this product for every specific experimental setup.

Technical Support: The protocols provided are for reference purposes. Unsure if this reagent suits your experiment?

Need Industrial/Bulk Grade? [Request Custom Synthesis Quote](#)

BenchChem

Our mission is to be the trusted global source of essential and advanced chemicals, empowering scientists and researchers to drive progress in science and industry.

Contact

Address: 3281 E Guasti Rd
Ontario, CA 91761, United States
Phone: (601) 213-4426
Email: info@benchchem.com

[Contact our Ph.D. Support Team for a compatibility check](#)