

Comparative Analysis: IR Spectroscopy for Structural Elucidation of Hydroxy-Biaryl Amides

Author: BenchChem Technical Support Team. **Date:** May 2026

Compound of Interest

Compound Name: *3-Hydroxy-5-phenylbenzamide*

CAS No.: 1400644-43-0

Cat. No.: B3047478

[Get Quote](#)

Content Type: Publish Comparison Guide Audience: Researchers, Medicinal Chemists, and Spectroscopists Focus: Characterization of Intramolecular Hydrogen Bonding (IMHB) in Biaryl Atropisomers

Executive Summary: The Conformational Lock

In drug discovery, hydroxy-biaryl amides represent a privileged scaffold. The interaction between the hydroxyl group on one ring and the amide carbonyl/nitrogen on the other creates a "conformational lock"—an intramolecular hydrogen bond (IMHB) that restricts rotation, influences atropisomerism, and dramatically improves membrane permeability by "hiding" polar donors.

While NMR (Nuclear Magnetic Resonance) and X-ray crystallography are standard for structural determination, they have limitations in this specific context. NMR timescales often average out rapid conformational exchanges, and X-ray requires single crystals that may not represent the solution-state pharmacophore.

This guide validates Infrared (IR) Spectroscopy as the superior rapid-screening tool for confirming the "locked" conformation. We compare its performance against alternatives and

provide a self-validating protocol for distinguishing intramolecular vs. intermolecular bonding.

Comparative Analysis: IR vs. NMR vs. XRD

The following table objectively compares the performance of IR spectroscopy against standard alternatives for characterizing hydroxy-biaryl amides.

Feature	IR Spectroscopy	¹ H NMR (Solution)	X-Ray Crystallography
Primary Detection	Bond Energy (Vibrational Frequency)	Magnetic Environment (Chemical Shift)	Electron Density (3D Coordinates)
IMHB Sensitivity	High. Direct measurement of bond weakening (Red Shift).	Medium. Downfield shift of OH/NH protons, but solvent dependent.	High. Direct visualization, but limited to solid state packing.
Time Scale	Femtosecond (s) – "Snapshots" of all conformers.	Millisecond (s) – Often observes an average of conformers.	Static (Frozen).
Sample State	Solid, Liquid, or Gas.	Liquid (Soluble only).	Solid (Single Crystal required).
Throughput	High (ATR-FTIR takes <2 mins).	Medium (Requires locking/shimming).	Low (Crystal growth can take weeks).
Differentiation	Excellent. Distinguishes Inter- vs. Intramolecular H-bonds via dilution.	Good. Requires Variable Temperature (VT) or dilution studies.	Poor. Cannot distinguish packing forces from intrinsic conformation.

“

Verdict: While XRD is the gold standard for absolute configuration, IR Spectroscopy is the most efficient technique for screening conformational locking in solution, providing immediate feedback on bond strength and permeability potential.

Characteristic Peaks: The Spectral Fingerprint

In hydroxy-biaryl amides, the formation of an IMHB causes specific frequency shifts due to the change in bond force constants.

The "Red Shift" and "Blue Shift" Mechanics

- **Stretching Vibrations (Red Shift):** Hydrogen bonding weakens the covalent bond (e.g., O-H or C=O), lengthening it. This lowers the force constant, causing the peak to shift to a lower wavenumber.
- **Bending Vibrations (Blue Shift):** Hydrogen bonding constrains the atom, making it harder to bend out of plane. This increases the energy required, causing the peak to shift to a higher wavenumber.

Diagnostic Peak Table[1]

Vibrational Mode	Functional Group	Free Frequency (cm ⁻¹)	H-Bonded Frequency (cm ⁻¹)	Shift Type	Notes
O-H Stretch	Hydroxyl (Ar-OH)	3590 – 3650 (Sharp)	3200 – 3450	Red Shift (Large)	The "Smoking Gun" for IMHB. Intra-H-bonds are sharper than Inter-H-bonds.
Amide I	Carbonyl (C=O)	1660 – 1690	1630 – 1650	Red Shift (Moderate)	Conjugation with the biaryl system also lowers this frequency; H-bonding lowers it further.
Amide II	N-H Bend / C-N Stretch	1520 – 1540	1540 – 1560	Blue Shift	The bending motion is restricted by the H-bond, requiring higher energy.
N-H Stretch	Amide (N-H)	3400 – 3500	3300 – 3350	Red Shift (Small)	Less dramatic than O-H, but useful for secondary amides.

Experimental Protocols

Protocol A: The "Self-Validating" Dilution Study

Objective: To definitively distinguish between Intermolecular H-bonding (concentration dependent, aggregation) and Intramolecular H-bonding (concentration independent, conformational lock).

Reagents:

- Analyte: Hydroxy-biaryl amide derivative.
- Solvent: Non-polar, non-H-bonding solvent (e.g., CCl₄ or dry CH₂Cl₂). Note: Chloroform (CHCl₃) can be used but may act as a weak H-bond donor.

Workflow:

- Preparation: Prepare a high-concentration stock solution (e.g., 0.1 M).
- Baseline Scan: Acquire FTIR spectrum using a liquid transmission cell (CaF₂ or KBr windows) with a path length of 0.1–1.0 mm.
- Serial Dilution: Dilute the stock to 0.01 M, 0.001 M, and 0.0001 M.
- Acquisition: Acquire spectra for each concentration. Crucial: Increase the number of scans (e.g., from 16 to 64 or 128) as concentration drops to maintain Signal-to-Noise ratio.
- Analysis: Overlay the spectra in the O-H stretching region (3200–3700 cm⁻¹).

Interpretation Criteria:

- Scenario A (Intermolecular): The broad peak at ~3300 cm⁻¹ diminishes, and a sharp peak at ~3600 cm⁻¹ (Free OH) grows as dilution increases.
- Scenario B (Intramolecular / Locked): The peak position and shape at ~3300–3400 cm⁻¹ remain unchanged regardless of dilution.

Protocol B: Solid-State ATR (Polymorph Check)

Objective: Rapid quality control of the solid form.

- Place ~2 mg of solid sample on the Diamond/ZnSe crystal of the ATR module.
- Apply pressure using the anvil until the force gauge hits the optimal zone.
- Scan from 4000 to 600 cm^{-1} .
- Checkpoint: If the Amide I peak appears split or significantly shifted compared to the solution spectrum, the solid state may be forcing a packing geometry that breaks the intramolecular H-bond.

Visualizing the Logic

Diagram 1: The Dilution Logic Tree

This diagram illustrates the decision process for interpreting the Dilution Study data, ensuring scientific integrity in assigning the H-bond type.

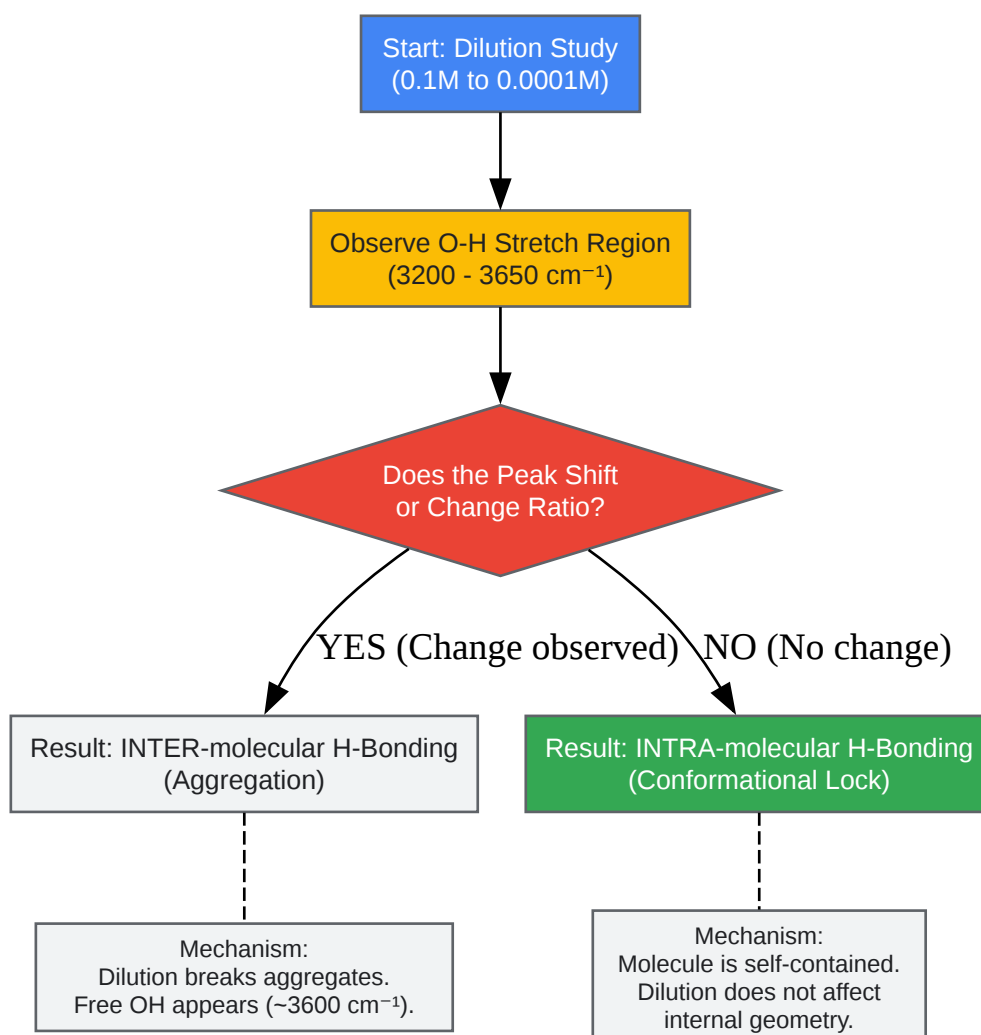

[Click to download full resolution via product page](#)

Caption: Logic flow for distinguishing Inter- vs. Intramolecular hydrogen bonding via IR dilution studies.

Diagram 2: Spectral Features of the Conformational Lock

This diagram maps the physical atomic interactions to the observed spectral shifts.

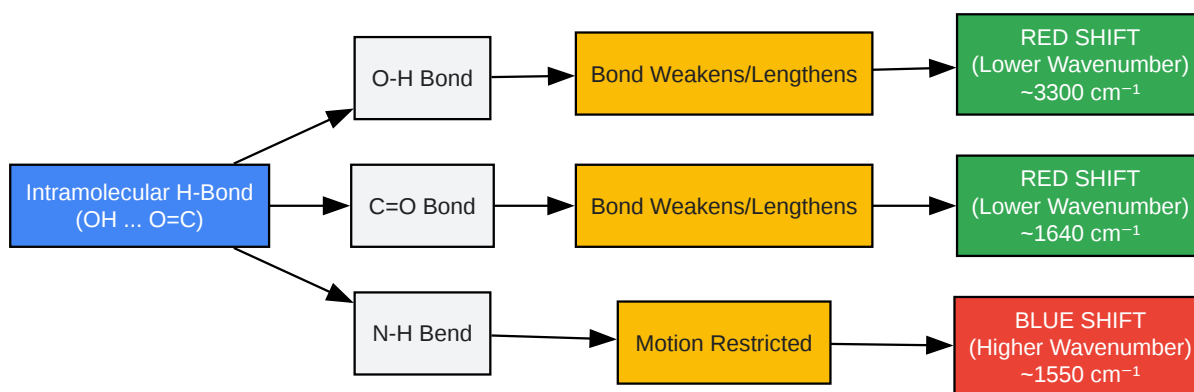

[Click to download full resolution via product page](#)

Caption: Mechanistic causality linking the intramolecular hydrogen bond to specific IR spectral shifts.

References

- Hansen, P. E., & Spanget-Larsen, J. (2017). NMR and IR Investigations of Strong Intramolecular Hydrogen Bonds.[2][3][4] *Molecules*, 22(4), 552.[5] [\[Link\]](#)
- Smith, B. C. (2020).[1] *Organic Nitrogen Compounds, VII: Amides—The Rest of the Story*.[\[1\]](#) *Spectroscopy*, 35(1), 10–15. [\[Link\]](#)
- JoVE Science Education Database. (2024). IR Spectrum Peak Broadening: Hydrogen Bonding.[6][7] *Journal of Visualized Experiments*. [\[Link\]](#)
- Palomar, J., et al. (1999).[8] Vibrational study of intramolecular hydrogen bonding in o-hydroxybenzoyl compounds. *Chemical Physics*, 246(1-3), 167-208.[8] [\[Link\]](#)

- UCLA Chemistry & Biochemistry. (n.d.). Table of IR Absorptions.[\[Link\]](#)

Need Custom Synthesis?

BenchChem offers custom synthesis for rare earth carbides and specific isotopic labeling.

Email: info@benchchem.com or [Request Quote Online](#).

Sources

- [1. spectroscopyonline.com](https://spectroscopyonline.com) [spectroscopyonline.com]
- [2. jchemrev.com](https://jchemrev.com) [jchemrev.com]
- [3. jchemrev.com](https://jchemrev.com) [jchemrev.com]
- [4. mdpi.com](https://mdpi.com) [mdpi.com]
- 5. NMR and IR Investigations of Strong Intramolecular Hydrogen Bonds - PMC [[pmc.ncbi.nlm.nih.gov](https://pubmed.ncbi.nlm.nih.gov/16411111/)]
- [6. masterorganicchemistry.com](https://masterorganicchemistry.com) [masterorganicchemistry.com]
- 7. Video: IR Spectrum Peak Broadening: Hydrogen Bonding [[jove.com](https://www.jove.com/video/54444/)]
- 8. Sci-Hub. Vibrational study of intramolecular hydrogen bonding in o-hydroxybenzoyl compounds / Chemical Physics, 1999 [[sci-hub.jp](https://sci-hub.jp/10.1016/S0301-0104(99)00001-1)]
- To cite this document: BenchChem. [Comparative Analysis: IR Spectroscopy for Structural Elucidation of Hydroxy-Biaryl Amides]. BenchChem, [2026]. [Online PDF]. Available at: [<https://www.benchchem.com/product/b3047478/docs#comparative-analysis-ir-spectroscopy-for-structural-elucidation-of-hydroxy-biaryl-amides>]

Disclaimer & Data Validity:

The information provided in this document is for Research Use Only (RUO) and is strictly not intended for diagnostic or therapeutic procedures. While BenchChem strives to provide accurate protocols, we make no warranties, express or implied, regarding the fitness of this product for every specific experimental setup.

Technical Support: The protocols provided are for reference purposes. Unsure if this reagent suits your experiment?

Need Industrial/Bulk Grade? [Request Custom Synthesis Quote](#)

BenchChem

Our mission is to be the trusted global source of essential and advanced chemicals, empowering scientists and researchers to drive progress in science and industry.

Contact

Address: 3281 E Guasti Rd
Ontario, CA 91761, United States
Phone: (601) 213-4426
Email: info@benchchem.com

[Contact our Ph.D. Support Team for a compatibility check](#)