

Application Notes and Protocols: The Use of Methyltetrazine in Activity-Based Protein Profiling

Author: BenchChem Technical Support Team. **Date:** April 2026

Compound of Interest

Compound Name:	4-(6-Methyl-1,2,4,5-tetrazin-3-yl)benzoic acid
CAS No.:	1345866-66-1
Cat. No.:	B3047056

[Get Quote](#)

Introduction: A New Era in Functional Proteomics

Activity-based protein profiling (ABPP) has emerged as a powerful chemoproteomic strategy to study the functional state of enzymes in complex biological systems.^{[1][2][3][4]} Unlike traditional proteomic approaches that measure protein abundance, ABPP utilizes chemical probes that covalently bind to the active site of enzymes, providing a direct readout of their catalytic activity.^{[5][6][7]} This distinction is critical, as many enzymes are regulated at the level of their activity rather than their expression levels.^{[5][8][9]} The integration of bioorthogonal chemistry into ABPP workflows has further revolutionized the field, allowing for the two-step labeling of active enzymes with minimal perturbation of their biological function.^{[1][3][5][10]} Among the arsenal of bioorthogonal reactions, the inverse-electron-demand Diels-Alder (IEDDA) cycloaddition between methyltetrazine and a strained alkene, such as trans-cyclooctene (TCO), has gained prominence due to its exceptionally fast reaction kinetics and high specificity in biological environments.^{[11][12][13]}

This technical guide provides an in-depth exploration of the application of methyltetrazine in ABPP, offering detailed protocols and expert insights for researchers, scientists, and drug development professionals. We will delve into the underlying chemical principles, the design of methyltetrazine-containing activity-based probes (ABPs), and step-by-step methodologies for labeling and identifying active enzymes in complex proteomes.

The Chemistry of Precision: Methyltetrazine-TCO Ligation

The cornerstone of this methodology is the IEDDA reaction, a [4+2] cycloaddition where the electron-poor tetrazine (the diene) rapidly and specifically reacts with an electron-rich and strained dienophile, most commonly a trans-cyclooctene (TCO).^{[11][12][13]} This reaction is characterized by its remarkable speed, with second-order rate constants reaching up to $10^6 \text{ M}^{-1}\text{s}^{-1}$, and its ability to proceed in complex biological milieu without the need for cytotoxic catalysts like copper.^{[11][13][14][15]} The only byproduct of this ligation is nitrogen gas, rendering the reaction irreversible and highly efficient.^{[11][13]}

The workflow for methyltetrazine-based ABPP typically involves two key steps:

- **Enzyme Labeling:** An activity-based probe (ABP) containing a methyltetrazine moiety is introduced to the biological sample (e.g., cell lysate, live cells). The ABP consists of three key components: a reactive group that covalently modifies the active site of the target enzyme, a recognition element that directs the probe to a specific enzyme or enzyme family, and the methyltetrazine handle for subsequent ligation.^[4]
- **Bioorthogonal Ligation:** A reporter tag functionalized with a TCO group (e.g., a fluorophore or biotin) is added. The TCO rapidly and specifically reacts with the methyltetrazine on the ABP-enzyme conjugate, allowing for visualization or enrichment of the active enzymes.^{[5][11]}

This two-step approach offers significant advantages over traditional one-step ABPP, where the reporter tag is pre-attached to the probe. Large reporter groups can sterically hinder the probe's interaction with the target enzyme, affecting its specificity and cell permeability.^{[5][9]} By using a small, minimally-perturbing methyltetrazine handle, these issues are largely circumvented.^{[5][8][10]}

Visualizing the Workflow: Methyltetrazine-Based ABPP

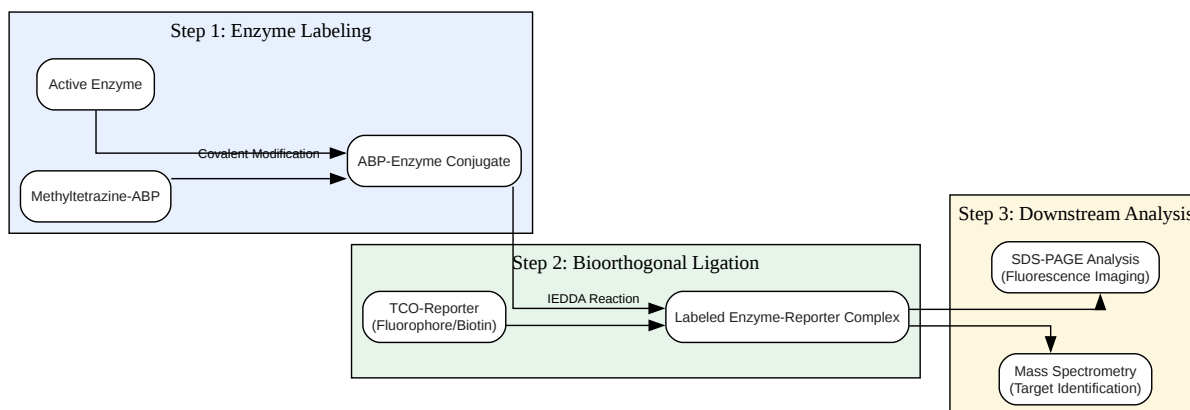

[Click to download full resolution via product page](#)

Caption: A generalized workflow for methyltetrazine-based activity-based protein profiling.

Quantitative Data Summary: Reaction Kinetics

The choice of bioorthogonal chemistry is often dictated by its kinetic properties. The following table summarizes the second-order rate constants for the methyltetrazine-TCO ligation in comparison to other common bioorthogonal reactions.

Bioorthogonal Reaction	Dienophile/Alkyne	Diene/Azide	Second-Order Rate Constant (k_2) ($M^{-1}s^{-1}$)	Reference
IEDDA	trans-cyclooctene (TCO)	Methyltetrazine	up to 1×10^6	[11][13]
Strain-Promoted Azide-Alkyne Cycloaddition (SPAAC)	Dibenzocyclooctyne (DBCO)	Azide	~ 1	[15]
Copper(I)-Catalyzed Azide-Alkyne Cycloaddition (CuAAC)	Terminal Alkyne	Azide	$10^2 - 10^3$	[1]

Experimental Protocols

Protocol 1: General Procedure for In-Gel Fluorescence Profiling of Enzyme Activity in Cell Lysates

This protocol outlines a general method for profiling the activity of a target enzyme class in a cell lysate using a methyltetrazine-functionalized ABP and a TCO-fluorophore.

Materials:

- Cells of interest
- Lysis buffer (e.g., PBS with 0.1% Triton X-100, protease inhibitors optional)
- Methyltetrazine-functionalized Activity-Based Probe (ABP) stock solution (in DMSO)
- TCO-functionalized fluorophore (e.g., TCO-Cy5) stock solution (in DMSO)
- 4x SDS-PAGE loading buffer

- Bradford assay reagent or equivalent for protein quantification
- Fluorescence gel scanner

Procedure:

- Cell Lysis:
 - Harvest cells and wash with cold PBS.
 - Resuspend the cell pellet in lysis buffer and incubate on ice for 30 minutes.
 - Clarify the lysate by centrifugation at 14,000 x g for 15 minutes at 4°C.
 - Collect the supernatant and determine the protein concentration.
- ABP Labeling:
 - Dilute the cell lysate to a final concentration of 1 mg/mL in lysis buffer.
 - Add the methyltetrazine-ABP to the lysate at a final concentration of 1 μ M (this may need to be optimized for your specific probe and target).
 - Incubate for 30-60 minutes at room temperature.
- TCO-Fluorophore Ligation:
 - Add the TCO-fluorophore to the labeled lysate at a final concentration of 10-50 μ M.
 - Incubate for 30-60 minutes at room temperature in the dark. The disappearance of the characteristic pink color of the tetrazine can sometimes be used to monitor the reaction's progress.[\[11\]](#)
- SDS-PAGE Analysis:
 - Quench the reaction by adding 4x SDS-PAGE loading buffer.
 - Boil the samples at 95°C for 5 minutes.

- Resolve the proteins on an SDS-PAGE gel.
- Visualize the fluorescently labeled proteins using a fluorescence gel scanner at the appropriate excitation and emission wavelengths for your chosen fluorophore.

Protocol 2: Pull-down and Identification of Target Enzymes

This protocol describes the enrichment of ABP-labeled enzymes for subsequent identification by mass spectrometry.

Materials:

- Cell lysate labeled with methyltetrazine-ABP (from Protocol 1, Step 2)
- TCO-functionalized biotin (e.g., TCO-PEG-Biotin) stock solution (in DMSO)
- Streptavidin-agarose beads
- Wash buffer (e.g., PBS with 0.5% SDS)
- Elution buffer (e.g., 2x SDS-PAGE loading buffer)
- Mass spectrometry-compatible reagents for in-gel or on-bead digestion

Procedure:

- Biotin Ligation:
 - To the methyltetrazine-ABP labeled lysate, add TCO-biotin to a final concentration of 25-100 μM .
 - Incubate for 1 hour at room temperature.
- Enrichment of Biotinylated Proteins:
 - Add pre-washed streptavidin-agarose beads to the lysate and incubate for 1-2 hours at 4°C with gentle rotation.

- Pellet the beads by centrifugation and discard the supernatant.
- Wash the beads extensively with wash buffer (e.g., 3-5 times) to remove non-specifically bound proteins.
- Elution and Sample Preparation for Mass Spectrometry:
 - Elute the bound proteins by resuspending the beads in 2x SDS-PAGE loading buffer and boiling for 5-10 minutes.
 - Alternatively, for on-bead digestion, proceed with reduction, alkylation, and tryptic digestion of the bead-bound proteins according to established mass spectrometry protocols.
 - Analyze the eluted proteins or digested peptides by LC-MS/MS for protein identification.

Visualizing the Chemical Transformation

Caption: The inverse-electron-demand Diels-Alder (IEDDA) reaction between methyltetrazine and trans-cyclooctene (TCO).

Causality Behind Experimental Choices and Self-Validating Systems

The protocols provided are designed to be robust and self-validating. Here, we explain the rationale behind key experimental choices:

- **Probe and Reporter Concentrations:** The concentration of the methyltetrazine-ABP should be carefully optimized to ensure specific labeling of the target enzyme(s) without causing off-target effects. A 10 to 50-fold excess of the TCO-reporter is often used to drive the ligation reaction to completion.
- **Reaction Times:** The incubation times for both the ABP labeling and the TCO ligation are dependent on the specific probe, target enzyme, and reporter used. The rapid kinetics of the IEDDA reaction typically allow for shorter incubation times compared to other bioorthogonal ligations.

- Controls: To ensure the specificity of the labeling, several controls are essential:
 - No-probe control: A sample treated with DMSO instead of the methyltetrazine-ABP to identify non-specific binding of the TCO-reporter.
 - Heat-inactivated lysate: A sample where the lysate is boiled prior to ABP addition to demonstrate that labeling is dependent on active enzymes.
 - Competitive inhibition: Pre-incubation of the lysate with a known inhibitor of the target enzyme class should reduce or abolish the labeling by the ABP.

By incorporating these controls, researchers can have high confidence in the specificity and validity of their results.

Future Directions and Conclusion

The use of methyltetrazine in activity-based protein profiling is a rapidly evolving field.^[16] The development of new methyltetrazine-containing unnatural amino acids allows for the site-specific incorporation of this bioorthogonal handle into proteins through genetic code expansion, opening up new avenues for studying protein function.^{[13][17][18]} Furthermore, the exceptional kinetics of the methyltetrazine-TCO ligation are being leveraged for in vivo imaging applications, enabling the visualization of enzyme activity in living organisms.^[12]

In conclusion, the methyltetrazine-TCO ligation offers a powerful and versatile tool for activity-based protein profiling. Its rapid kinetics, high specificity, and biocompatibility make it an ideal choice for a wide range of applications, from in-gel fluorescence scanning to in vivo imaging. The protocols and insights provided in this guide are intended to empower researchers to harness the full potential of this cutting-edge technology in their scientific endeavors.

References

- Methyltetrazine as a small live-cell compatible bioorthogonal handle for imaging enzyme activities in situ. RSC Publishing. [\[Link\]](#)
- Bioorthogonal Reactions in Activity-Based Protein Profiling. MDPI. [\[Link\]](#)

- Methyltetrazine as a small live-cell compatible bioorthogonal handle for imaging enzyme activities in situ. RSC Publishing. [\[Link\]](#)
- Bioorthogonal Chemistry: Applications in Activity-Based Protein Profiling. ACS Publications. [\[Link\]](#)
- Bioorthogonal Reactions in Activity-Based Protein Profiling. PubMed. [\[Link\]](#)
- Methyltetrazine as a small live-cell compatible bioorthogonal handle for imaging enzyme activities in situ. ResearchGate. [\[Link\]](#)
- Bioorthogonal Reactions in Activity-Based Protein Profiling. ResearchGate. [\[Link\]](#)
- Bioorthogonal chemistry: applications in activity-based protein profiling. PubMed. [\[Link\]](#)
- Tetrazine Amino Acid Encoding for Rapid and Complete Protein Bioconjugation. Bio-protocol. [\[Link\]](#)
- Site-Specific Protein Labeling with Tetrazine Amino Acids. Springer Nature Experiments. [\[Link\]](#)
- Methyltetrazine as a small live-cell compatible bioorthogonal handle for imaging enzyme activities in situ. PMC. [\[Link\]](#)
- Site-specific bioorthogonal protein labelling by tetrazine ligation using endogenous β -amino acid dienophiles. PMC. [\[Link\]](#)
- Investigation of Proteome-Tetrazine Reactivity for a Highly Selective Tetrazine Ligation in Live Cells. PMC. [\[Link\]](#)
- Tetrazine ligation for chemical proteomics. PMC. [\[Link\]](#)
- An Overview of Methyltetrazine Amine. Medium. [\[Link\]](#)
- Detection of protein-protein interactions by bio-orthogonal fluorogenic proximity probes. bioRxiv. [\[Link\]](#)
- Bioorthogonal Reactions in Activity-Based Protein Profiling. PMC. [\[Link\]](#)

- An overview of activity-based protein profiling and recent advances. Imperial News. [[Link](#)]

Need Custom Synthesis?

BenchChem offers custom synthesis for rare earth carbides and specific isotopic labeling.

Email: info@benchchem.com or [Request Quote Online](#).

Sources

- 1. mdpi.com [mdpi.com]
- 2. pubs.acs.org [pubs.acs.org]
- 3. Bioorthogonal Reactions in Activity-Based Protein Profiling - PubMed [pubmed.ncbi.nlm.nih.gov]
- 4. researchgate.net [researchgate.net]
- 5. pubs.rsc.org [pubs.rsc.org]
- 6. Bioorthogonal Reactions in Activity-Based Protein Profiling - PMC [pmc.ncbi.nlm.nih.gov]
- 7. An overview of activity-based protein profiling and recent advances | Imperial News | Imperial College London [imperial.ac.uk]
- 8. researchgate.net [researchgate.net]
- 9. Methyltetrazine as a small live-cell compatible bioorthogonal handle for imaging enzyme activities in situ - PMC [pmc.ncbi.nlm.nih.gov]
- 10. Methyltetrazine as a small live-cell compatible bioorthogonal handle for imaging enzyme activities in situ - RSC Chemical Biology (RSC Publishing) [pubs.rsc.org]
- 11. pdf.benchchem.com [pdf.benchchem.com]
- 12. pdf.benchchem.com [pdf.benchchem.com]
- 13. Tetrazine ligation for chemical proteomics - PMC [pmc.ncbi.nlm.nih.gov]
- 14. Investigation of Proteome-Tetrazine Reactivity for a Highly Selective Tetrazine Ligation in Live Cells - PMC [pmc.ncbi.nlm.nih.gov]
- 15. benchchem.com [benchchem.com]
- 16. Bioorthogonal chemistry: applications in activity-based protein profiling - PubMed [pubmed.ncbi.nlm.nih.gov]
- 17. bio-protocol.org [bio-protocol.org]

- [18. Site-Specific Protein Labeling with Tetrazine Amino Acids | Springer Nature Experiments \[experiments.springernature.com\]](#)
- To cite this document: BenchChem. [Application Notes and Protocols: The Use of Methyltetrazine in Activity-Based Protein Profiling]. BenchChem, [2026]. [Online PDF]. Available at: [<https://www.benchchem.com/product/b3047056/docs#application-notes-and-protocols-the-use-of-methyltetrazine-in-activity-based-protein-profiling>]

Disclaimer & Data Validity:

The information provided in this document is for Research Use Only (RUO) and is strictly not intended for diagnostic or therapeutic procedures. While BenchChem strives to provide accurate protocols, we make no warranties, express or implied, regarding the fitness of this product for every specific experimental setup.

Technical Support: The protocols provided are for reference purposes. Unsure if this reagent suits your experiment?

Need Industrial/Bulk Grade? [Request Custom Synthesis Quote](#)

BenchChem

Our mission is to be the trusted global source of essential and advanced chemicals, empowering scientists and researchers to drive progress in science and industry.

Contact

Address: 3281 E Guasti Rd
Ontario, CA 91761, United States
Phone: (601) 213-4426
Email: info@benchchem.com

[Contact our Ph.D. Support Team for a compatibility check](#)