

Comparative Guide: UV-Vis-NIR Spectroscopy of Doped Poly(3-ethoxythiophene) (PEOT)

Author: BenchChem Technical Support Team. **Date:** April 2026

Compound of Interest

Compound Name: 3-Ethoxythiophene

CAS No.: 114292-37-4

Cat. No.: B3045810

[Get Quote](#)

Executive Summary

Poly(3-ethoxythiophene) (PEOT) represents a critical intermediate class of conjugated polymers, bridging the gap between alkyl-substituted standards like P3HT and the highly conductive, bridged-alkoxy standard PEDOT. For researchers in organic electronics and drug delivery, PEOT offers a unique structure-property relationship: the ethoxy side chain provides strong electron-donating capabilities via the mesomeric effect, yet introduces specific steric interactions that govern backbone planarity.

This guide objectively compares the UV-Vis-NIR spectral evolution of PEOT upon doping against its primary alternatives. It details the transition from neutral excitonic absorption to polaron and bipolaron charge-carrier bands, providing a validated spectroelectrochemical protocol for characterizing these states.

Technical Analysis: The Alkoxy Advantage & Steric Challenge

To interpret the spectroscopy of PEOT, one must understand the competing electronic and steric forces introduced by the ethoxy substituent.

Electronic Effects (Mesomeric vs. Inductive)

Unlike P3HT (Poly(3-hexylthiophene)), where the alkyl chain donates electrons weakly via the inductive (

) effect, the oxygen atom in PEOT donates electrons directly into the thiophene ring's

-system via the mesomeric (

) effect.

- Result: This raises the Highest Occupied Molecular Orbital (HOMO) energy, lowering the ionization potential.
- Spectroscopic Implication: PEOT typically exhibits a lower optical bandgap () than P3HT, leading to a red-shifted neutral absorption peak, provided the backbone remains planar.

Steric Effects (Regioregularity is Critical)

The performance of PEOT is heavily dependent on regioregularity.

- Head-to-Head (HH) Coupling: The ethoxy oxygen atoms create significant steric repulsion, twisting the backbone and breaking conjugation. This results in a blue-shift (higher bandgap) and poor conductivity.
- Head-to-Tail (HT) Coupling: Minimizes steric clash, allowing the mesomeric effect to dominate. This guide assumes Regioregular (HT) PEOT as the standard for comparison.

Comparative Performance: PEOT vs. P3HT vs. PEDOT

The following table synthesizes experimental data comparing PEOT with the industry standards.

Table 1: Spectroscopic & Electronic Property Comparison

Feature	P3HT (Alkyl Reference)	PEOT (Target Material)	PEDOT (High-Performance Ref)
Side Chain Type	Alkyl (Hexyl)	Alkoxy (Ethoxy)	Di-alkoxy (Ethylenedioxy bridge)
Electronic Effect	Inductive ()	Mesomeric ()	Strong Mesomeric () + Planarization
Bandgap ()	~1.9 eV	~1.75 eV (Regioregular)	~1.6 eV
Neutral	500–550 nm (Orange/Red)	550–590 nm (Purple/Blue)	~600 nm (Dark Blue)
Polaron Band (NIR)	~800 nm	~850–950 nm	~900 nm
Bipolaron Band (IR)	>2000 nm	>1600 nm	>1200 nm (Free carrier tail)
Oxidation Onset	~0.6 V vs SCE	~0.4 V vs SCE	~ -0.2 V vs SCE
Doped State	Opaque/Dark	Transmissive Grey/Blue	Highly Transparent (Light Blue)

“

Analyst Insight: PEOT offers a lower oxidation potential than P3HT, making it easier to dope chemically (e.g., with iodine or

). However, it lacks the extreme stability and transparency of PEDOT, which benefits from the "bridged" side chain that locks the thiophene ring in a planar conformation.

Doping Mechanism & Spectral Evolution[1]

Understanding the doping pathway is essential for interpreting UV-Vis-NIR data. As PEOT is oxidized (p-doped), the neutral

transition bleaches and new sub-gap transitions appear.

The Polaron-Bipolaron Transition

- Neutral State: Strong absorption in the visible ().
- Polaron (Radical Cation): Removal of one electron creates two new states in the bandgap.
 - Transition P1: Valence Band
Lower Polaron Level (NIR, ~1600+ nm).
 - Transition P2: Valence Band
Upper Polaron Level (Vis/NIR, ~850 nm).
- Bipolaron (Dication): Removal of a second electron (heavy doping).
 - The polaron bands coalesce into a single, broad, low-energy transition (BP1) extending deep into the NIR/IR.

Visualization: Electronic State Evolution

The following diagram illustrates the energy level shifts during the doping process.

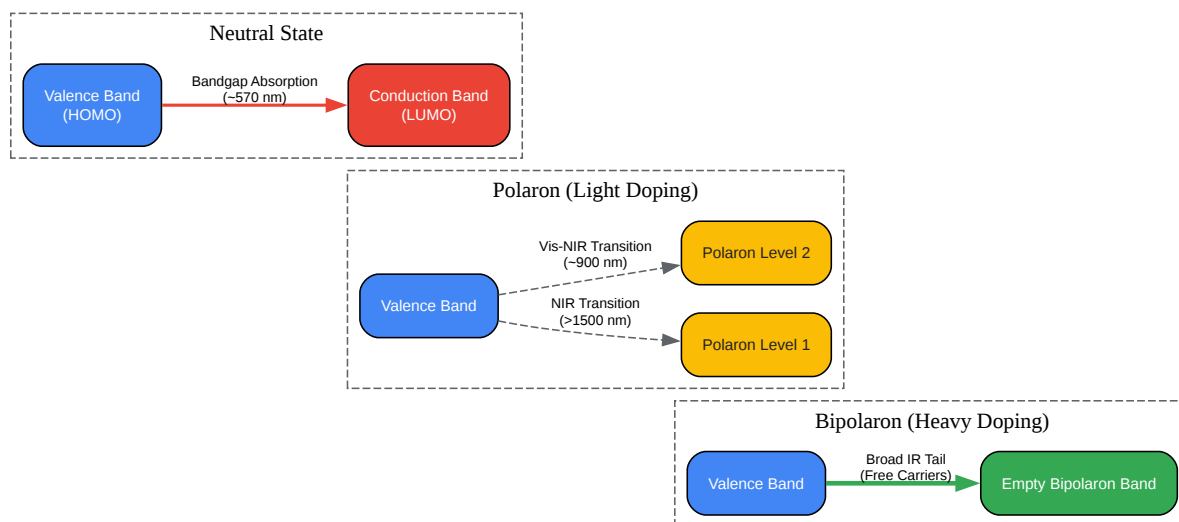

[Click to download full resolution via product page](#)

Caption: Energy level diagram showing the emergence of sub-gap states (Polaron/Bipolaron) in PEOT upon oxidation, shifting absorption from Visible to NIR.

Validated Experimental Protocol: In-Situ Spectroelectrochemistry

To obtain reliable data, In-Situ Spectroelectrochemistry is the gold standard. This method allows you to precisely control the doping level (via applied potential) while simultaneously recording the spectrum.

Materials & Equipment

- Potentiostat: (e.g., Autolab, BioLogic)
- Spectrophotometer: UV-Vis-NIR (300 nm – 2500 nm range).

- Electrochemical Cell: Quartz cuvette with a custom lid.
- Working Electrode (WE): ITO-coated glass (Indium Tin Oxide).[1]
- Counter Electrode (CE): Platinum wire/mesh.
- Reference Electrode (RE): Ag/Ag⁺ (non-aqueous) or Ag/AgCl (aqueous).
- Electrolyte: 0.1 M Tetrabutylammonium Hexafluorophosphate () in Acetonitrile (ACN).

Step-by-Step Workflow

- Film Deposition:
 - Dissolve Regioregular PEOT in Chloroform (5 mg/mL).
 - Spin-coat onto cleaned ITO glass at 1500 rpm for 60s.
 - Critical Step: Anneal at 100°C for 10 min to enhance crystallinity (improves polaron delocalization).
- Cell Assembly:
 - Place the ITO/PEOT film (WE) into the quartz cuvette.
 - Insert Pt wire (CE) and Reference Electrode (RE).[2] Ensure the CE does not block the optical path.
 - Fill with electrolyte solution.[2][3]
- Measurement Loop:
 - Step A (Neutral): Apply -0.5 V (to ensure full reduction). Record Spectrum.[2][4][5]
 - Step B (Stepwise Doping): Increase potential in +0.1 V increments (e.g., 0.0 V, +0.1 V, ... +1.0 V).[2]

- Step C (Equilibration): Hold potential for 30s at each step to allow ion diffusion before triggering the spectral scan.

Visualization: Experimental Setup

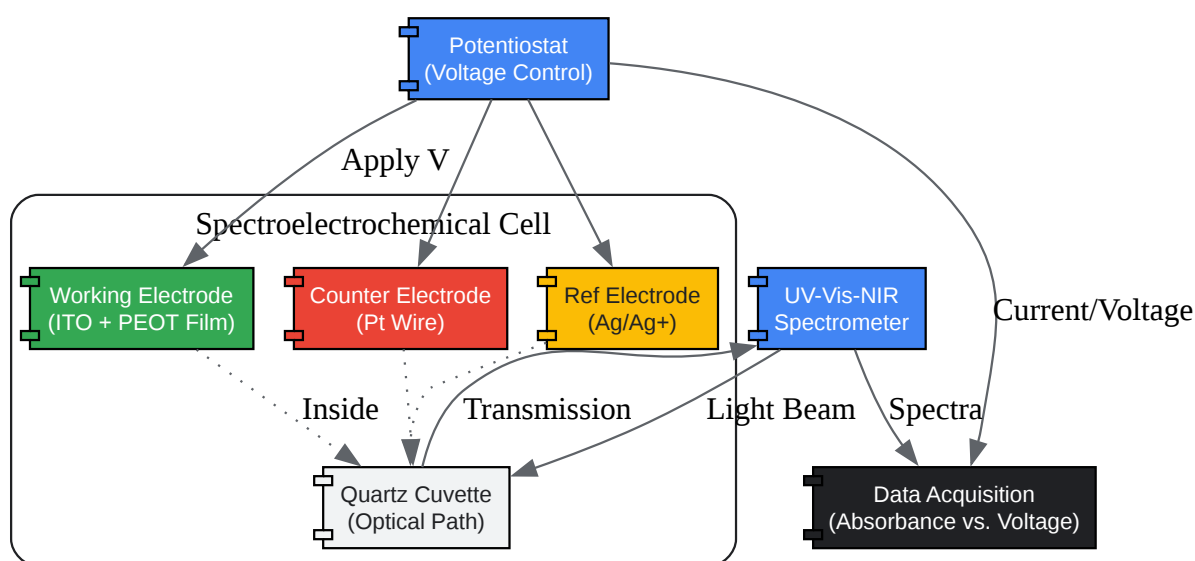

[Click to download full resolution via product page](#)

Caption: Schematic of the in-situ spectroelectrochemical setup for correlating applied potential with optical absorption changes.

References

- Leclerc, M., & Daoust, G. (1991). Structural effects in alkyl and alkoxy-substituted polythiophenes. *Synthetic Metals*. [Link](#)
- BenchChem. (2025). A Comparative Guide to the Electronic Properties of Alkylthio- vs. Alkyl-Substituted Polythiophenes. [Link](#)
- Zozoulenko, I., et al. (2021). UV-to-IR Absorption of Molecularly p-Doped Polythiophenes with Alkyl and Oligoether Side Chains: Experiment and Interpretation Based on Density Functional Theory. *Journal of Physical Chemistry C*. [Link](#)

- Reynolds, J. R., et al. (1989). Soluble ethylmercapto-substituted polythiophenes. *Macromolecules*. [Link](#)
- Groenendaal, L., et al. (2000). Poly(3,4-ethylenedioxythiophene) and Its Derivatives: Past, Present, and Future. *Advanced Materials*. (Comparison reference for PEDOT properties).

Need Custom Synthesis?

BenchChem offers custom synthesis for rare earth carbides and specific isotopic labeling.

Email: info@benchchem.com or [Request Quote Online](#).

Sources

- [1. Effect of Applied Voltage on the Electrochemical Copolymerization of Thiophene and Dithenopyrrole Derivatives | VNUHCM Journal of Science and Technology Development \[stdj.scienceandtechnology.com.vn\]](#)
- [2. openriver.winona.edu \[openriver.winona.edu\]](#)
- [3. research.unl.pt \[research.unl.pt\]](#)
- [4. arxiv.org \[arxiv.org\]](#)
- [5. faculty.uobasrah.edu.iq \[faculty.uobasrah.edu.iq\]](#)
- To cite this document: BenchChem. [Comparative Guide: UV-Vis-NIR Spectroscopy of Doped Poly(3-ethoxythiophene) (PEOT)]. BenchChem, [2026]. [Online PDF]. Available at: [\[https://www.benchchem.com/product/b3045810/docs#comparative-guide-uv-vis-nir-spectroscopy-of-doped-poly-3-ethoxythiophene-peot\]](https://www.benchchem.com/product/b3045810/docs#comparative-guide-uv-vis-nir-spectroscopy-of-doped-poly-3-ethoxythiophene-peot)

Disclaimer & Data Validity:

The information provided in this document is for Research Use Only (RUO) and is strictly not intended for diagnostic or therapeutic procedures. While BenchChem strives to provide accurate protocols, we make no warranties, express or implied, regarding the fitness of this product for every specific experimental setup.

Technical Support: The protocols provided are for reference purposes. Unsure if this reagent suits your experiment?

Need Industrial/Bulk Grade? [Request Custom Synthesis Quote](#)

BenchChem

Our mission is to be the trusted global source of essential and advanced chemicals, empowering scientists and researchers to drive progress in science and industry.

Contact

Address: 3281 E Guasti Rd
Ontario, CA 91761, United States
Phone: (601) 213-4426
Email: info@benchchem.com

[Contact our Ph.D. Support Team for a compatibility check](#)