

Stability of Bromoethane-2-D1 under experimental conditions.

Author: BenchChem Technical Support Team. **Date:** April 2026

Compound of Interest

Compound Name: Bromoethane-2-D1

CAS No.: 23705-67-1

Cat. No.: B3044131

[Get Quote](#)

Technical Support Center: Bromoethane-2-D1

Welcome to the Technical Support Center for **Bromoethane-2-D1** ($\text{CH}_2\text{DCH}_2\text{Br}$). This guide is designed for researchers, scientists, and drug development professionals to ensure the stability and successful application of this isotopically labeled compound in your experiments. Here, we address common questions and provide in-depth troubleshooting for issues you may encounter.

Part 1: Frequently Asked Questions (FAQs)

This section covers fundamental questions regarding the handling, storage, properties, and reactivity of **Bromoethane-2-D1**.

Q1: What is Bromoethane-2-D1 and what are its primary applications?

Bromoethane-2-D1 (CAS No. 23705-67-1) is the deuterated analog of bromoethane where one hydrogen atom on the methyl group (C2) has been replaced with deuterium (D).^{[1][2]} This

specific labeling makes it a valuable tool in several research areas:

- **Mechanistic Studies:** It is frequently used to probe reaction mechanisms, particularly to differentiate between competing pathways like substitution (SN2) and elimination (E2). The difference in bond strength between C-D and C-H bonds can lead to observable differences in reaction rates, a phenomenon known as the Kinetic Isotope Effect (KIE).[3][4]
- **Tracer Studies:** In metabolic or environmental fate studies, the deuterium label allows the molecule and its metabolites or degradation products to be tracked and identified, often using mass spectrometry.[5]
- **Synthesis of Labeled Compounds:** It serves as a building block for synthesizing more complex molecules containing a deuterium label at a specific position, which is crucial for quantitative analysis using isotopic dilution methods or for modifying the metabolic profile of drug candidates.[6]

Q2: What are the recommended storage and handling conditions for Bromoethane-2-D1?

Proper storage is critical to maintain the chemical and isotopic purity of **Bromoethane-2-D1**. It is a flammable and toxic liquid that requires careful handling.[1][7]

Parameter	Recommendation	Rationale
Temperature	Store refrigerated (+2°C to +8°C).[1][8]	Reduces volatility and slows potential degradation reactions.
Light	Protect from light.[5][8]	Minimizes the risk of photochemically induced degradation, such as the formation of radicals.
Atmosphere	Store in a tightly sealed container under an inert atmosphere (e.g., Argon or Nitrogen).[6][9]	Prevents contamination from atmospheric moisture and oxygen.
Ventilation	Handle in a well-ventilated area or a chemical fume hood.[7][10]	Bromoethane is harmful if inhaled and has a low boiling point (37-40 °C).[2]
Safety	Use appropriate Personal Protective Equipment (PPE), including gloves, safety goggles, and a lab coat.[10]	Avoids direct contact with the skin and eyes.[7]

Q3: How long can I expect Bromoethane-2-D1 to be stable?

When stored under the recommended conditions, **Bromoethane-2-D1** is generally a stable compound.[1] Chemical suppliers often suggest that the compound should be re-analyzed for chemical purity after three years to ensure it still meets specifications for use.[1] However, stability is highly dependent on storage conditions and the absence of contaminants.

Q4: What are the primary chemical degradation pathways for Bromoethane-2-D1?

As a primary alkyl halide, **Bromoethane-2-D1** is susceptible to two main competing reaction pathways:

- Bimolecular Nucleophilic Substitution (SN2): The compound can react with nucleophiles (Nu⁻), where the nucleophile attacks the electrophilic carbon bonded to bromine, displacing the bromide ion. This results in the formation of a new C-Nu bond.[11]
- Bimolecular Elimination (E2): In the presence of a strong base (B:⁻), a proton or deuteron can be abstracted from the C2 position, leading to the formation of ethene, the base-proton conjugate (B-H or B-D), and the bromide ion.[4][12]

The reaction conditions—particularly the nature of the base/nucleophile, solvent, and temperature—determine which pathway is dominant.

Q5: How does the deuterium label affect the reactivity of Bromoethane-2-D1 compared to unlabeled bromoethane?

The presence of deuterium at the C2 position can significantly influence the rate of certain reactions due to the Kinetic Isotope Effect (KIE).[3] The C-D bond is fundamentally stronger and vibrates at a lower frequency than a C-H bond.[4][13]

- In E2 Reactions: The rate-determining step of the E2 mechanism involves the breaking of a C-H (or C-D) bond at the beta-position (C2).[4] Because the C-D bond is stronger, it is more difficult to break. Consequently, an E2 reaction where the deuterium atom is removed will proceed slower than the corresponding reaction where a hydrogen atom is removed. This is known as a primary KIE and can result in reaction rates that are several times slower for the deuterated compound.[4]
- In SN2 Reactions: The C-D bond is not broken in an SN2 reaction. Therefore, the effect of the deuterium label on the reaction rate is much smaller (a secondary KIE) and can be difficult to observe without precise kinetic measurements.[3][13]

This difference in reactivity is a powerful tool for confirming whether a reaction proceeds via an elimination or substitution pathway.

Part 2: Troubleshooting Guide

This section addresses specific experimental issues in a question-and-answer format, providing explanations and actionable protocols.

Q1: My reaction is significantly slower or gives a lower yield than expected when using Bromoethane-2-D1 instead of standard bromoethane. What's happening?

Possible Cause: You are likely observing a primary Kinetic Isotope Effect (KIE), which strongly suggests your reaction is proceeding, at least in part, through an E2 elimination mechanism. The base in your reaction is removing the deuteron from the C2 position, and this step is slower because the C-D bond is stronger than a C-H bond.[4]

Troubleshooting Steps:

- **Analyze Your Reaction Conditions:** The E2 pathway is favored over the SN2 pathway under specific conditions. Review your protocol against the factors in the table below.

Factor	Favors SN2 Pathway	Favors E2 Pathway
Base/Nucleophile	Weak, non-bulky bases (e.g., I ⁻ , CN ⁻ , H ₂ O)[11]	Strong, sterically hindered bases (e.g., t-BuOK, LDA, OH ⁻ in ethanol)[12]
Temperature	Lower temperatures[12]	Higher temperatures[12]
Solvent	Polar aprotic (e.g., DMSO, Acetone)	Less polar or protic (e.g., Ethanol)

- **Confirm the Reaction Pathway:** To confirm that E2 elimination is the cause of the sluggish reaction, you can analyze your product mixture for the presence of ethene gas or its subsequent reaction products.
- **Optimize for Your Desired Pathway:**
 - **If you desire SN2 (Substitution):** Modify your conditions to favor substitution. Consider using a less-hindered nucleophile, switching to a polar aprotic solvent like acetone, and running the reaction at a lower temperature.

- If you desire E2 (Elimination): You must account for the slower reaction rate. Increase the reaction time, use a slightly higher temperature, or use a stronger base to drive the reaction to completion.

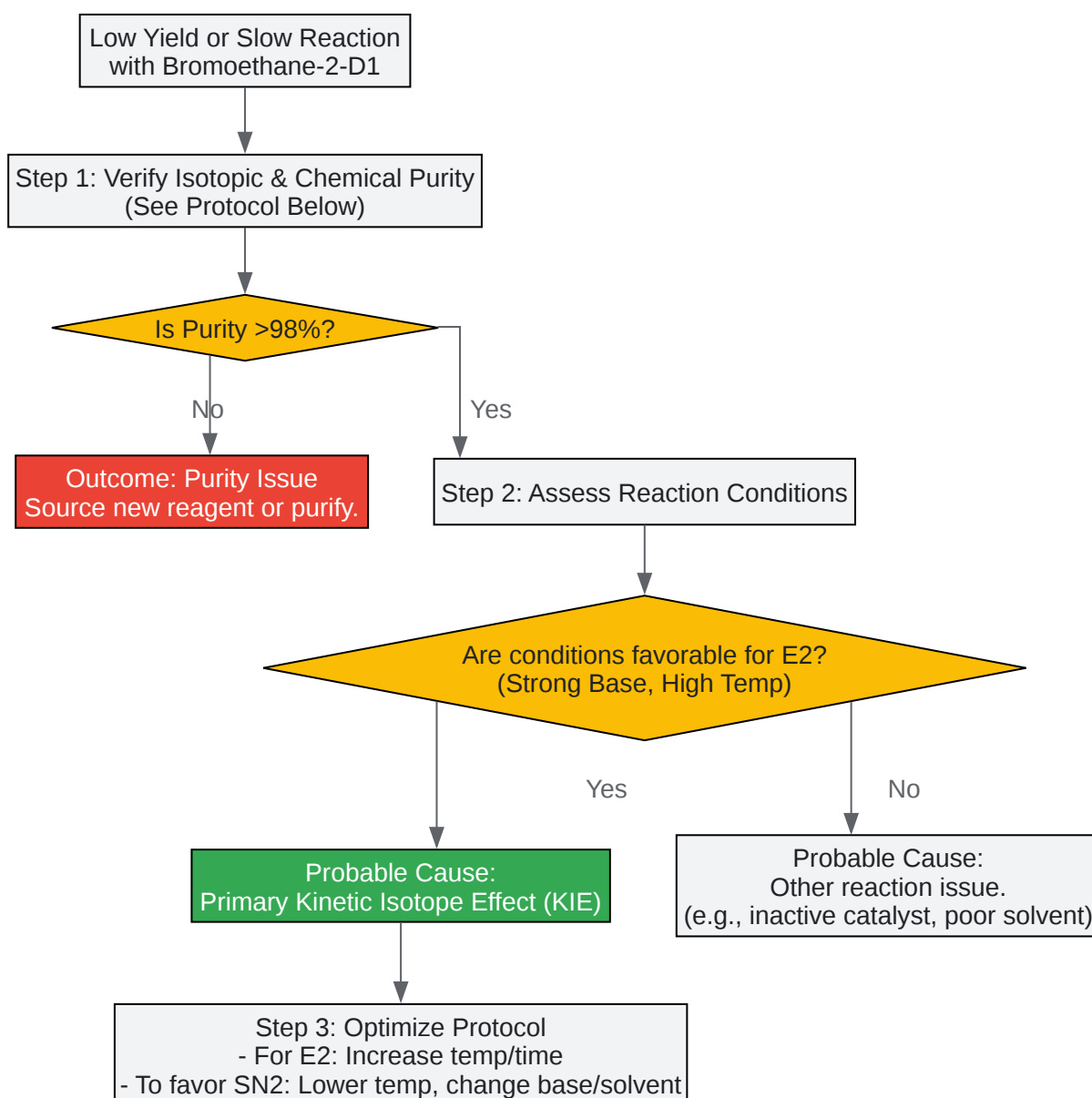

[Click to download full resolution via product page](#)

Caption: A decision-tree workflow for troubleshooting low yields.

Q2: I'm concerned about isotopic scrambling (loss of the deuterium label). How can I verify the isotopic purity of my material before and after my experiment?

Possible Cause: While thermodynamically stable, the deuterium label could potentially undergo exchange with protons if subjected to extremely harsh conditions (e.g., superbasic media, certain metal catalysts), leading to a loss of isotopic enrichment.

Solution: The two best methods for verifying isotopic purity are ^1H NMR Spectroscopy and Mass Spectrometry.

- Sample Preparation: Prepare a dilute solution of your **Bromoethane-2-D1** sample in a deuterated solvent that does not have signals in the region of interest (e.g., CDCl_3). Add a small amount of an internal standard with a known chemical shift (e.g., Tetramethylsilane, TMS at 0.0 ppm).[14]
- Acquisition: Acquire a standard ^1H NMR spectrum.
- Analysis:
 - $-\text{CH}_2\text{Br}$ Group (C1): Look for the signal corresponding to the two protons on the carbon bonded to bromine. In pure **Bromoethane-2-D1**, this signal should appear as a triplet around δ 3.4 ppm due to coupling with the two protons on the adjacent carbon.
 - $-\text{CH}_2\text{D}$ Group (C2): The signal for the methylene group containing the deuterium will be centered around δ 1.6-1.7 ppm. Its multiplicity will be complex due to coupling to both the adjacent protons and the deuterium.
 - Contamination Check: The key indicator of deuterium loss is the appearance of the classic "ethyl" pattern from unlabeled bromoethane. Look for a quartet around δ 3.4 ppm (the $-\text{CH}_2\text{Br}$ signal split by three adjacent protons) and a triplet around δ 1.68 ppm (the $-\text{CH}_3$ signal split by two adjacent protons).[14]

- Quantification: Carefully integrate the signals. The ratio of the integral of the C1 protons to the C2 protons should be 2:2 for the pure deuterated compound. The presence of a signal for a methyl group (-CH₃) indicates a loss of isotopic purity.
- Sample Introduction: Introduce a small amount of your sample into the mass spectrometer, typically using a GC-MS or direct infusion method with a suitable ionization technique (e.g., Electron Ionization, EI).
- Acquisition: Acquire the mass spectrum in the m/z range of approximately 25-120.
- Analysis:
 - Molecular Ion Peak: Bromine has two major isotopes, ⁷⁹Br and ⁸¹Br, in an approximate 1:1 natural abundance.[15] Therefore, the molecular ion (M⁺) will appear as a pair of peaks of nearly equal intensity, separated by 2 m/z units.[16]
 - Expected Peaks for Pure **Bromoethane-2-D1**:
 - m/z 109: [CH₂DCH₂⁷⁹Br]⁺
 - m/z 111: [CH₂DCH₂⁸¹Br]⁺
 - Indication of Deuterium Loss: The presence of significant peaks at m/z 108 ([CH₃CH₂⁷⁹Br]⁺) and m/z 110 ([CH₃CH₂⁸¹Br]⁺) indicates contamination with unlabeled bromoethane or loss of the deuterium label.[15]
 - Fragment Ions: Analyze key fragment ions. The loss of a bromine radical is a common fragmentation pathway. Look for a peak at m/z 30 corresponding to the [CH₂DCH₂]⁺ fragment. A prominent peak at m/z 29 would indicate the presence of the unlabeled [CH₃CH₂]⁺ fragment.[15]

Analyte	Expected Molecular Ions (m/z)	Key Fragment Ion (m/z)
Bromoethane-2-D1 (Pure)	109, 111	30
Bromoethane (Unlabeled)	108, 110	29

Q3: My goal is nucleophilic substitution, but I am forming a significant amount of an elimination byproduct. How can I optimize my reaction to favor the SN2 pathway?

Possible Cause: Your reaction conditions are promoting the competing E2 elimination reaction. This is common when using strong or sterically hindered nucleophiles, which can act as bases, or when running the reaction at elevated temperatures.[12]

Solution: To favor the SN2 pathway, you need to adjust your protocol to minimize the rate of the E2 reaction.

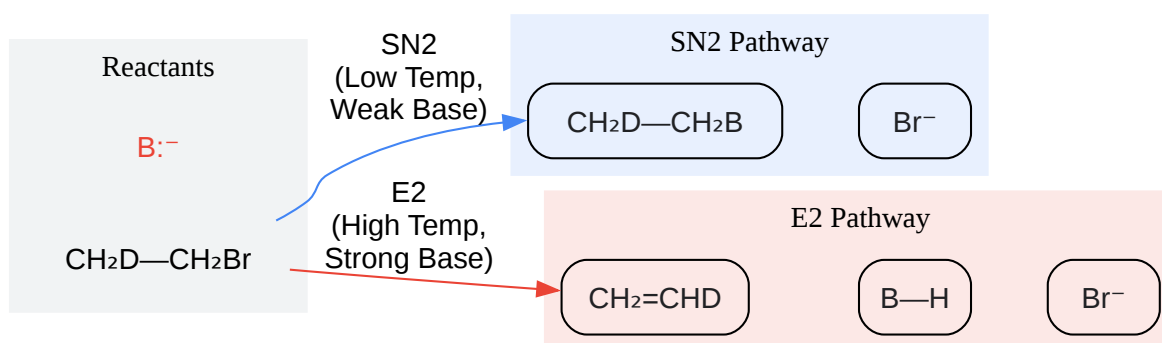

[Click to download full resolution via product page](#)

Caption: Competing SN2 and E2 reaction pathways for **Bromoethane-2-D1**.

Optimization Strategies:

- **Choice of Nucleophile/Base:** If possible, switch to a species that is a good nucleophile but a weak base. For example, iodide (I^-) and cyanide (CN^-) are excellent nucleophiles that are relatively weak bases. If you must use a strong base like hydroxide (OH^-), use water as a solvent instead of ethanol and keep the temperature low to favor substitution.[12]
- **Temperature Control:** Perform the reaction at the lowest temperature that allows for a reasonable reaction rate. Room temperature or even $0\text{ }^\circ\text{C}$ is often sufficient for SN2

reactions with good nucleophiles. Avoid heating or refluxing unless absolutely necessary.

- Solvent Choice: Use a polar aprotic solvent such as acetone, DMSO, or DMF. These solvents are excellent at solvating the cation of the nucleophilic salt but do not solvate the anion (the nucleophile) as strongly, making it more "naked" and reactive. They do not participate in elimination reactions as protic solvents can.

By carefully controlling these three factors, you can significantly shift the selectivity of your reaction towards the desired SN2 substitution product and minimize the formation of the ethene byproduct.

References

- Shiner, V. J., et al. (1995). β -Deuterium kinetic isotope effects for identity processes: bromide ion substitution at 1-bromo-1-arylethanes and 2-bromooctane. *Journal of the American Chemical Society*.
- ARMAR Isotopes. (n.d.). Bromoethane-d5: High-Quality Deuterated Solvent for Precise NMR. Retrieved from [\[Link\]](#)
- Wikipedia. (n.d.). Kinetic isotope effect. Retrieved from [\[Link\]](#)
- Doc Brown's Chemistry. (n.d.). Advanced Organic Chemistry: Mass spectrum of bromoethane. Retrieved from [\[Link\]](#)
- Chemistry LibreTexts. (2022). 11.8: The E2 Reaction and the Deuterium Isotope Effect. Retrieved from [\[Link\]](#)
- Chemdox. (n.d.). Safety Data Sheet: Bromoethane-d5. Retrieved from [\[Link\]](#)
- Doc Brown's Chemistry. (n.d.). ^1H proton nmr spectrum of bromoethane. Retrieved from [\[Link\]](#)
- FranklyChemistry. (2016, June 5). Simply Mechanisms 12a. Elimination reaction 1 (bromoethane & ethanolic KOH) [Video]. YouTube. Retrieved from [\[Link\]](#)
- Doc Brown's Chemistry. (n.d.). ^1H NMR spectrum of 1,2-dibromoethane. Retrieved from [\[Link\]](#)

- PubChem. (n.d.). **Bromoethane-2-D1**. Retrieved from [\[Link\]](#)
- Pearson+. (n.d.). The deuterium kinetic isotope effect for the halogenation of an a.... Retrieved from [\[Link\]](#)
- ResearchGate. (2014). Kinetics of 1,2-Dichloroethane and 1,2-Dibromoethane Biodegradation in Anaerobic Enrichment Cultures. Retrieved from [\[Link\]](#)
- ResearchGate. (2020). Aerobic and Anaerobic Biodegradation of 1,2-Dibromoethane by a Microbial Consortium under Simulated Groundwater Conditions. Retrieved from [\[Link\]](#)
- FranklyChemistry. (2016, June 5). Simply Mechanisms 4b: SN2. Reaction of bromoethane with KCN [Video]. YouTube. Retrieved from [\[Link\]](#)
- Canvas. (2023, December 3). Bromo pattern in Mass Spectrometry [Video]. YouTube. Retrieved from [\[Link\]](#)
- University of Ottawa. (n.d.). (Br) Bromine NMR. Retrieved from [\[Link\]](#)
- The Organic Chemistry Tutor. (2016, July 6). Haloform Reaction Base Catalyzed Bromination of Aldehyde or Ketone [Video]. YouTube. Retrieved from [\[Link\]](#)
- National Institutes of Health. (2012). Evolution of Efficient Pathways for Degradation of Anthropogenic Chemicals. Retrieved from [\[Link\]](#)
- Doc Brown's Chemistry. (n.d.). Interpreting the mass - spectrum of 1,2-dibromoethane. Retrieved from [\[Link\]](#)
- Chemistry By Dr. Anju Singh. (2020, December 15). LECTURE 12 - 1H NMR Spectrum | 1, 1-Dibromoethane | 1, 1, 2-Tribromoethane (CH₂Br-CHBr₂) | Ethanol [Video]. YouTube. Retrieved from [\[Link\]](#)
- Save My Exams. (2025). Mass Spectrometry (MS) Fragmentation Patterns (HL) (DP IB Chemistry): Revision Note. Retrieved from [\[Link\]](#)
- PubMed. (2007). Origin of a mixed brominated ethene groundwater plume: contaminant degradation pathways and reactions. Retrieved from [\[Link\]](#)

- Brainly. (2023). Propose an SN1 mechanism for the solvolysis of 3-bromo-2,3-dimethylpentane in ethanol. Retrieved from [[Link](#)]
- LearnedGuys.com. (n.d.). mass spectrometry. Retrieved from [[Link](#)]
- ChemEd X. (n.d.). Solvolysis of Bromobutane Isomers. Retrieved from [[Link](#)]
- homework lib. (2025, April 30). [Chemistry] Solvolysis of 2 -bromo-2-methylbutane in acetic acid containing potassium acetate gave [Video]. YouTube. Retrieved from [[Link](#)]
- FranklyChemistry. (2016, May 24). Simply Mechanisms 4a: SN2. Reaction of bromoethane with aqueous KOH [Video]. YouTube. Retrieved from [[Link](#)]
- Chem with Dr. G. (2024, June 17). CHEM 2325 Module 27: Haloform Reaction; Mechanism of Base-catalyzed Alpha Halogenation [Video]. YouTube. Retrieved from [[Link](#)]

Need Custom Synthesis?

BenchChem offers custom synthesis for rare earth carbides and specific isotopic labeling.

Email: info@benchchem.com or [Request Quote Online](#).

Sources

- 1. cdnisotopes.com [cdnisotopes.com]
- 2. echemi.com [echemi.com]
- 3. Kinetic isotope effect - Wikipedia [en.wikipedia.org]
- 4. chem.libretexts.org [chem.libretexts.org]
- 5. benchchem.com [benchchem.com]
- 6. clearsynth.com [clearsynth.com]
- 7. cdnisotopes.com [cdnisotopes.com]
- 8. isotope.com [isotope.com]
- 9. sds.chemdox.com [sds.chemdox.com]
- 10. armar-europa.de [armar-europa.de]

- [11. m.youtube.com \[m.youtube.com\]](https://m.youtube.com)
- [12. m.youtube.com \[m.youtube.com\]](https://m.youtube.com)
- [13. pdf.benchchem.com \[pdf.benchchem.com\]](https://pdf.benchchem.com)
- [14. C₂H₅Br CH₃CH₂Br bromoethane low high resolution 1H proton nmr spectrum of analysis interpretation of chemical shifts ppm spin spin line splitting H-1 bromoethane 1-H nmr explaining spin-spin coupling for line splitting ethyl bromide doc brown's advanced organic chemistry revision notes \[docbrown.info\]](#)
- [15. C₂H₅Br CH₃CH₂Br mass spectrum of bromoethane fragmentation pattern of m/z m/e ions for analysis and identification of bromoethane ethyl bromide image diagram doc brown's advanced organic chemistry revision notes \[docbrown.info\]](#)
- [16. savemyexams.com \[savemyexams.com\]](https://savemyexams.com)
- To cite this document: BenchChem. [Stability of Bromoethane-2-D1 under experimental conditions.]. BenchChem, [2026]. [Online PDF]. Available at: [\[https://www.benchchem.com/product/b3044131/docs#stability-of-bromoethane-2-d1-under-experimental-conditions\]](https://www.benchchem.com/product/b3044131/docs#stability-of-bromoethane-2-d1-under-experimental-conditions)

Disclaimer & Data Validity:

The information provided in this document is for Research Use Only (RUO) and is strictly not intended for diagnostic or therapeutic procedures. While BenchChem strives to provide accurate protocols, we make no warranties, express or implied, regarding the fitness of this product for every specific experimental setup.

Technical Support: The protocols provided are for reference purposes. Unsure if this reagent suits your experiment?

Need Industrial/Bulk Grade? [Request Custom Synthesis Quote](#)

BenchChem

Our mission is to be the trusted global source of essential and advanced chemicals, empowering scientists and researchers to drive progress in science and industry.

Contact

Address: 3281 E Guasti Rd
Ontario, CA 91761, United States
Phone: (601) 213-4426
Email: info@benchchem.com

Contact our Ph.D. Support Team for a compatibility check