

# Application Note: Structural Confirmation of 10-Methylhexadecanoic Acid using NMR Spectroscopy

**Author:** BenchChem Technical Support Team. **Date:** April 2026

## Compound of Interest

Compound Name: 10-Methylhexadecanoic acid

CAS No.: 17001-26-2

Cat. No.: B3044267

[Get Quote](#)

Audience: Researchers, scientists, and drug development professionals.

## Introduction

**10-Methylhexadecanoic acid** is a branched-chain fatty acid that has been identified in various natural sources.[1][2] Nuclear Magnetic Resonance (NMR) spectroscopy is a powerful non-destructive analytical technique for the structural elucidation and confirmation of such molecules.[3] This application note provides a detailed protocol for the structural confirmation of **10-methylhexadecanoic acid** using  $^1\text{H}$  and  $^{13}\text{C}$  NMR spectroscopy.

## Key Structural Features to Confirm by NMR:

- Carboxylic Acid Moiety: The presence of the characteristic proton and carbon signals of the -COOH group.
- Methyl Branch: Confirmation of the methyl group at the C-10 position through its distinct chemical shift and multiplicity.

- Acyl Chain: Verification of the length and nature of the long aliphatic chain.
- Terminal Methyl Group: Identification of the signal corresponding to the methyl group at the end of the acyl chain.

## Experimental Protocols

### Sample Preparation

Proper sample preparation is crucial for obtaining high-quality NMR spectra.

- Sample Purity: Ensure the **10-methylhexadecanoic acid** sample is of high purity to avoid signals from contaminants.
- Solvent Selection: Deuterated chloroform ( $\text{CDCl}_3$ ) is a common and suitable solvent for fatty acids. Other deuterated organic solvents can also be used.
- Concentration:
  - For  $^1\text{H}$  NMR, dissolve 5-10 mg of the sample in approximately 0.6-0.7 mL of deuterated solvent.[\[4\]](#)
  - For  $^{13}\text{C}$  NMR, a higher concentration of 20-50 mg in 0.6-0.7 mL of solvent is recommended due to the lower natural abundance of the  $^{13}\text{C}$  isotope.[\[4\]](#)
- Procedure:
  - Accurately weigh the sample and transfer it to a clean, dry vial.
  - Add the deuterated solvent and gently vortex or sonicate to ensure complete dissolution.
  - Filter the solution through a small plug of glass wool in a Pasteur pipette directly into a 5 mm NMR tube to remove any particulate matter.[\[4\]](#)
  - Add a small amount of tetramethylsilane (TMS) as an internal standard for chemical shift referencing ( $\delta = 0.00$  ppm).

### NMR Data Acquisition

The following are general parameters for acquiring  $^1\text{H}$  and  $^{13}\text{C}$  NMR spectra. These may need to be optimized based on the specific NMR instrument used.

- Instrument: A 400 MHz or higher field NMR spectrometer is recommended for better signal dispersion.
- $^1\text{H}$  NMR Spectroscopy:
  - Pulse Program: Standard single-pulse experiment (zg30 or similar).
  - Spectral Width: 12-16 ppm.
  - Acquisition Time: 2-4 seconds.
  - Relaxation Delay (d1): 1-5 seconds.
  - Number of Scans: 16-64, depending on the sample concentration.
- $^{13}\text{C}$  NMR Spectroscopy:
  - Pulse Program: Proton-decoupled experiment (e.g., zgpg30).
  - Spectral Width: 200-240 ppm.
  - Acquisition Time: 1-2 seconds.
  - Relaxation Delay (d1): 2-5 seconds.
  - Number of Scans: 1024-4096 or more, as needed to achieve a good signal-to-noise ratio.

## Data Presentation: Predicted NMR Data

The following tables summarize the predicted  $^1\text{H}$  and  $^{13}\text{C}$  NMR chemical shifts for **10-methylhexadecanoic acid**. These predictions are based on known chemical shift values for similar long-chain fatty acids and the analysis of its methyl ester.<sup>[5]</sup>

### Table 1: Predicted $^1\text{H}$ NMR Data for 10-Methylhexadecanoic Acid

Proton Assignment	Chemical Shift ( $\delta$ , ppm)	Multiplicity	Integration
H-1 (COOH)	~10-12	broad singlet	1H
H-2 ( $\alpha$ -CH <sub>2</sub> )	~2.35	triplet	2H
H-3 ( $\beta$ -CH <sub>2</sub> )	~1.63	multiplet	2H
H-10 (CH)	~1.55	multiplet	1H
Bulk CH <sub>2</sub> (H-4 to H-9, H-11 to H-15)	~1.25	broad multiplet	22H
H-16 (CH <sub>3</sub> )	~0.88	triplet	3H
C10-CH <sub>3</sub>	~0.86	doublet	3H

**Table 2: Predicted <sup>13</sup>C NMR Data for 10-Methylhexadecanoic Acid**

Carbon Assignment	Chemical Shift ( $\delta$ , ppm)
C-1 (COOH)	~180
C-2 ( $\alpha$ -CH <sub>2</sub> )	~34.0
C-3 ( $\beta$ -CH <sub>2</sub> )	~24.7
C-10 (CH)	~32.8
C-16 (CH <sub>3</sub> )	~14.1
C10-CH <sub>3</sub>	~19.7
Bulk CH <sub>2</sub>	~22.7 - 31.9

## Visualization of Experimental Workflow and Structural Analysis

The following diagrams illustrate the workflow for NMR-based structural confirmation and the logical connections between the NMR data and the molecular structure.

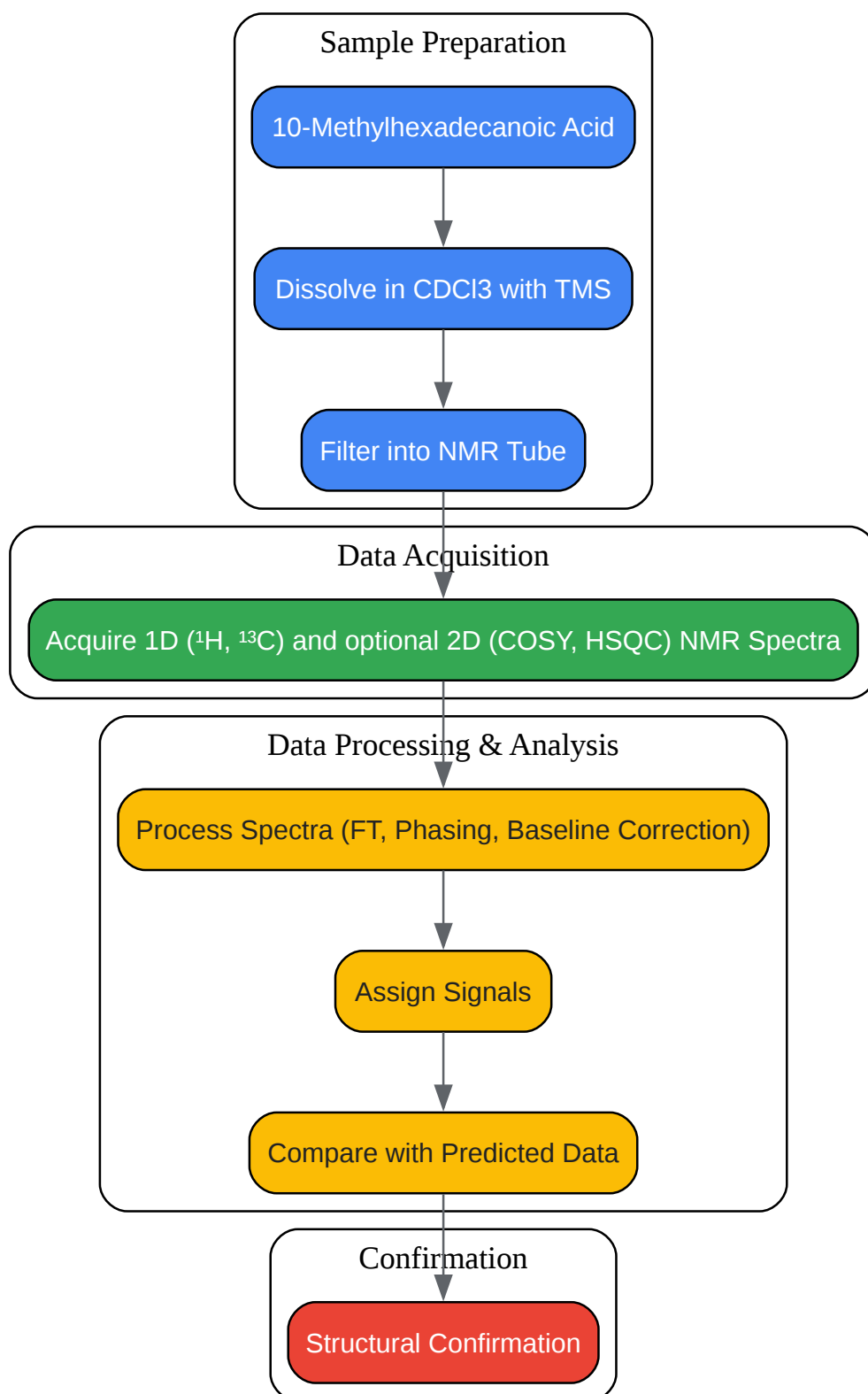

[Click to download full resolution via product page](#)

Caption: Experimental workflow for NMR-based structural confirmation.

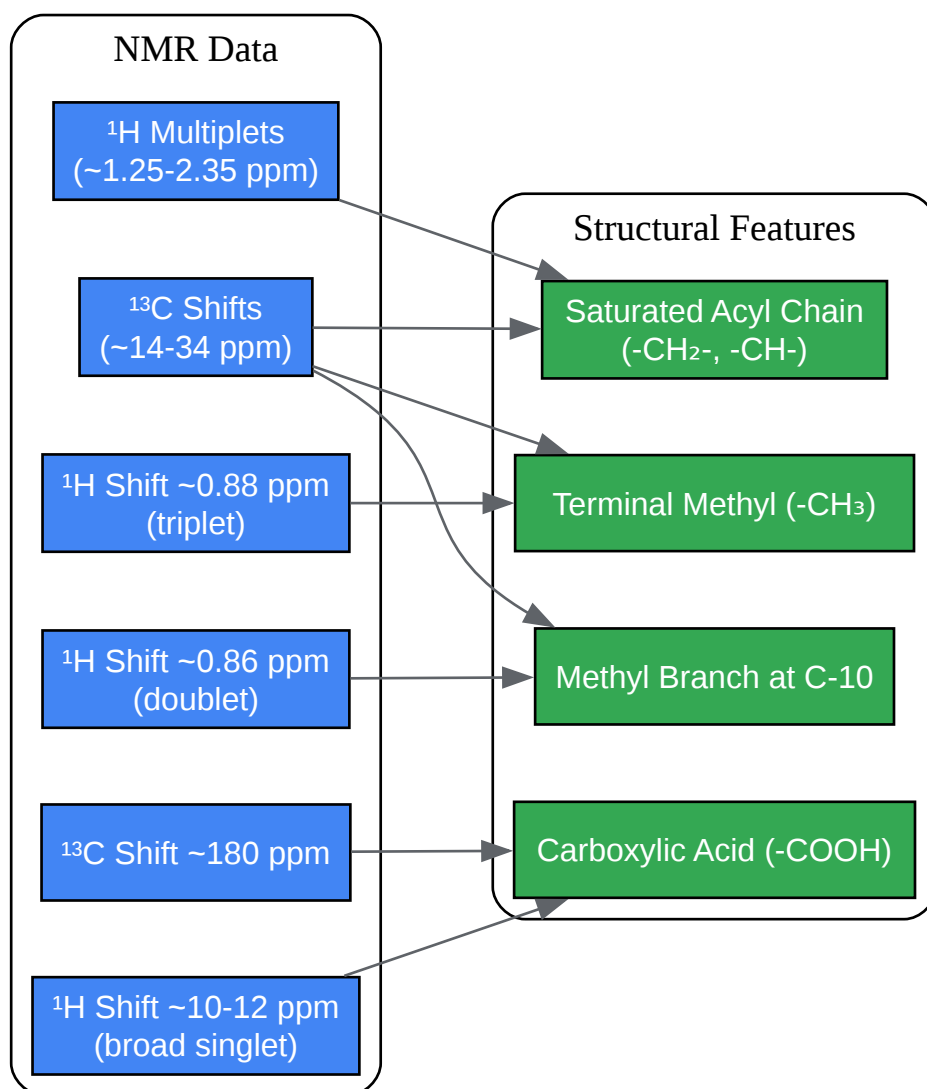

[Click to download full resolution via product page](#)

Caption: Correlation of NMR data to structural features.

### Need Custom Synthesis?

BenchChem offers custom synthesis for rare earth carbides and specific isotopic labeling.

Email: [info@benchchem.com](mailto:info@benchchem.com) or [Request Quote Online](#).

## References

- 1. NP-MRD: Showing NP-Card for 10-methylhexadecanoic acid (NP0325859) [np-mrd.org]

- [2. 10-Methylhexadecanoic acid | C17H34O2 | CID 5312292 - PubChem \[pubchem.ncbi.nlm.nih.gov\]](#)
- [3. myneni.princeton.edu \[myneni.princeton.edu\]](#)
- [4. NP-MRD: Showing NP-Card for 10-Methylheptadecanoic acid \(NP0083682\) \[np-mrd.org\]](#)
- [5. aocs.org \[aocs.org\]](#)
- To cite this document: BenchChem. [Application Note: Structural Confirmation of 10-Methylhexadecanoic Acid using NMR Spectroscopy]. BenchChem, [2026]. [Online PDF]. Available at: [<https://www.benchchem.com/product/b3044267/docs#application-note-structural-confirmation-of-10-methylhexadecanoic-acid-using-nmr-spectroscopy>]

---

### Disclaimer & Data Validity:

The information provided in this document is for Research Use Only (RUO) and is strictly not intended for diagnostic or therapeutic procedures. While BenchChem strives to provide accurate protocols, we make no warranties, express or implied, regarding the fitness of this product for every specific experimental setup.

**Technical Support:** The protocols provided are for reference purposes. Unsure if this reagent suits your experiment?

**Need Industrial/Bulk Grade?** [Request Custom Synthesis Quote](#)

## BenchChem

Our mission is to be the trusted global source of essential and advanced chemicals, empowering scientists and researchers to drive progress in science and industry.

### Contact

Address: 3281 E Guasti Rd  
Ontario, CA 91761, United States  
Phone: (601) 213-4426  
Email: [info@benchchem.com](mailto:info@benchchem.com)

Contact our Ph.D. Support Team for a compatibility check