

# Technical Guide: Selective Bromination of 2-Fluoro-4-iodotoluene[1]

**Author:** BenchChem Technical Support Team. **Date:** April 2026

## Compound of Interest

Compound Name:	1-(Bromomethyl)-2-fluoro-4-iodobenzene
CAS No.:	85510-81-2
Cat. No.:	B3043385

[Get Quote](#)

## Executive Summary

The bromination of 2-Fluoro-4-iodotoluene (CAS 39998-81-7) is a pivotal transformation in the synthesis of high-value pharmaceutical intermediates.[1] Depending on the reaction conditions applied, the substrate undergoes two distinct mechanistic pathways yielding vastly different products:

- Radical Substitution (Wohl-Ziegler): Yields 2-Fluoro-4-iodobenzyl bromide (CAS 85510-81-2).[1] This is the primary "building block" of interest for drug development, serving as a linker in the synthesis of imidazole-based antifungals and receptor antagonists.
- Electrophilic Aromatic Substitution (EAS): Yields ring-brominated species, primarily 5-bromo-2-fluoro-4-iodotoluene.[1] This pathway is often a source of impurities but can be exploited for poly-halogenated scaffold generation.[1]

This guide prioritizes the benzylic bromination protocol due to its industrial relevance, while providing a mechanistic contrast to the EAS pathway to ensure comprehensive impurity

management.

## Mechanistic Pathways & Regioselectivity[2]

Understanding the electronic and steric environment of the substrate is critical for controlling the reaction outcome.

### Substrate Analysis

The starting material, 2-Fluoro-4-iodotoluene, presents a competitive landscape for substitution:

- Methyl Group ( ): Activates the ring (weakly) and is susceptible to H-abstraction by radicals.
- Fluoro Group ( ): Strong -withdrawer (deactivating) but -donor (ortho/para directing).[1]
- Iodo Group ( ): Weak deactivator, ortho/para directing.

### Pathway A: Radical Benzylic Bromination (Target)

Under radical conditions (NBS/AIBN), the reaction is driven by the stability of the benzylic radical. The fluorine and iodine atoms on the ring exert an inductive effect that slightly destabilizes the benzylic radical compared to toluene, requiring precise thermal control to prevent gem-dibromination.

### Pathway B: Electrophilic Aromatic Substitution (Impurity/Alternative)

In the presence of Lewis acids (e.g.,

) or absence of light/initiator,

attacks the ring.

- Directing Logic:

- F (

- ) : Directs to

- (ortho) and

- (para).

- I (

- ) : Directs to

- and

- (ortho).

- Me (

- ) : Directs to

- (ortho).

- Outcome:

is the most electronically activated position (Para to F, Ortho to I).

is sterically crowded (sandwiched between F and I). Therefore, 5-bromo-2-fluoro-4-iodotoluene is the predicted major EAS product.[\[1\]](#)

## Decision Logic Diagram

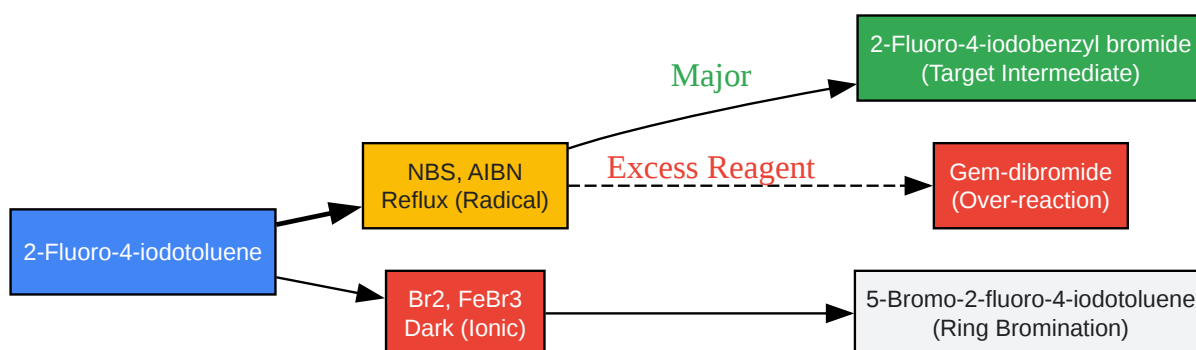

[Click to download full resolution via product page](#)

Caption: Divergent reaction pathways based on catalytic environment. Pathway A (top) is the industry standard for linker synthesis.

## Experimental Protocol: Synthesis of 2-Fluoro-4-iodobenzyl bromide

This protocol utilizes

-Trifluorotoluene (PhCF<sub>3</sub>) as a greener, higher-boiling alternative to Carbon Tetrachloride ( ), offering improved kinetics and safety profile.

### Materials & Reagents

Reagent	Equiv.	Role	Critical Note
2-Fluoro-4-iodotoluene	1.0	Substrate	Ensure purity >98% to avoid isomeric mixtures.
N-Bromosuccinimide (NBS)	1.05	Bromine Source	Recrystallize from water if yellow (indicates free ).[1]
AIBN	0.05	Radical Initiator	Azobisisobutyronitrile. Store cold.
Trifluorotoluene	Solvent	Medium	Sparge with Argon to remove (radical quencher).

## Step-by-Step Procedure

- Setup: Equip a 3-neck round-bottom flask with a magnetic stir bar, reflux condenser, and nitrogen inlet.
- Dissolution: Charge 2-Fluoro-4-iodotoluene (10.0 g, 42.4 mmol) and Trifluorotoluene (100 mL). Stir to dissolve.
- Activation: Add N-Bromosuccinimide (7.92 g, 44.5 mmol) and AIBN (348 mg, 2.1 mmol).
  - Note: The NBS will not fully dissolve initially. It is denser than the solvent and will sit at the bottom.
- Reaction: Heat the mixture to reflux (
  - Observation: As the reaction proceeds, the dense NBS (succinimide precursor) converts to Succinimide, which is less dense and will float to the surface. This "flip" is a visual indicator of progress.

- Time: Typically 4–6 hours. Monitor by TLC (Hexanes/EtOAc 9:1) or HPLC. Look for the disappearance of the starting material ( ) and appearance of the mono-bromide ( ).
- Workup:
  - Cool the reaction mixture to . Succinimide will precipitate fully.
  - Filter off the solid Succinimide. Rinse the filter cake with cold solvent.
  - Wash the filtrate with water ( mL) and brine ( mL).
  - Dry over anhydrous and concentrate under reduced pressure.
- Purification:
  - The crude residue is often a yellow oil or low-melting solid.<sup>[1]</sup>
  - Preferred: Recrystallization from Heptane. Heat to dissolve, then cool slowly to .
  - Alternative: Flash Column Chromatography (100% Hexanes 5% EtOAc/Hexanes). Warning: Benzyl halides can degrade on silica; use neutral alumina if unstable.

## Characterization Data (Expected)

- <sup>1</sup>H NMR (400 MHz, CDCl<sub>3</sub>):

- 7.50 (dd, 1H, -5), 7.40 (dd, 1H, -3), 7.15 (t, 1H, -6).
- 4.45 (s, 2H, ). Key diagnostic peak.
- MS (EI): Molecular ion peaks at m/z 314/316 (M+ for Br isotopes) and fragment at m/z 235 (loss of Br).

## Troubleshooting & Optimization

### Controlling Di-bromination

A common failure mode is the formation of the gem-dibromide (benzal bromide).[1]

- Cause: Excess NBS or prolonged reaction time after consumption of starting material.
- Solution: Stop the reaction at 95% conversion rather than 100%. It is easier to separate starting material (non-polar) than the dibromide (similar polarity to product) during crystallization.

### Handling "Stalled" Reactions

If the reaction stalls at 50% conversion:

- Cause: Exhaustion of initiator or quenching by oxygen.
- Fix: Add a second portion of AIBN (0.02 eq) and ensure vigorous reflux. Do not add more NBS unless you confirm it has been consumed.

### Safety & Handling

- Lachrymator: 2-Fluoro-4-iodobenzyl bromide is a potent lachrymator (tear gas agent).[1] All operations, especially weighing and rotary evaporation, must occur in a functioning fume hood.

- Waste: Segregate halogenated waste. Succinimide byproduct is non-toxic but should be disposed of as solid chemical waste.

## Workflow Visualization

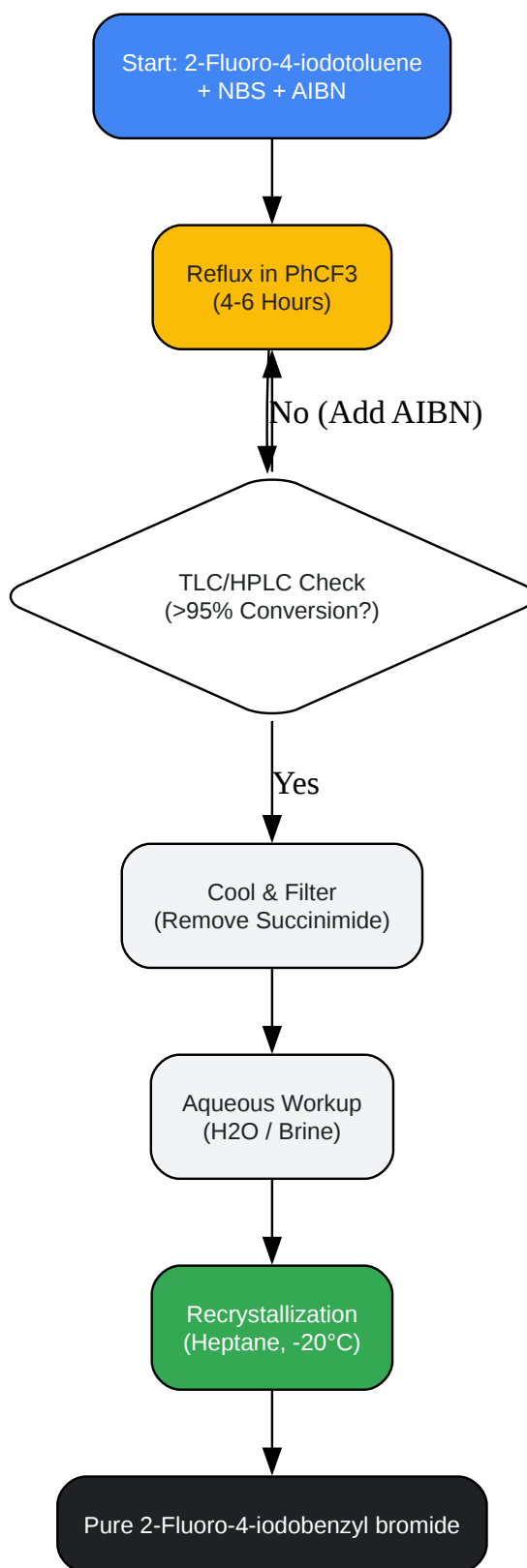

[Click to download full resolution via product page](#)

Caption: Operational workflow for the synthesis and purification of the benzyl bromide.

## References

- Djerassi, C. (1948). Brominations with N-Bromosuccinimide.[1][2] *Chemical Reviews*, 43(2), 271–317. (Classic mechanistic reference for Wohl-Ziegler).
- Podgoršek, A., et al. (2009). Green halogenation of organic compounds. *Angewandte Chemie International Edition*, 48(45), 8424-8450. (Source for PhCF<sub>3</sub> solvent substitution).

### Need Custom Synthesis?

BenchChem offers custom synthesis for rare earth carbides and specific isotopic labeling.

Email: [info@benchchem.com](mailto:info@benchchem.com) or [Request Quote Online](#).

## Sources

- 1. [1824274-98-7|2,3-Difluoro-4-iodobenzyl bromide|BLD Pharm \[bldpharm.com\]](#)
- 2. [taylorandfrancis.com \[taylorandfrancis.com\]](#)
- To cite this document: BenchChem. [Technical Guide: Selective Bromination of 2-Fluoro-4-iodotoluene[1]]. BenchChem, [2026]. [Online PDF]. Available at: [\[https://www.benchchem.com/product/b3043385/docs#technical-guide-selective-bromination-of-2-fluoro-4-iodotoluene-1\]](https://www.benchchem.com/product/b3043385/docs#technical-guide-selective-bromination-of-2-fluoro-4-iodotoluene-1)

### Disclaimer & Data Validity:

The information provided in this document is for Research Use Only (RUO) and is strictly not intended for diagnostic or therapeutic procedures. While BenchChem strives to provide accurate protocols, we make no warranties, express or implied, regarding the fitness of this product for every specific experimental setup.

**Technical Support:** The protocols provided are for reference purposes. Unsure if this reagent suits your experiment?

**Need Industrial/Bulk Grade?** [Request Custom Synthesis Quote](#)

# BenchChem

Our mission is to be the trusted global source of essential and advanced chemicals, empowering scientists and researchers to drive progress in science and industry.

## Contact

Address: 3281 E Guasti Rd

Ontario, CA 91761, United States

Phone: (601) 213-4426

Email: [info@benchchem.com](mailto:info@benchchem.com)

[Contact our Ph.D. Support Team for a compatibility check](#)