

# Maltooctaose as a Reference Standard for Oligosaccharide Analysis: A Comparative Guide

**Author:** BenchChem Technical Support Team. **Date:** April 2026

## Compound of Interest

Compound Name:	Maltooctaose
CAS No.:	66567-45-1
Cat. No.:	B3042742

[Get Quote](#)

In the landscape of oligosaccharide analysis, the choice of a reference standard is paramount for accurate quantification and reliable characterization. **Maltooctaose**, a linear oligosaccharide composed of eight  $\alpha$ -1,4 linked glucose units, has emerged as a valuable tool for researchers, scientists, and drug development professionals. This guide provides an objective comparison of **maltooctaose**'s performance against other commonly used reference standards, supported by experimental data and detailed protocols.

## The Role of Maltooctaose in Oligosaccharide Analysis

**Maltooctaose** serves as a critical reference material in various analytical techniques due to its well-defined structure and high purity.<sup>[1]</sup> It is particularly useful in methods such as High-Performance Anion-Exchange Chromatography with Pulsed Amperometric Detection (HPAEC-PAD) and Liquid Chromatography-Mass Spectrometry (LC-MS), which are instrumental in the quality control of food and beverages, enzyme activity assays, and biopharmaceutical research.<sup>[1]</sup>

## Comparative Analysis of Oligosaccharide Reference Standards

The selection of an appropriate reference standard depends on the specific analytical method and the nature of the oligosaccharides being investigated. While **maltooctaose** offers excellent performance, other standards such as dextran ladders, fructooligosaccharides, and chitooligosaccharides are also employed.

### Data Presentation: Quantitative Comparison of Reference Standards

The following tables summarize key performance indicators for **maltooctaose** and its alternatives based on data from various analytical studies.

Feature	Maltooctaose/ Maltooligosaccharides	Dextran Ladder	Fructooligosaccharides (FOS)	Chitooligosaccharides (COS)
Typical Concentration Range (HPAEC-PAD)	0.1 - 50 µg/mL[1]	N/A (Used for calibration)	N/A	0.2 - 10 mg/L[2]
Typical Concentration Range (LC-MS)	1 mM[1]	N/A	N/A	N/A
Limit of Detection (LOD) (HPAEC-PAD)	0.01 - 0.1 mg/L[3]	N/A	N/A	0.003 - 0.016 mg/L[2]
Linearity (R <sup>2</sup> ) (HPAEC-PAD)	> 0.999[3]	N/A	N/A	0.9979–0.9995[2]
Primary Application	Quantification of maltooligosaccharides	Retention time calibration (GU values)[4][5]	Quantification of fructans in food[6]	Quantification of chitosan derivatives[2]
Key Advantage	Structurally defined single compound	Broad molecular weight coverage	Relevant for prebiotic food analysis	Specific to amino-sugars
Key Limitation	Limited to α-1,4-glucans	Polydisperse mixture	Different linkage types (β-2,1)	Not suitable for neutral oligosaccharides

Table 1: Comparison of key analytical parameters for different oligosaccharide reference standards.

Analytical Method	Oligosaccharide	Degree of Polymerization (DP)	Recovery (%)
LC-MS	Maltotriose	3	69.0
	Maltotetraose	4	85.8
	Maltopentaose	5	89.8
	Maltohexaose	6	82.5

Table 2: Recovery analysis of maltooligosaccharides in an LC-MS workflow.[1]

## Experimental Protocols

Detailed methodologies are crucial for reproducible and accurate oligosaccharide analysis. The following are representative protocols for HPAEC-PAD and LC-MS using maltooligosaccharide standards.

### Experimental Protocol 1: HPAEC-PAD Analysis of Oligosaccharides

This protocol is suitable for the quantification of maltooligosaccharides in various samples.

#### 1. Standard and Sample Preparation:

- **Maltooctaose** Stock Solution (1 mg/mL): Accurately weigh 10 mg of **maltooctaose** powder and dissolve it in 10 mL of deionized water.[1]
- Calibration Standards: Prepare a series of dilutions from the stock solution to cover the desired concentration range (e.g., 0.1 - 50 µg/mL).[1]
- Sample Preparation: Dilute the sample with deionized water to fall within the calibration range. For complex matrices, a solid-phase extraction (SPE) cleanup may be necessary.

#### 2. HPAEC-PAD System and Conditions:

- Instrument: A high-performance anion-exchange chromatography system equipped with a pulsed amperometric detector with a gold working electrode.[7]

- Column: A suitable anion-exchange column for carbohydrate analysis (e.g., Dionex CarboPac™ PA200).[8]
- Mobile Phase A: 0.1 M Sodium Hydroxide (NaOH).[7]
- Mobile Phase B: 1 M Sodium Acetate (NaOAc) in 0.1 M NaOH.[7]
- Gradient: A linear gradient of Mobile Phase B is typically used to elute oligosaccharides of increasing size. For example, a gradient of 0-10% B over 10 minutes.[7]
- Flow Rate: 0.3 mL/min.[7]
- Column Temperature: 20 °C.[7]
- Injection Volume: 10 - 25 µL.[1]

### 3. Data Analysis:

- Integrate the peak areas of the **maltooctaose** standards and the corresponding peaks in the samples.
- Construct a calibration curve by plotting peak area versus concentration for the standards.
- Determine the concentration of maltooligosaccharides in the samples from the calibration curve.

### Experimental Protocol 2: LC-MS Analysis of Oligosaccharides

This protocol provides a general workflow for the qualitative and quantitative analysis of oligosaccharides.

#### 1. Standard and Sample Preparation:

- **Maltooctaose** Stock Solution (1 mM): Prepare a 1 mM stock solution of **maltooctaose** in deionized water.[1]
- Internal Standard: If necessary, add a suitable internal standard to all samples and standards.

- Sample Preparation: Dilute samples in the initial mobile phase. Derivatization (e.g., permethylation) may be performed to improve ionization efficiency and chromatographic separation.[9][10]

## 2. LC-MS System and Conditions:

- Instrument: A liquid chromatography system coupled to a mass spectrometer (e.g., Q-TOF or Triple Quadrupole).[11]
- Column: A column suitable for oligosaccharide separation, such as a porous graphitized carbon (PGC) or hydrophilic interaction liquid chromatography (HILIC) column.[12]
- Mobile Phase A: Water with a suitable modifier (e.g., 0.1% formic acid or 10 mM ammonium bicarbonate).[9]
- Mobile Phase B: Acetonitrile with the same modifier.
- Gradient: A gradient from high aqueous to high organic mobile phase is typically used.
- Flow Rate: Dependent on the column dimensions.
- Ionization Source: Electrospray Ionization (ESI) is commonly used.[3]
- MS Detection: Full scan mode for qualitative analysis and selected ion monitoring (SIM) or multiple reaction monitoring (MRM) for quantitative analysis.[9][11]

## 3. Data Analysis:

- Identify oligosaccharides based on their mass-to-charge ratio ( $m/z$ ) and fragmentation patterns.
- For quantitative analysis, create a calibration curve using the peak areas of the **maltooctaose** standards.
- Calculate the concentration of the target oligosaccharides in the samples.

## Mandatory Visualization

The following diagrams illustrate the logical workflow for oligosaccharide analysis using a reference standard.

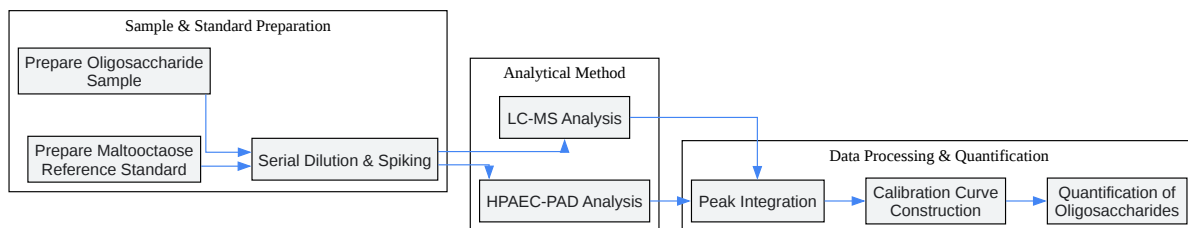

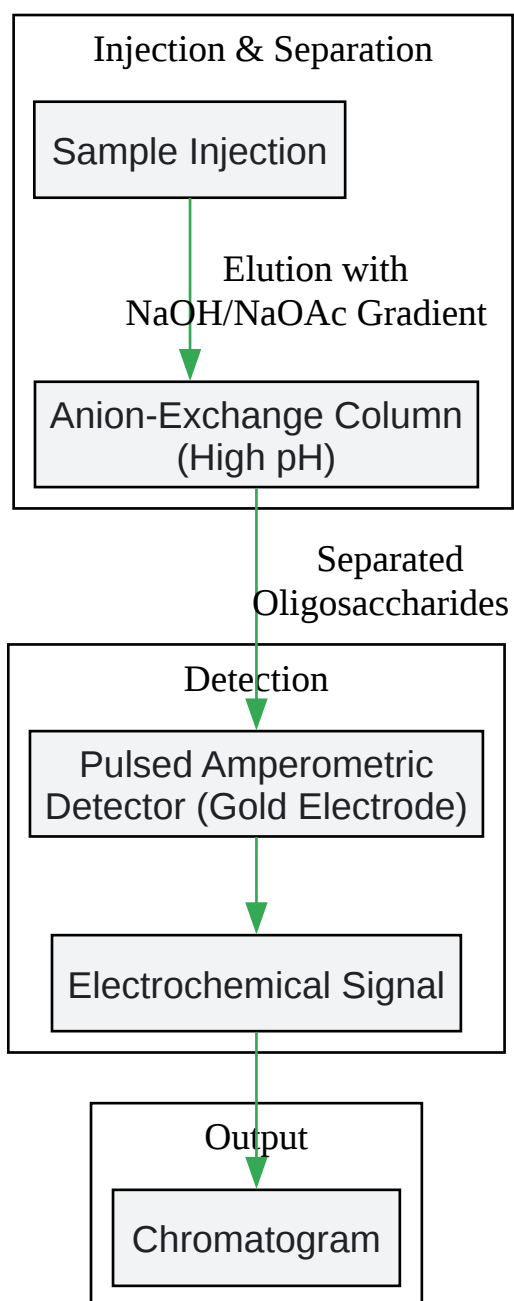

[Click to download full resolution via product page](#)

### Need Custom Synthesis?

BenchChem offers custom synthesis for rare earth carbides and specific isotopic labeling.

Email: [info@benchchem.com](mailto:info@benchchem.com) or [Request Quote Online](#).

## References

- [1. benchchem.com \[benchchem.com\]](#)
- [2. Validated HPAEC-PAD Method for the Determination of Fully Deacetylated Chitooligosaccharides - PMC \[pmc.ncbi.nlm.nih.gov\]](#)
- [3. benchchem.com \[benchchem.com\]](#)
- [4. lcms.cz \[lcms.cz\]](#)
- [5. Dextran as internal calibrant for N-glycan analysis by liquid chromatography coupled to ion mobility-mass spectrometry - PMC \[pmc.ncbi.nlm.nih.gov\]](#)
- [6. researchgate.net \[researchgate.net\]](#)
- [7. Combining HPAEC-PAD, PGC-LC–MS, and 1D 1H NMR to Investigate Metabolic Fates of Human Milk Oligosaccharides in 1-Month-Old Infants: a Pilot Study - PMC \[pmc.ncbi.nlm.nih.gov\]](#)
- [8. documents.thermofisher.com \[documents.thermofisher.com\]](#)
- [9. escholarship.org \[escholarship.org\]](#)
- [10. lebrilla.faculty.ucdavis.edu \[lebrilla.faculty.ucdavis.edu\]](#)
- [11. pubs.acs.org \[pubs.acs.org\]](#)
- [12. researchgate.net \[researchgate.net\]](#)
- [To cite this document: BenchChem. \[Maltotriose as a Reference Standard for Oligosaccharide Analysis: A Comparative Guide\]. BenchChem, \[2026\]. \[Online PDF\]. Available at: \[https://www.benchchem.com/product/b3042742/docs#maltotriose-as-a-reference-standard-for-oligosaccharide-analysis-a-comparative-guide\]](#)

---

### Disclaimer & Data Validity:

The information provided in this document is for Research Use Only (RUO) and is strictly not intended for diagnostic or therapeutic procedures. While BenchChem strives to provide accurate protocols, we make no warranties, express or implied, regarding the fitness of this product for every specific experimental setup.

**Technical Support:** The protocols provided are for reference purposes. Unsure if this reagent suits your experiment?

**Need Industrial/Bulk Grade?** [Request Custom Synthesis Quote](#)

## BenchChem

Our mission is to be the trusted global source of essential and advanced chemicals, empowering scientists and researchers to drive progress in science and industry.

### Contact

Address: 3281 E Guasti Rd  
Ontario, CA 91761, United States  
Phone: (601) 213-4426  
Email: [info@benchchem.com](mailto:info@benchchem.com)

[Contact our Ph.D. Support Team for a compatibility check](#)