

# Application Note: High-Performance Terphenyl-Based Liquid Crystalline Epoxy Resins

**Author:** BenchChem Technical Support Team. **Date:** April 2026

## Compound of Interest

**Compound Name:** 4-[4-(4-hydroxyphenyl)phenyl]phenol

**CAS No.:** 4084-45-1

**Cat. No.:** B3041907

[Get Quote](#)

**Target Audience:** Materials Scientists, Polymer Chemists, and Biomedical Device Development Professionals  
**Focus:** Synthesis, Curing Protocols, and Thermal Management of 4,4'-Dihydroxy-p-terphenyl (DHTP) Epoxy Networks

## Executive Summary & Mechanistic Rationale

The encapsulation of high-power microelectronics and implantable biomedical devices requires materials that seamlessly integrate high thermal conductivity with exceptional chemical resistance. Conventional epoxy resins, such as diglycidyl ether of bisphenol A (DGEBA), form amorphous, randomly crosslinked networks. This structural disorder induces severe phonon scattering, limiting intrinsic thermal conductivity to a mere  $\sim 0.17$  W/m·K<sup>[1]</sup>.

To overcome this thermodynamic bottleneck, Liquid Crystalline Epoxy Resins (LCERs) utilize rigid, rod-like mesogenic monomers that self-assemble into highly ordered domains during the curing process. While early LCERs relied on Schiff base (-C=N-) linkages, these are notoriously susceptible to hydrolytic degradation in acidic or physiological environments<sup>[2]</sup>.

The Terphenyl Advantage: Incorporating 4,4''-dihydroxy-p-terphenyl (DHTP) as the mesogenic core fundamentally solves this stability issue. The terphenyl scaffold consists entirely of robust C-C aromatic bonds, rendering the resulting network highly resistant to acid hydrolysis[2]. Furthermore, the extended  $\pi$ -conjugation and extreme rigidity of the terphenyl core drive the formation of highly oriented smectic (Sm) liquid crystalline phases. These ordered domains act as efficient "highways" for phonon transport, dramatically suppressing scattering and nearly doubling the intrinsic thermal conductivity of the pristine resin[3].

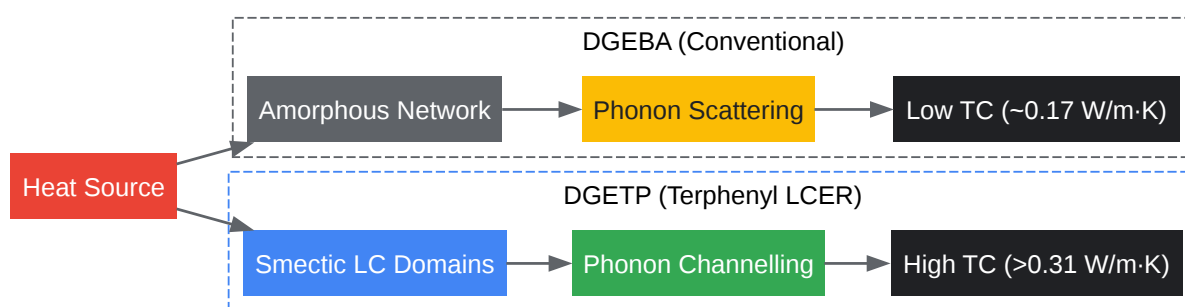

[Click to download full resolution via product page](#)

Caption: Phonon transport mechanisms in amorphous vs. smectic liquid crystalline epoxy networks.

## Quantitative Benchmarking

The structural advantages of the DHTP-based epoxy (DGETP) translate directly into measurable macroscopic properties. Table 1 summarizes the performance leap achieved by replacing standard DGEBA or Schiff-base LCERs with the terphenyl architecture.

Table 1: Comparative Thermomechanical and Chemical Properties of Epoxy Networks

Property	DGEBA (Standard)	Schiff-Base LCER	DGETP (Terphenyl LCER)
Intrinsic Thermal Conductivity	~0.17 W/m·K	~0.25 W/m·K	0.31 W/m·K[3]
Fracture Toughness	~0.15 kJ/m <sup>2</sup>	0.38 kJ/m <sup>2</sup>	>1.50 kJ/m <sup>2</sup> [2]
Acid Resistance (28 days, HCl)	Moderate degradation	Complete decomposition	No decomposition[2]
Phase Structure	Amorphous	Nematic / Smectic	Highly Ordered Smectic[3]

## Experimental Protocols

### Protocol A: Synthesis of Diglycidyl Ether of 4,4''-Dihydroxy-p-terphenyl (DGETP)

Causality Note: Epichlorohydrin is used in a massive stoichiometric excess (typically 10:1) not just as a reactant, but as a reactive solvent to prevent the premature oligomerization of the rigid terphenyl core, ensuring high yields of the difunctional monomer.

#### Step-by-Step Methodology:

- **Dissolution:** In a 500 mL three-neck round-bottom flask equipped with a reflux condenser and nitrogen inlet, add 0.1 mol of 4,4''-dihydroxy-p-terphenyl and 1.0 mol of epichlorohydrin (ECH). Add 50 mL of isopropanol to enhance solubility.
- **Catalysis:** Add 2.0 g of tetrabutylammonium bromide (TBAB) as a phase transfer catalyst. Stir the mixture magnetically and heat to 80°C under a continuous nitrogen blanket.
- **Epoxidation:** Once the mixture is homogenous, begin the dropwise addition of 40 wt% aqueous NaOH (0.22 mol) over a period of 1 hour. The NaOH drives the dehydrohalogenation step, closing the epoxide rings.
- **Reaction & Distillation:** Maintain the reaction at 80°C for an additional 4 hours. Following completion, remove the unreacted ECH and isopropanol via vacuum distillation at 60°C.

- **Purification:** Dissolve the crude residue in 200 mL of chloroform. Wash the organic layer three times with deionized water to remove NaCl and residual NaOH. Dry the organic layer over anhydrous MgSO<sub>4</sub>.
- **Precipitation:** Filter the drying agent and concentrate the solution. Precipitate the DGETP monomer by dropping the concentrated solution into cold methanol. Filter and dry under vacuum at 50°C for 24 hours.



*Self-Validation Check: Determine the Epoxy Equivalent Weight (EEW) via non-aqueous titration (ASTM D1652). The theoretical EEW for DGETP is ~187 g/eq. An experimental EEW within 5% of this value confirms successful epoxidation and high monomer purity.*

---

## Protocol B: Curing Process for Smectic LC Thermosets

**Causality Note:** While latent catalysts like 1-(2-cyanoethyl)-2-undecylimidazole (CEUI) offer longer pot lives, m-phenylenediamine (m-PDA) is explicitly chosen for this protocol. The rigid aromatic structure and primary amine functionality of m-PDA facilitate strong intermolecular hydrogen bonding and  $\pi$ - $\pi$  stacking with the terphenyl core. This specific interaction nucleates larger, highly oriented smectic domains, which is the direct cause of the superior 0.31 W/m·K thermal conductivity[3].

### Step-by-Step Methodology:

- **Melting:** Heat the synthesized DGETP monomer in a vacuum oven to 160°C until it reaches an isotropic melt state.
- **Mixing:** Add a stoichiometric amount of m-PDA (amine hydrogen-to-epoxy ratio of 1:1). Stir vigorously for 3 minutes to ensure a homogenous single-phase mixture.
- **Degassing:** Immediately apply a high vacuum (<-28 inHg) for 5 minutes to remove entrapped air bubbles, which would otherwise act as phonon-scattering defects.

- Casting: Pour the degassed mixture into a pre-heated stainless steel mold treated with a fluoropolymer mold release agent.
- Step-Cure Cycle:
  - 150°C for 2 hours (Initial crosslinking and LC domain nucleation).
  - 180°C for 2 hours (Network propagation).
  - 200°C for 2 hours (Post-cure to achieve maximum glass transition temperature,  $T_g$ ).
- Cooling: Cool the mold slowly (1°C/min) to room temperature to lock in the smectic LC morphology without inducing thermal stress.

“

*Self-Validation Check: Perform Polarized Optical Microscopy (POM) equipped with a hot stage on a thin-film sample of the cured resin. The appearance of a distinct focal-conic or fan-shaped texture confirms the successful self-assembly of the highly ordered smectic phase[3].*

## Protocol C: Fabrication of High-k Microelectronic Encapsulants

To bridge the gap from  $\sim 0.3$  W/m·K to the  $>0.6$  W/m·K required for advanced microelectronic or biomedical encapsulation, inorganic fillers must be integrated[1].

Step-by-Step Methodology:

- Filler Functionalization: Treat hexagonal boron nitride (h-BN) microparticles with 3-aminopropyltriethoxysilane (APTES) to functionalize the surface with primary amines. This ensures covalent integration into the epoxy network.
- Dispersion: Disperse 5.0 wt% of the functionalized h-BN into the DGETP melt using high-shear mixing and ultrasonication for 30 minutes at 150°C.

- Curing: Proceed with the addition of m-PDA and the step-cure cycle outlined in Protocol B.

“

*Self-Validation Check: Measure the bulk thermal conductivity of the composite using the laser flash method (ASTM E1461). A value  $\geq 0.6$  W/m·K confirms proper filler dispersion and the synergistic effect of the LC matrix bridging the h-BN particles[1].*

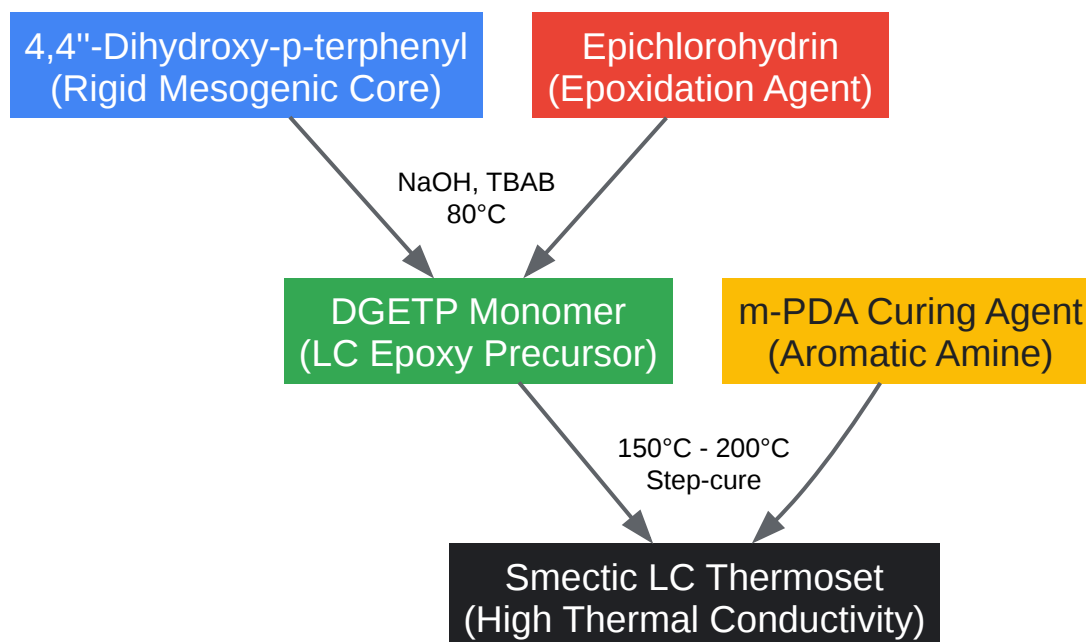

[Click to download full resolution via product page](#)

Caption: Workflow for the synthesis and curing of DGETP-based liquid crystalline epoxy resins.

## References

- Thermal Conductivity and Orientation Structure of Liquid Crystalline Epoxy Thermosets Prepared by Latent Curing Catalyst Source: MDPI (Polymers) URL:[[Link](#)]
- Acid Resistant Liquid Crystalline Epoxy Resins Source: Advanced Science News / Journal of Applied Polymer Science URL:[[Link](#)]

- Preparation and Thermomechanical Properties of Ketone Mesogenic Liquid Crystalline Epoxy Resin Composites with Functionalized Boron Nitride Source: PMC - National Institutes of Health (NIH) URL:[[Link](#)]

#### Need Custom Synthesis?

BenchChem offers custom synthesis for rare earth carbides and specific isotopic labeling.

Email: [info@benchchem.com](mailto:info@benchchem.com) or [Request Quote Online](#).

## Sources

- 1. Preparation and Thermomechanical Properties of Ketone Mesogenic Liquid Crystalline Epoxy Resin Composites with Functionalized Boron Nitride - PMC [[pmc.ncbi.nlm.nih.gov](https://pubmed.ncbi.nlm.nih.gov)]
- 2. Acid Resistant Liquid Crystalline Epoxy Resins [[advancedsciencenews.com](https://www.advancedsciencenews.com)]
- 3. Thermal Conductivity and Orientation Structure of Liquid Crystalline Epoxy Thermosets Prepared by Latent Curing Catalyst | MDPI [[mdpi.com](https://www.mdpi.com)]
- To cite this document: BenchChem. [Application Note: High-Performance Terphenyl-Based Liquid Crystalline Epoxy Resins]. BenchChem, [2026]. [Online PDF]. Available at: [<https://www.benchchem.com/product/b3041907/docs#application-note-high-performance-terphenyl-based-liquid-crystalline-epoxy-resins>]

### Disclaimer & Data Validity:

The information provided in this document is for Research Use Only (RUO) and is strictly not intended for diagnostic or therapeutic procedures. While BenchChem strives to provide accurate protocols, we make no warranties, express or implied, regarding the fitness of this product for every specific experimental setup.

**Technical Support:** The protocols provided are for reference purposes. Unsure if this reagent suits your experiment?

**Need Industrial/Bulk Grade?** [Request Custom Synthesis Quote](#)

# BenchChem

Our mission is to be the trusted global source of essential and advanced chemicals, empowering scientists and researchers to drive progress in science and industry.

## Contact

Address: 3281 E Guasti Rd

Ontario, CA 91761, United States

Phone: (601) 213-4426

Email: [info@benchchem.com](mailto:info@benchchem.com)

[Contact our Ph.D. Support Team for a compatibility check](#)