

Comparative kinase selectivity profile of quinoline scaffolds

Author: BenchChem Technical Support Team. **Date:** April 2026

Compound of Interest

Compound Name: 4-Piperazin-1-yl-7-(trifluoromethyl)quinoline
CAS No.: 104668-02-2
Cat. No.: B3039416

[Get Quote](#)

Comparative Kinase Selectivity Profile of Quinoline Scaffolds

Executive Summary: The Quinoline Advantage

The quinoline scaffold (benzo[b]pyridine) represents one of the most privileged structures in kinase inhibitor discovery. Unlike the ubiquitous quinazoline core (found in Gefitinib/Erlotinib) which predominantly targets EGFR via Type I binding, quinoline derivatives exhibit a remarkable plasticity in binding modes (Type I, II, IV, and V).[1] This structural versatility allows for the engineering of inhibitors with distinct selectivity profiles—ranging from narrow-spectrum covalent inhibitors to multi-targeted angiokinase inhibitors.

This guide provides a technical comparison of key quinoline-based scaffolds, dissecting how specific substitutions at the 3-, 4-, and 6-positions dictate kinase selectivity, binding kinetics, and therapeutic utility.[1]

Structural Classification & Selectivity Logic

The selectivity of quinoline inhibitors is largely governed by the linker at the 4-position (Anilino vs. Phenoxy) and the functional group at the 3-position (Carbonitrile vs. Carboxamide).

Class A: 4-Anilinoquinoline-3-carbonitriles (The "Dual-Src/Abl" & "Pan-HER" Class)[1]

- Core Logic: The 4-anilino group mimics the adenine of ATP, forming hydrogen bonds with the hinge region. The 3-carbonitrile group projects into the hydrophobic pocket, often interacting with the "gatekeeper" residue (e.g., T338 in Src, T315 in Abl).[1]
- Representative Compounds:
 - Bosutinib: A dual Src/Abl inhibitor.[1][2] Uniquely, it binds the active (DFG-in) conformation but possesses "Type II-like" selectivity features due to the nitrile group's interaction with the gatekeeper, allowing it to bypass certain resistance mutations (though not T315I).[1]
 - Neratinib: A covalent Pan-HER inhibitor.[1] It features a Michael acceptor (acrylamide) at the 6-position, allowing irreversible covalent bonding to Cys797 (EGFR) or Cys805 (HER2).[1]

Class B: 4-Phenoxyquinoline-6-carboxamides (The "Angiokinase" Class)[1]

- Core Logic: The switch from 4-anilino to 4-phenoxy alters the vector of the inhibitor, often pushing the molecule deeper into the hydrophobic back pocket or solvent front. The 6-carboxamide extension facilitates interactions with the DFG motif and allosteric regions.
- Representative Compounds:
 - Lenvatinib: A Type V inhibitor.[1][3] It binds the ATP site (DFG-in) but simultaneously occupies a neighboring allosteric region via its cyclopropane-urea moiety.[1] This unique mode confers high potency against VEGFRs and FGFRs with rapid association kinetics.[1]
 - Cabozantinib: A MET/VEGFR2 inhibitor.[1] It occupies the ATP pocket and extends into the deep hydrophobic pocket, effectively inhibiting MET (a difficult target for many Type I inhibitors).

Comparative Selectivity Data

The following table synthesizes inhibitory potency (

or

) against critical oncogenic drivers. Note the distinct "fingerprint" of each scaffold.

Compound	Scaffold Sub-Type	Binding Mode	Primary Targets (/ nM)	Key Off-Targets	Selectivity Profile
Bosutinib	4-Anilino-3-CN	Type I (Versatile)	Src (1.2), Abl (1.[1]0)	CAMK2G, TEC, STE20	Dual Src/Abl. High selectivity against PDGFR/KIT (unlike Imatinib).[1]
Neratinib	4-Anilino-3-CN	Irreversible (Covalent)	HER2 (59), EGFR (92)	MAPK pathway (weak)	Pan-HER. Potent against T790M resistance mutation due to covalent lock.[1]
Pelitinib	3-Cyanoquinoline	Irreversible (Covalent)	EGFR (39)	Src (weak)	EGFR-Selective. Early generation covalent inhibitor.[1]
Lenvatinib	4-Phenoxy-6-carboxamide	Type V (Allosteric-like)	VEGFR2 (0.74), FGFR1 (22)	RET, KIT, PDGFR	Multi-Kinase (Angio). Unique Type V mode yields rapid on-rate/slow off-rate (long residence time).[1]

Cabozantinib	4-Phenoxy-6-carboxamide	Type II (DFG-out)	MET (1.3), VEGFR2 (0.035)	AXL, RET, KIT	MET/VEGFR. Rare profile targeting MET and AXL simultaneously (overcoming resistance). [1]
--------------	-------------------------	-------------------	---------------------------	---------------	---

“

Data Source: Aggregated from Karaman et al. (Nat Biotech 2008), Davis et al. (Nat Biotech 2011), and FDA Pharmacology Reviews.[1] Values represent biochemical potencies and may vary by assay condition (e.g., ATP concentration).[1][4]

Visualizing the Scaffold-Selectivity Relationship

The following diagram illustrates how structural modifications to the Quinoline core divert the pharmacological activity toward specific kinase families.

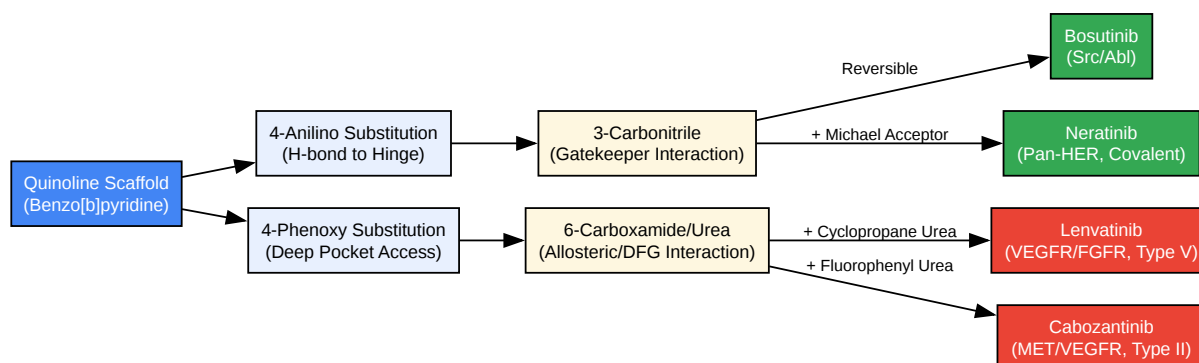

[Click to download full resolution via product page](#)

Figure 1: Structural Activity Relationship (SAR) flow of Quinoline Kinase Inhibitors.[1] Blue nodes represent the core scaffold, yellow nodes represent key substitutions, and green/red nodes represent final drug classes.

Experimental Protocol: Radiometric Kinase Profiling

To objectively verify the selectivity profiles described above, the Radiometric Filter Binding Assay is the gold standard. Unlike fluorescence-based assays (FRET/TR-FRET), this method is free from interference by fluorescent compounds and provides a direct measure of catalytic activity.[1]

Methodology: P-ATP HotSpot Assay

Objective: Determine the

of a quinoline test compound against a panel of kinases (e.g., EGFR, Src, MET).

Reagents:

- Kinase Buffer: 20 mM HEPES (pH 7.5), 10 mM MgCl₂, 1 mM EGTA, 0.02% Brij-35, 0.02 mg/mL BSA, 0.1 mM NaVO₂, 2 mM DTT.[1]
- Substrate: Specific peptide/protein substrate for the target kinase (e.g., Poly(Glu,Tyr) 4:1 for Src/Abl).[1]
- ATP Mix: Cold ATP + ³²P-ATP (Specific activity ~ 10 Ci/μmol) [1]

- Reaction Termination: 0.75% Phosphoric acid.[\[1\]](#)

Protocol Steps:

- Compound Preparation:
 - Prepare 100X stock of the quinoline inhibitor in 100% DMSO.
 - Perform serial dilutions (e.g., 3-fold) to generate a 10-point dose-response curve.[\[1\]](#)
 - Dispense 20 nL of compound into a 384-well plate (Acoustic dispensing preferred).
- Enzyme/Substrate Addition:
 - Dilute the specific Kinase and Substrate in Kinase Buffer.
 - Add 10

L of the Enzyme/Substrate mixture to the wells.
 - Critical Control: Include "No Enzyme" (background) and "No Inhibitor" (Max Signal) wells.
[\[1\]](#)
- Reaction Initiation:
 - Add 10

L of ATP Mix.
 - Note: The final ATP concentration should equal the

of the specific kinase to ensure competitive conditions.
- Incubation:
 - Incubate at Room Temperature for 2 hours. (Time linearity must be pre-validated).
- Termination & Detection:

- Spot the reaction mixture onto P81 phosphocellulose filter paper (binds cationic peptides).
[1]
- Wash filters 3x with 0.75% Phosphoric acid (removes unbound ATP).[1]
- Wash 1x with Acetone (drying).[1]
- Measure radioactivity using a scintillation counter or phosphorimager.[1]
- Data Analysis:
 - Calculate % Enzyme Activity relative to DMSO controls.[1]
 - Fit data to the Hill equation:
[1]

Workflow Visualization

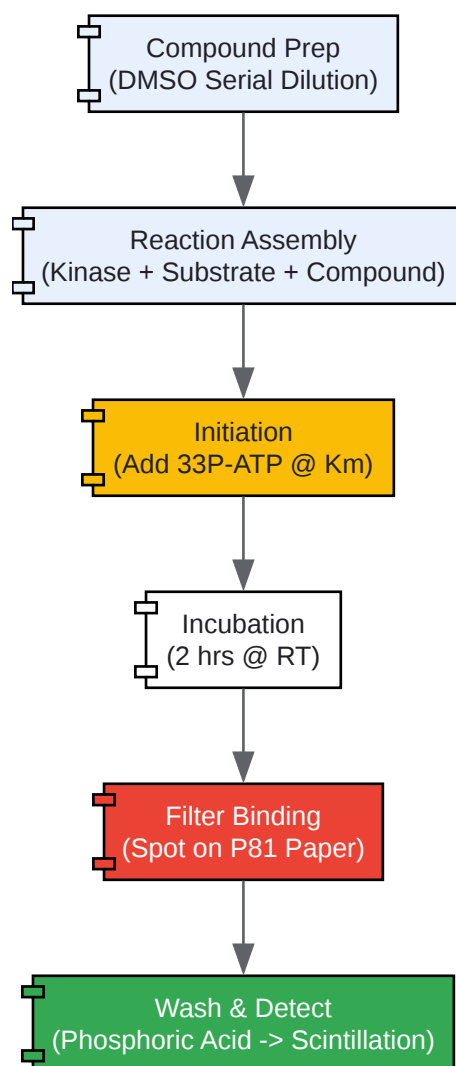

[Click to download full resolution via product page](#)

Figure 2: Step-by-step workflow for the Radiometric

P-ATP Kinase Assay.

References

- Bosutinib Binding Mode & Selectivity: Remsing Rix, L. L., et al. (2009).[1] "Global target profile of the kinase inhibitor bosutinib in primary chronic myeloid leukemia cells." *Leukemia*, 23(3), 477–485.[1] [Link](#)
- Lenvatinib Type V Mechanism: Okamoto, K., et al. (2015).[1][3] "Distinct Binding Mode of Multikinase Inhibitor Lenvatinib Revealed by Biochemical Characterization." *ACS Medicinal Chemistry Letters*, 6(1), 89–94.[1] [Link](#)[1]

- Comprehensive Kinase Profiling Data: Davis, M. I., et al. (2011).[1] "Comprehensive analysis of kinase inhibitor selectivity." *Nature Biotechnology*, 29, 1046–1051.[1] [Link](#)[1]
- Cabozantinib Profile: Yakes, F. M., et al. (2011).[1] "Cabozantinib (XL184), a novel MET and VEGFR2 inhibitor, simultaneously suppresses metastasis, angiogenesis, and tumor growth." [1] *Molecular Cancer Therapeutics*, 10(12), 2298-2308.[1] [Link](#)
- Radiometric Assay Methodology: Hastie, C. J., et al. (2006).[1] "Assay of protein kinases using radiolabeled ATP: a protocol." *Nature Protocols*, 1, 968–971.[1] [Link](#)

Need Custom Synthesis?

BenchChem offers custom synthesis for rare earth carbides and specific isotopic labeling.

Email: info@benchchem.com or [Request Quote Online](#).

Sources

- 1. Lenvatinib - Wikipedia [en.wikipedia.org]
- 2. ClinPGx [clintpgx.org]
- 3. Lenvatinib: a Receptor Tyrosine Kinase Inhibitor | Value-Based Cancer Care [valuebasedcancer.com]
- 4. carnabio.com [carnabio.com]
- To cite this document: BenchChem. [Comparative kinase selectivity profile of quinoline scaffolds]. BenchChem, [2026]. [Online PDF]. Available at: [<https://www.benchchem.com/product/b3039416/docs#comparative-kinase-selectivity-profile-of-quinoline-scaffolds>]

Disclaimer & Data Validity:

The information provided in this document is for Research Use Only (RUO) and is strictly not intended for diagnostic or therapeutic procedures. While BenchChem strives to provide accurate protocols, we make no warranties, express or implied, regarding the fitness of this product for every specific experimental setup.

Technical Support: The protocols provided are for reference purposes. Unsure if this reagent suits your experiment?

Need Industrial/Bulk Grade? [Request Custom Synthesis Quote](#)

BenchChem

Our mission is to be the trusted global source of essential and advanced chemicals, empowering scientists and researchers to drive progress in science and industry.

Contact

Address: 3281 E Guasti Rd
Ontario, CA 91761, United States
Phone: (601) 213-4426
Email: info@benchchem.com

[Contact our Ph.D. Support Team for a compatibility check](#)