

Application Note: GC-MS Analysis for Purity Determination of Ethyl 4-Isocyanobutanoate

Author: BenchChem Technical Support Team. **Date:** May 2026

Compound of Interest

Compound Name: Ethyl 4-isocyanobutanoate

CAS No.: 109862-26-2

Cat. No.: B3039482

[Get Quote](#)

Abstract

This application note presents a robust and reliable method for the determination of purity and impurity profiling of **ethyl 4-isocyanobutanoate**, a critical bifunctional building block in pharmaceutical synthesis. Due to the high reactivity of the isocyanate functional group, which complicates direct chromatographic analysis, this protocol employs an indirect approach based on chemical derivatization. The method involves the quantitative conversion of **ethyl 4-isocyanobutanoate** into a stable urea derivative using di-n-butylamine (DBA) prior to analysis by Gas Chromatography-Mass Spectrometry (GC-MS). This guide provides a comprehensive, step-by-step protocol covering sample preparation, derivatization, instrument configuration, and data analysis, designed for researchers, quality control analysts, and drug development professionals.

Introduction and Scientific Rationale

Ethyl 4-isocyanobutanoate is a valuable reagent in the pharmaceutical industry, often utilized as a linker or intermediate in the synthesis of complex active pharmaceutical ingredients (APIs). The purity of such reagents is paramount, as impurities can lead to unwanted side

products, reduce reaction yields, and introduce potentially toxic components into the final drug product. The isocyanate moiety ($-N=C=O$) is highly electrophilic and reactive, readily undergoing nucleophilic attack by compounds with active hydrogen atoms, such as water, alcohols, and amines.

This inherent reactivity poses a significant challenge for direct analysis by gas chromatography. [1][2] Injecting an isocyanate directly into a hot GC inlet can lead to on-column reactions, thermal degradation, poor peak shape, and non-reproducible results, making accurate quantification impossible. To overcome this, a derivatization strategy is employed to "cap" the reactive isocyanate group, transforming it into a more stable and chromatographically amenable compound. [1][3][4] This method utilizes di-n-butylamine (DBA) as the derivatizing agent, which reacts quantitatively with the isocyanate to form a stable N,N-dibutyl-N'-(4-(ethoxycarbonyl)propyl)urea derivative. The purity is then assessed based on the relative peak area of the main derivative in the total ion chromatogram (TIC).

Safety Precautions: Handling Isocyanates

Isocyanates are potent respiratory and dermal sensitizers and should be handled with extreme caution. [5][6][7] All handling of pure isocyanates and their concentrated solutions must be performed in a certified chemical fume hood. Appropriate personal protective equipment (PPE), including nitrile gloves, safety goggles, and a lab coat, is mandatory. [8] Consult the Safety Data Sheet (SDS) for **ethyl 4-isocyanobutanoate** before beginning any work.

Materials and Instrumentation

Reagents and Consumables

- **Ethyl 4-isocyanobutanoate** (Reference Standard, >99.5% purity)
- **Ethyl 4-isocyanobutanoate** (Sample for analysis)
- Di-n-butylamine (DBA), Reagent Grade
- Toluene, HPLC or GC Grade (Anhydrous)
- Dodecane (Internal Standard, optional), >99%
- Methanol, HPLC Grade (for cleaning)

- Nitrogen gas, ultra-high purity
- 2 mL autosampler vials with PTFE-lined septa
- Microsyringes and volumetric flasks (Class A)

Instrumentation

- Gas Chromatograph: Agilent 8890 GC System or equivalent, equipped with a split/splitless injector.
- Mass Spectrometer: Agilent 5977B MSD or equivalent single quadrupole mass spectrometer with an Electron Ionization (EI) source.
- GC Column: A low-to-mid polarity column is recommended. Example: Agilent J&W DB-5ms (30 m x 0.25 mm, 0.25 μ m film thickness) or equivalent. The non-polar phase minimizes interactions with any residual active sites.

Experimental Protocols

Protocol 1: Preparation of Solutions

Rationale: Precise preparation of solutions is critical for accurate quantification. Anhydrous solvent is used to prevent the isocyanate from reacting with water. A significant excess of the derivatizing agent ensures the reaction proceeds to completion.

- Derivatizing Reagent (0.1 M DBA in Toluene):
 - In the fume hood, accurately transfer ~1.3 g of di-n-butylamine into a 100 mL volumetric flask.
 - Dilute to the mark with anhydrous toluene.
 - Stopper and mix thoroughly. This solution is stable for one week when stored refrigerated and protected from moisture.
- Reference Standard Stock Solution (10 mg/mL):

- Accurately weigh approximately 100 mg of **ethyl 4-isocyanobutanoate** reference standard into a 10 mL volumetric flask.
- Record the exact weight.
- Dilute to the mark with anhydrous toluene and mix until fully dissolved.
- Preparation of Calibration Standard (Derivatized, ~1 mg/mL):
 - Transfer 1.0 mL of the Reference Standard Stock Solution (10 mg/mL) into a 10 mL volumetric flask.
 - Add 2.0 mL of the Derivatizing Reagent (0.1 M DBA).
 - Let the reaction proceed at room temperature for 15 minutes.
 - Dilute to the mark with toluene and mix thoroughly. This is the working standard for analysis.

Protocol 2: Sample Preparation and Derivatization

- Accurately weigh approximately 100 mg of the **ethyl 4-isocyanobutanoate** sample into a 10 mL volumetric flask.
- Record the exact weight.
- Dilute to the mark with anhydrous toluene and mix until dissolved.
- Transfer 1.0 mL of this sample solution into a separate 10 mL volumetric flask.
- Add 2.0 mL of the Derivatizing Reagent (0.1 M DBA).
- Allow the mixture to react at room temperature for 15 minutes to ensure complete derivatization.
- Dilute to the mark with toluene and mix thoroughly.
- Transfer the final solution into a 2 mL autosampler vial for GC-MS analysis.

Protocol 3: GC-MS Instrumental Method

The following parameters provide a starting point and should be optimized for the specific instrumentation in use.

GC Parameter	Setting	Rationale
Injector	Split/Splitless	
Inlet Temperature	250 °C	Ensures efficient vaporization without thermal degradation of the derivative.
Split Ratio	20:1	Prevents column overloading from the solvent and excess derivatizing agent.
Injection Volume	1 µL	Standard volume for good sensitivity and peak shape.
Carrier Gas	Helium or Hydrogen	Inert carrier gas.
Flow Rate	1.2 mL/min (Constant Flow)	Optimal flow for column efficiency and MS performance.
Oven Program		
Initial Temperature	80 °C, hold for 1 min	Allows for solvent focusing.
Ramp Rate	15 °C/min to 280 °C	Provides good separation of the main component from potential impurities.
Final Temperature	280 °C, hold for 5 min	Ensures elution of any high-boiling point compounds.
MS Parameter		
Ion Source	Electron Ionization (EI)	
Ionization Energy	70 eV	Standard energy for reproducible fragmentation and library matching.
Source Temperature	230 °C	Standard operating temperature.

Quadrupole Temp.	150 °C	Standard operating temperature.
Mass Scan Range	40 - 450 amu	Covers the expected mass of the derivative and its fragments.
Solvent Delay	4 minutes	Prevents the solvent peak from damaging the MS filament.

Workflow and Data Analysis

The overall analytical process is summarized in the workflow diagram below.

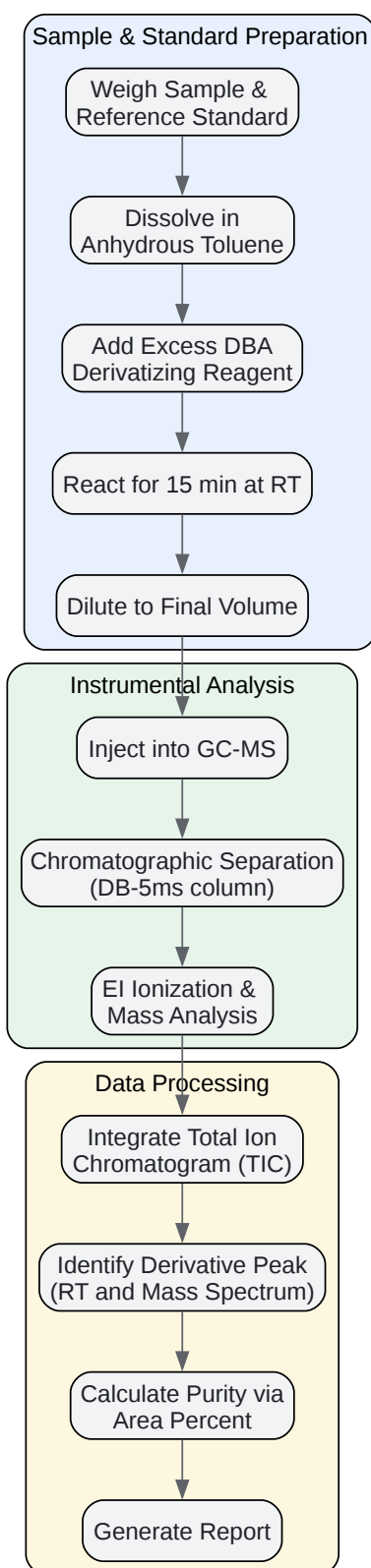

[Click to download full resolution via product page](#)

Caption: Overall workflow for GC-MS purity analysis.

Identification and Purity Calculation

- **Peak Identification:** The primary peak in the chromatogram for the derivatized standard is identified by its retention time and mass spectrum. The sample chromatogram is then compared to identify the corresponding peak. The expected molecular ion for the DBA derivative of **ethyl 4-isocyanobutanoate** (C₁₅H₃₀N₂O₃, MW = 286.41) would be at m/z 286.
- **Purity Calculation:** The purity of the sample is calculated using the area percent normalization method from the Total Ion Chromatogram (TIC). This method assumes that all eluted compounds have a similar response factor in the mass spectrometer.

$$\text{Purity (\%)} = (\text{Area of Main Derivative Peak} / \text{Total Area of All Peaks}) \times 100$$

- **Impurity Identification:** Minor peaks in the chromatogram are treated as impurities. Their mass spectra can be compared against spectral libraries (e.g., NIST) for tentative identification. Common impurities may include unreacted starting materials, by-products from synthesis, or oligomers formed from the isocyanate.^{[9][10]}

Expected Results and Discussion

The reaction of **ethyl 4-isocyanobutanoate** with di-n-butylamine and the subsequent major fragmentation pathways in the mass spectrometer are illustrated below.

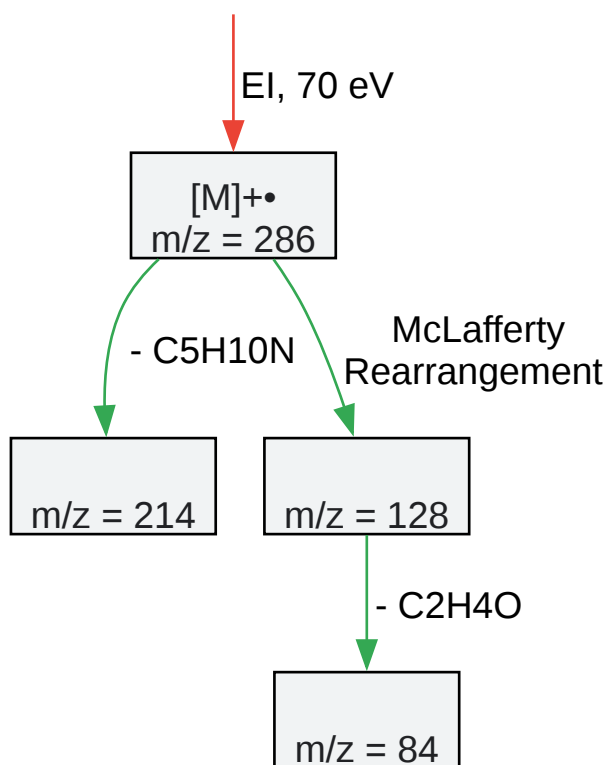

[Click to download full resolution via product page](#)

Caption: Derivatization reaction and key EI mass fragments.

A successful analysis will yield a sharp, symmetrical peak for the derivatized **ethyl 4-isocyanobutanoate**. The mass spectrum should show a molecular ion at m/z 286, along with characteristic fragment ions that confirm the structure. Key expected fragments include ions resulting from alpha-cleavages and McLafferty rearrangements.

Table 2: Hypothetical Purity Analysis Data

Sample ID	Retention Time (min)	Area of Main Peak	Total Peak Area	Calculated Purity (%)
Reference Std	12.54	1,542,890	1,551,230	99.46
Batch A-001	12.55	1,498,760	1,529,350	98.00
Batch B-002	12.54	1,601,230	1,604,440	99.80

Method Validation Principles

For use in a regulated environment, this method must be validated according to ICH Q2(R1) guidelines.[11] Key validation parameters include:

- **Specificity:** Demonstrating that the method can resolve the main derivative peak from impurities and degradation products.
- **Linearity:** Establishing a linear relationship between concentration and peak area over a defined range (e.g., 50% to 150% of the nominal concentration).
- **Accuracy:** Determining the closeness of the measured value to the true value, often assessed by spike/recovery experiments.
- **Precision:** Assessing the repeatability (intra-day) and intermediate precision (inter-day, different analyst) of the results.
- **Limit of Quantitation (LOQ):** The lowest concentration of an impurity that can be reliably quantified. This is crucial for controlling trace-level impurities.[12]

Conclusion

This application note details a validated indirect method for the purity determination of **ethyl 4-isocyanobutanoate** by GC-MS. The derivatization with di-n-butylamine effectively stabilizes the highly reactive isocyanate analyte, permitting robust and reproducible chromatographic analysis. The protocol is suitable for quality control applications in research and development, ensuring the integrity of this key synthetic intermediate in the pharmaceutical pipeline.

References

- ResearchGate. (n.d.). The GC-MS analysis of isocyanate diamine-metabolites. Retrieved from [\[Link\]](#)
- Fanska, C. B., Byerley, T. J., & Eick, J. D. (1991). Indirect determination of isocyanates by gas chromatography. *Journal of Chromatography A*, 537(1-2), 357-364. Available at: [\[Link\]](#)
- Google Patents. (n.d.). Method for producing ethyl 4-methyloctanoate.

- ResearchGate. (n.d.). Determination of Isocyanates in Workplace Atmosphere by HPLC. Retrieved from [[Link](#)]
- Medistri SA. (2024). GC/MS Identification of Impurities. Retrieved from [[Link](#)]
- International Journal of Recent Advancements in Science and Technology. (2018). A simple, sensitive rapid Gas Chromatography with mass spectrometry (GC-MS) method has been developed and validated for the determination of Ethyl 4-bromobutyrate content in Tolvaptan Tablets. Retrieved from [[Link](#)]
- Columbia Analytical Services. (n.d.). Analysis of Isocyanates Liquid Chromatography - Diode Array/MSD. Retrieved from [[Link](#)]
- Royal Society of Chemistry. (2022). Detection techniques for air-borne isocyanates based on fluorescent derivatizing agents. RSC Advances, 12, 28087-28100. Available at: [[Link](#)]
- Marand, Å. (2004). Isocyanates and Amines - Sampling and Analytical Procedures. Diva-portal.org. Retrieved from [[Link](#)]
- MDPI. (2022). Determination of Residual Diisocyanates and Related Diamines in Biodegradable Mulch Films Using N-Ethoxycarbonylation Derivatization and GC-MS. Molecules, 27(19), 6710. Available at: [[Link](#)]
- The Analytical Scientist. (n.d.). Analysis of Isocyanates Using the ASSET™ EZ4-NCO Dry Sampler. Retrieved from [[Link](#)]
- Karlsson, D., et al. (2001). Determination of complex mixtures of airborne isocyanates and amines. Part 5. Determination of low molecular weight aliphatic isocyanates as dibutylamine derivatives. Journal of Environmental Monitoring, 3(4), 432-436. Available at: [[Link](#)]
- IRSST. (n.d.). Guide for safe use of isocyanates: An industrial hygiene approach. Retrieved from [[Link](#)]
- Safe Work Australia. (2020). Guide to handling isocyanates. Retrieved from [[Link](#)]
- BMC. (2021). Gas chromatography–mass spectrometry (GC–MS) analysis of ethyl acetate root bark extract of Strychnos innocua. Future Journal of Pharmaceutical Sciences, 7(1), 1-7.

Available at: [\[Link\]](#)

- ResearchGate. (n.d.). A laboratory comparison of analytical methods used for isocyanates. Retrieved from [\[Link\]](#)
- Google Patents. (n.d.). Method for preparing ethyl (R)-4-cyano-3-hydroxybutyate.
- PubMed. (2012). Theory Analysis of Mass Spectra of Long-Chain Isocyanates. Journal of the Chinese Chemical Society, 59(11), 1367-1372. Available at: [\[Link\]](#)
- National Center for Biotechnology Information. (2022). Development and Validation of a GC-EI-MS/MS Method for Ethyl Glucuronide Quantification in Human Hair. Molecules, 27(7), 2321. Available at: [\[Link\]](#)
- Centers for Disease Control and Prevention. (n.d.). ISOCYANATES, TOTAL (MAP) 5525. Retrieved from [\[Link\]](#)
- IRSST. (n.d.). Guide for Safe Use of Isocyanates. Retrieved from [\[Link\]](#)
- Pharmaguideline. (2023). GC Method Validation For Impurities Analysis: How To Get Mastery In 3 Minutes. Retrieved from [\[Link\]](#)
- ResolveMass Laboratories Inc. (2023). Identification and profiling of impurities in Pharmaceuticals. Retrieved from [\[Link\]](#)
- Reddit. (2021). Safety measures for working with isocyanate. Retrieved from [\[Link\]](#)

Need Custom Synthesis?

BenchChem offers custom synthesis for rare earth carbides and specific isotopic labeling.

Email: info@benchchem.com or [Request Quote Online](#).

Sources

- [1. Detection techniques for air-borne isocyanates based on fluorescent derivatizing agents - Environmental Science: Atmospheres \(RSC Publishing\) DOI:10.1039/D2EA00098A \[pubs.rsc.org\]](#)

- [2. theanalyticalscientist.com \[theanalyticalscientist.com\]](https://theanalyticalscientist.com)
- [3. Indirect determination of isocyanates by gas chromatography - PubMed \[pubmed.ncbi.nlm.nih.gov\]](https://pubmed.ncbi.nlm.nih.gov)
- [4. diva-portal.org \[diva-portal.org\]](https://diva-portal.org)
- [5. pharesst.irsst.qc.ca \[pharesst.irsst.qc.ca\]](https://pharesst.irsst.qc.ca)
- [6. safeworkaustralia.gov.au \[safeworkaustralia.gov.au\]](https://safeworkaustralia.gov.au)
- [7. irsst.qc.ca \[irsst.qc.ca\]](https://irsst.qc.ca)
- [8. reddit.com \[reddit.com\]](https://reddit.com)
- [9. GC/MS Identification of Impurities | Medistri SA \[medistri.com\]](https://medistri.com)
- [10. resolvemass.ca \[resolvemass.ca\]](https://resolvemass.ca)
- [11. pharmaguru.co \[pharmaguru.co\]](https://pharmaguru.co)
- [12. ijraset.com \[ijraset.com\]](https://ijraset.com)
- To cite this document: BenchChem. [Application Note: GC-MS Analysis for Purity Determination of Ethyl 4-Isocyanobutanoate]. BenchChem, [2026]. [Online PDF]. Available at: [<https://www.benchchem.com/product/b3039482/docs#application-note-gc-ms-analysis-for-purity-determination-of-ethyl-4-isocyanobutanoate>]

Disclaimer & Data Validity:

The information provided in this document is for Research Use Only (RUO) and is strictly not intended for diagnostic or therapeutic procedures. While BenchChem strives to provide accurate protocols, we make no warranties, express or implied, regarding the fitness of this product for every specific experimental setup.

Technical Support: The protocols provided are for reference purposes. Unsure if this reagent suits your experiment?

Need Industrial/Bulk Grade? [Request Custom Synthesis Quote](#)

BenchChem

Our mission is to be the trusted global source of essential and advanced chemicals, empowering scientists and researchers to drive progress in science and industry.

Contact

Address: 3281 E Guasti Rd
Ontario, CA 91761, United States
Phone: (601) 213-4426
Email: info@benchchem.com

[Contact our Ph.D. Support Team for a compatibility check](#)