

Technical Support Center: Selective Demethylation in Dimethoxybenzaldehyde Derivatives

Author: BenchChem Technical Support Team. **Date:** May 2026

Compound of Interest

Compound Name:	<i>2-Bromo-4-fluoro-5-methoxybenzaldehyde</i>
CAS No.:	865186-62-5
Cat. No.:	B3038445

[Get Quote](#)

Welcome to the technical support center for researchers, scientists, and drug development professionals engaged in the selective demethylation of dimethoxybenzaldehyde derivatives. This guide is designed to provide in-depth, practical solutions to common challenges encountered during these sensitive transformations. We will move beyond simple protocols to explore the causality behind experimental choices, ensuring you can troubleshoot effectively and optimize your reactions for success.

Section 1: Foundational Principles & Frequently Asked Questions

This section addresses the fundamental concepts and common initial queries researchers have when approaching selective demethylation.

Q1: What are the primary factors governing the success and selectivity of a demethylation reaction on a dimethoxybenzaldehyde?

Answer: The outcome of a demethylation reaction is a delicate balance of electronic effects, steric hindrance, and reagent-substrate interactions. Three primary factors are at play:

- **Electronic Effects:** The methoxy group's position relative to the electron-withdrawing aldehyde group and the other methoxy group determines its electron density. Methoxy groups para to the aldehyde are generally more electron-rich and thus more susceptible to cleavage by electrophilic reagents like Lewis acids. Conversely, groups ortho to the aldehyde can be activated due to chelation effects with certain reagents.
- **Reagent Choice:** The mechanism of demethylation is dictated by the reagent. Lewis acids like Boron Tribromide (BBr_3) and Aluminum Chloride (AlCl_3) coordinate to the ether oxygen, activating it for cleavage.^{[1][2]} Brønsted acids like HBr or reagents like Pyridine Hydrochloride ($\text{Py}\cdot\text{HCl}$) require protonation of the ether, a step that often necessitates harsh, high-temperature conditions.^{[2][3]}
- **Chelation Control:** For substrates with an ortho-methoxy group (e.g., 2,3- or 2,4-dimethoxybenzaldehyde), reagents capable of forming a five- or six-membered chelate ring with the aldehyde oxygen and the ortho-methoxy oxygen can direct selective cleavage at that position. AlCl_3 is particularly known for this effect.^{[4][5]}

Q2: How do I select the most appropriate demethylating agent for my specific project?

Answer: Choosing the right reagent is critical and depends on your substrate's stability, the desired regioselectivity, and the available equipment. Use the following decision tree to guide your selection.

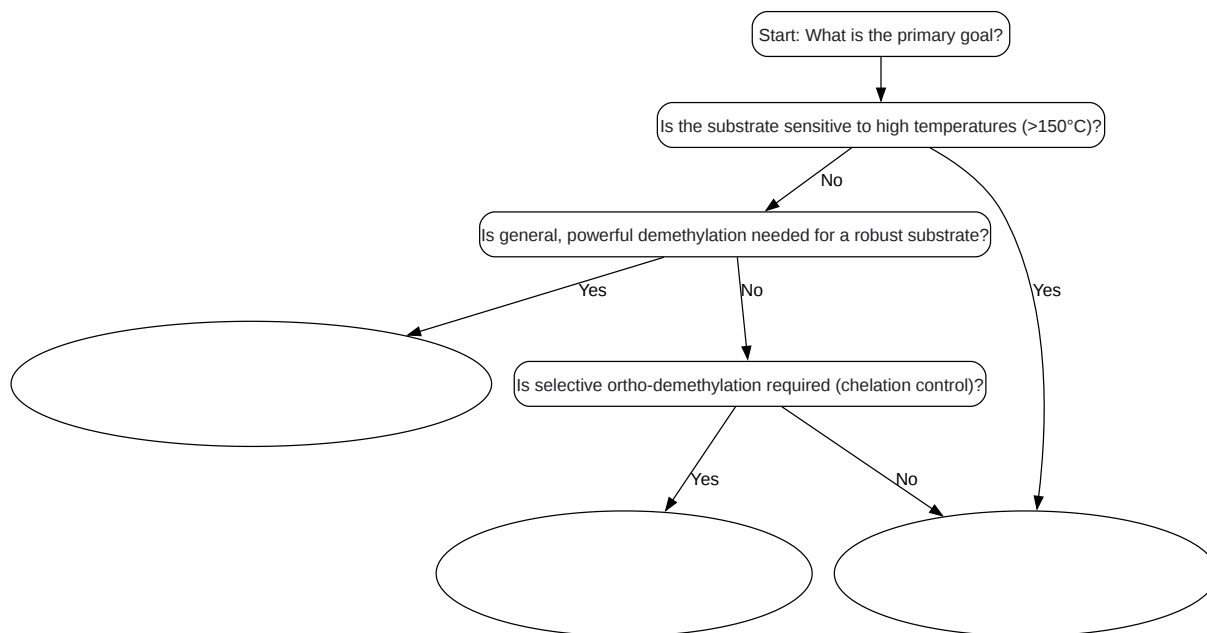

[Click to download full resolution via product page](#)

Caption: Decision tree for selecting a demethylation method.

Section 2: Troubleshooting Guide by Reagent

This section provides specific troubleshooting advice for the most common demethylating agents.

Boron Tribromide (BBr₃): The High-Reactivity Standard

BBr₃ is a powerful and versatile Lewis acid for ether cleavage, but its high reactivity demands careful handling.^[1]

Q: My BBr₃ reaction has a very low yield. What went wrong?

A: Low yields with BBr₃ are typically traced to two main issues: reagent deactivation and improper temperature control.

- **Moisture Contamination:** BBr₃ reacts violently with water and protic solvents.^{[1][6]} Ensure your glassware is oven-dried, your solvent (typically DCM) is anhydrous, and the reaction is run under an inert atmosphere (N₂ or Ar). Any moisture will consume the reagent, leading to incomplete conversion.
- **Temperature Protocol:** For selective monodemethylation, the reaction should be started at a very low temperature, such as -78°C (dry ice/acetone bath), with slow, dropwise addition of the BBr₃ solution.^[1] Adding the reagent too quickly or at a higher temperature can lead to the formation of intractable complexes or decomposition of the starting material. The reaction is then allowed to warm slowly to room temperature while monitoring by TLC.
- **Stoichiometry:** While older literature suggests a 3:1 ether:BBr₃ ratio, modern understanding of the mechanism shows one equivalent of BBr₃ can cleave up to three equivalents of an aryl methyl ether.^[7] However, for a complex substrate, starting with 1.1 to 1.5 equivalents of BBr₃ per methoxy group to be cleaved is a robust starting point.

Q: Upon adding BBr₃, a thick precipitate or agglomerate forms, and the reaction stalls. How can I solve this?

A: This is a common problem, especially with substrates that can form insoluble Lewis acid adducts.^[8]

- **Increase Solvent Volume:** The simplest solution is to increase the amount of dry solvent (e.g., DCM) to keep the intermediates in solution.
- **Slower Addition:** Add the BBr₃ solution very slowly at -78°C. This minimizes localized high concentrations of the reagent that can promote precipitation.

- Use $\text{BBr}_3 \cdot \text{SMe}_2$ Complex: The dimethyl sulfide complex of BBr_3 is a solid that is easier to handle and can sometimes exhibit more controlled reactivity, potentially reducing precipitation issues.

Q: My reaction is producing the di-hydroxy benzaldehyde instead of the mono-demethylated product. How can I improve selectivity?

A: Achieving monodemethylation requires precise control over stoichiometry and temperature.

- Reduce BBr_3 Equivalents: Carefully use only 1.0-1.2 equivalents of BBr_3 . A slight excess is often needed to drive the reaction to completion, but a large excess will favor complete demethylation.
- Maintain Low Temperature: Do not let the reaction warm for an extended period. Once the starting material is consumed (as judged by TLC), quench the reaction, even if it has not reached room temperature. For some substrates, holding the reaction at 0°C for a few hours is sufficient.
- Setup: To an oven-dried, three-neck round-bottom flask under a nitrogen atmosphere, add 3,4-dimethoxybenzaldehyde (1.0 eq) and anhydrous dichloromethane (DCM, ~ 0.1 M).
- Cooling: Cool the solution to -78°C using a dry ice/acetone bath.
- Reagent Addition: Slowly add a 1M solution of BBr_3 in DCM (1.1 eq) dropwise via syringe over 20-30 minutes.
- Reaction: Stir the mixture at -78°C for 1 hour, then allow it to slowly warm to room temperature over 3-4 hours. Monitor the reaction progress by TLC.
- Quenching: Once the starting material is consumed, cool the reaction to 0°C and very carefully quench by the slow, dropwise addition of methanol, followed by water. Caution: Quenching is highly exothermic.^[1]
- Workup: Transfer the mixture to a separatory funnel, dilute with more DCM, and wash sequentially with 1M HCl, water, and brine. Dry the organic layer over anhydrous Na_2SO_4 , filter, and concentrate under reduced pressure to obtain the crude product.

- Purification: Purify the residue by column chromatography on silica gel.

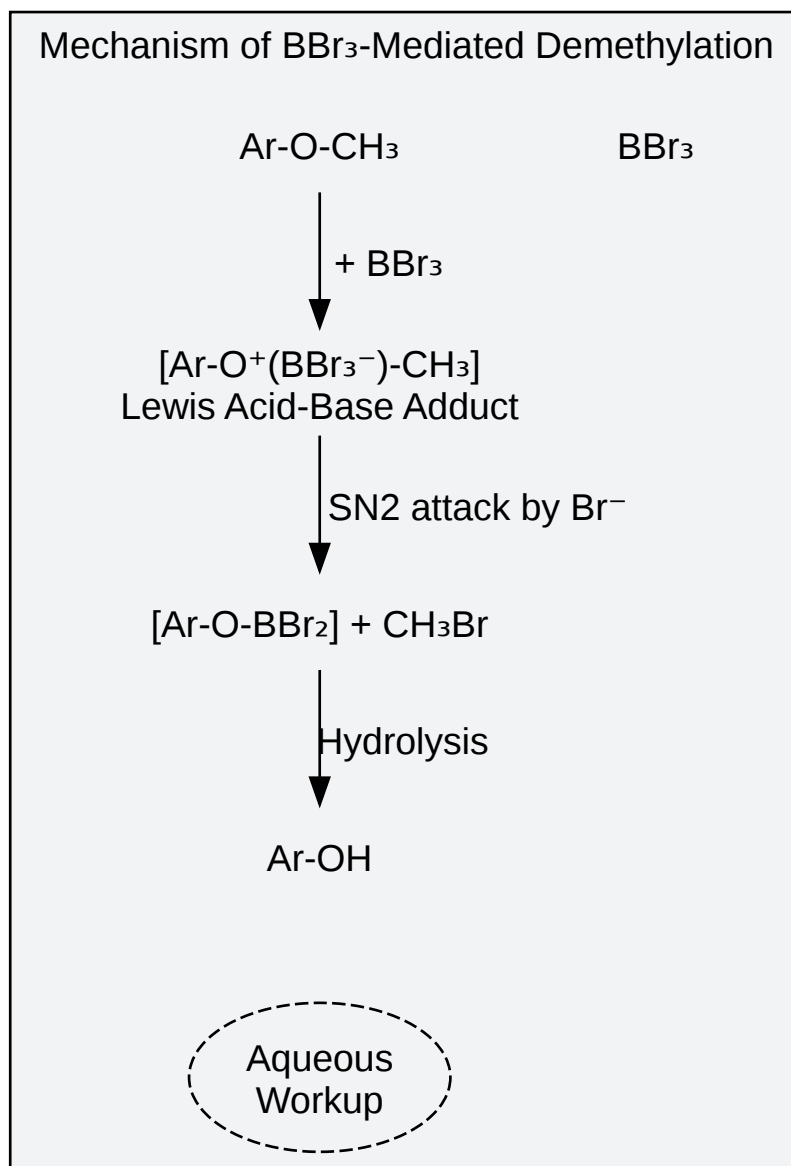

[Click to download full resolution via product page](#)

Caption: General mechanism for BBr₃-mediated ether cleavage.[1][7]

Aluminum Chloride (AlCl₃): The Chelation-Selective Choice

AlCl₃ is a milder Lewis acid than BBr₃ and is particularly useful for achieving regioselectivity through chelation with ortho-carbonyl groups.[1][4]

Q: My AlCl_3 -promoted reaction is not proceeding. What are the likely causes?

A: The activity of AlCl_3 is highly dependent on its quality and the reaction conditions.

- **Reagent Quality:** Anhydrous AlCl_3 is essential. It is highly hygroscopic and its surface can become inactivated by an oxidized film.^[1] It is best to use a freshly opened bottle or to grind the solid in a mortar just before use to expose a fresh surface.
- **Solvent Choice:** While DCM is common, reactions in acetonitrile have been reported to give good results.^[1] For some substrates, solvent-free conditions or the use of additives like sodium iodide or ethanethiol can significantly enhance reactivity.^{[1][9]}
- **Temperature:** Unlike BBr_3 , AlCl_3 reactions often require heating to proceed at a reasonable rate.^[1] Refluxing in DCM or acetonitrile is common.

Q: I am trying to demethylate 2,4-dimethoxybenzaldehyde. Which methoxy group will AlCl_3 cleave?

A: AlCl_3 will preferentially cleave the methoxy group ortho to the aldehyde. This is a classic example of chelation-directed demethylation. The aluminum coordinates to both the aldehyde oxygen and the oxygen of the C2-methoxy group, forming a stable six-membered ring. This coordination activates the C2-methoxy group for cleavage.^{[4][5]}

- **Setup:** To a flame-dried flask under an inert atmosphere, add the substituted dimethoxybenzaldehyde (1.0 eq) and anhydrous DCM.
- **Reagent Addition:** Cool the solution to 0°C and add anhydrous AlCl_3 (1.5-2.0 eq) portion-wise, controlling any exotherm.
- **Reaction:** Allow the reaction to stir at room temperature or heat to reflux, monitoring by TLC until the starting material is consumed.
- **Quenching:** Cool the reaction mixture to 0°C and slowly quench by adding 2M HCl.
- **Workup:** Extract the aqueous layer with ethyl acetate. Combine the organic layers, wash with water and brine, dry over anhydrous Na_2SO_4 , and concentrate in vacuo.

- Purification: Purify the product via silica gel chromatography.

Section 3: Substrate-Specific Troubleshooting

The substitution pattern on the benzaldehyde ring dramatically influences the reaction's outcome.

Case Study: 3,4-Dimethoxybenzaldehyde (Veratraldehyde)

- Challenge: The two methoxy groups have different electronic environments. The 4-methoxy is para to the aldehyde, while the 3-methoxy is meta.
- Expected Selectivity: Cleavage typically occurs at the more electron-rich 4-position, yielding vanillin (4-hydroxy-3-methoxybenzaldehyde). This is because the para-position receives more electron-donating resonance stabilization from the methoxy group, making its oxygen more Lewis basic.
- Troubleshooting: If you observe cleavage at the 3-position (isovanillin), it may be due to harsh, high-temperature conditions causing thermodynamic product formation or isomerization.^[10] Using milder conditions (e.g., BBr_3 at low temperature) strongly favors kinetic cleavage at the 4-position.

Case Study: 2,4-Dimethoxybenzaldehyde

- Challenge: Balancing chelation control versus electronic effects.
- Expected Selectivity: As discussed, Lewis acids like AlCl_3 will favor cleavage at the 2-position via chelation.^{[4][5]} Reagents that cannot chelate effectively might favor cleavage at the more electron-rich 4-position.
- Troubleshooting: A mixture of products indicates that the reaction conditions are not optimal for a single mechanism to dominate. To favor 2-demethylation, use a strong chelating Lewis acid like AlCl_3 . To favor 4-demethylation, a non-chelating system might be explored, although this is often less selective.

Section 4: Comparative Summary & Workflow

Reagent Comparison Table

Feature	Boron Tribromide (BBr ₃)	Aluminum Chloride (AlCl ₃)	Pyridine Hydrochloride (Py-HCl)
Reactivity	Very High[1]	Moderate[1]	Low (requires high temp)[3]
Conditions	-78°C to RT, Anhydrous[1]	0°C to Reflux, Anhydrous[4]	180-220°C or Microwave[3][11]
Selectivity	Generally favors most electron-rich site	High ortho-selectivity via chelation[4]	Often leads to complete demethylation
Advantages	Works for sensitive substrates, fast	Excellent for chelation control, cheaper	Inexpensive, simple reagent
Disadvantages	Highly toxic, moisture-sensitive, expensive[1]	Reagent quality is critical, can be sluggish	Harsh conditions, substrate degradation[3]

General Experimental Workflow

The following diagram outlines a typical workflow for a selective demethylation experiment, from initial planning to final analysis.

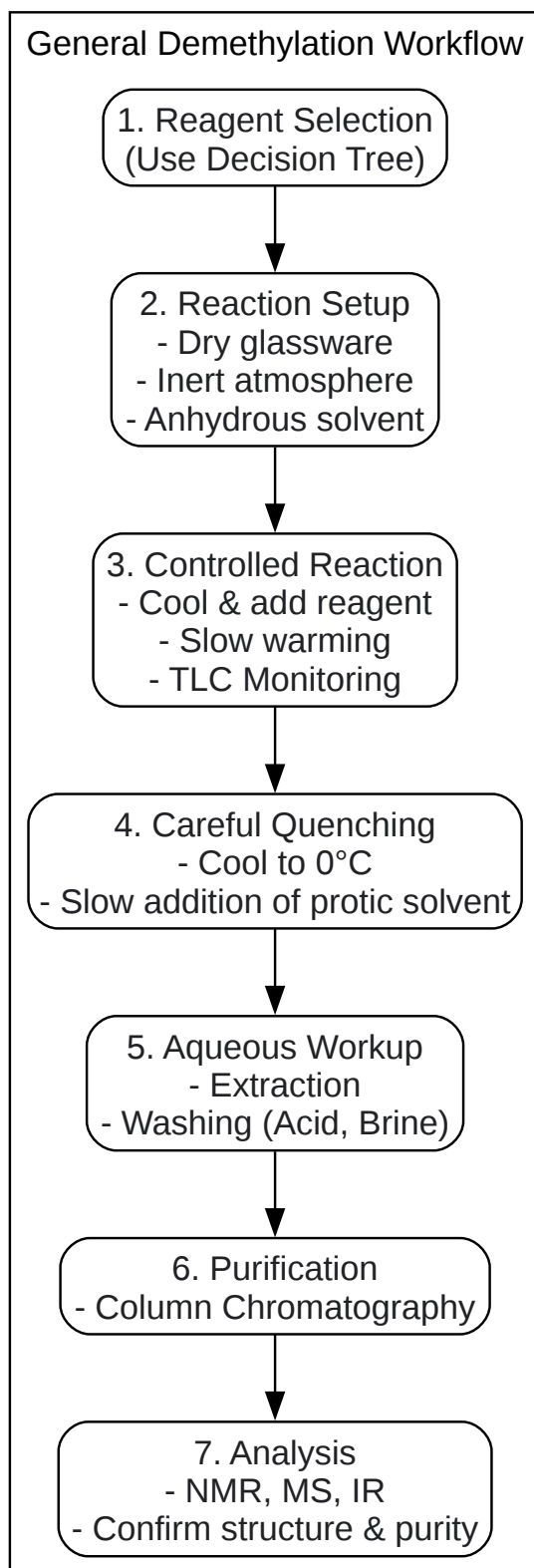

[Click to download full resolution via product page](#)

Caption: A standard workflow for demethylation experiments.

References

- Demethylation - Wikipedia. [\[Link\]](#)
- O-Demethylation | Chem-Station Int. Ed. [\[Link\]](#)
- (PDF) Pyridine hydrochloride in organic synthesis - ResearchGate. [\[Link\]](#)
- Efficient O-demethylation of lignin-derived aromatic compounds under moderate conditions. RSC Advances. [\[Link\]](#)
- Demethylation of Methyl Aryl Ethers using Pyridine Hydrochloride in Solvent-free Conditions under Microwave Irradiation - Journal of Chemical Research, Synopses (RSC Publishing). [\[Link\]](#)
- Demethylation of Methyl Aryl Ethers using Pyridine Hydrochloride in Solvent-free Conditions under Microwave Irradiation - RSC Publishing. [\[Link\]](#)
- Boron Tribromide - ResearchGate. [\[Link\]](#)
- Study of the ortho-methoxy substituent group effect in selective demethylation reactions of methoxybenzoic acids. - Blucher Proceedings. [\[Link\]](#)
- US20060052463A1 - Process for regioselective demethylation of p-methoxy group in phenolic ester and diaryl ketone moieties - Google P
- Modification of an Enzyme Biocatalyst for the Efficient and Selective Oxidative Demethylation of para-Substituted Benzene Deri - UQ eSpace. [\[Link\]](#)
- Demethylation of phenol methyl ether with ortho electron withdrawing groups by AlCl₃ - ResearchGate. [\[Link\]](#)
- ChemInform Abstract: A Facile Demethylation of ortho Substituted Aryl Methyl Ethers Promoted by AlCl₃. - ResearchGate. [\[Link\]](#)
- Ether Cleavage Re-Investigated: Elucidating the Mechanism of BBr₃-Facilitated Demethylation of Aryl Methyl Ethers - PMC. [\[Link\]](#)

- How to increase yield of Demethylation reaction using BBr₃? | ResearchGate. [[Link](#)]
- Selective demethylation reactions of biomass-derived aromatic ether polymers for bio-based lignin chemicals - Green Chemistry (RSC Publishing). [[Link](#)]
- Directed ortho metalation - Wikipedia. [[Link](#)]
- Selective demethylation reactions of biomass-derived aromatic ether polymers for bio-based lignin chemicals - ResearchGate. [[Link](#)]
- AlCl₃-Catalyzed Cascade Reactions of 1,2,3-Trimethoxybenzene and Adipoyl Chloride: Spectroscopic Investigations and Density Functional Theory Studies - PMC. [[Link](#)]
- Regioselectivity in the preparation of 2-hydroxy-4-methoxy benzaldehyde from resorcinol. [[Link](#)]
- Directed ortho-lithiation: observation of an unexpected 1-lithio to 3-lithio conversion of 1-lithio-naphthyllithium compounds with an ortho-directing 2-(dimethylamino)methyl group - PubMed. [[Link](#)]
- Directed (ortho) Metallation. [[Link](#)]
- CN102260132A - Demethylating reagent, method for removing methyl and method for preparing luciferin by use of demethylating reagent - Google P
- ortho metalation - Andrew G Myers Research Group. [[Link](#)]
- CN105777529A - Method for selective demethylation of ortho-trimethoxybenzene compounds - Google P
- Selective demethylation of the 5-methoxyl group in flavanones and synthesis of dihydrowogonin. [[Link](#)]
- Selective demethylation and debenylation of aryl ethers by magnesium iodide under solvent-free conditions and its application to the total synthesis of natural products - Organic & Biomolecular Chemistry (RSC Publishing). [[Link](#)]

- Directed ortho-metalation–nucleophilic acyl substitution strategies in deep eutectic solvents: the organolithium base dictates the chemoselectivity - Chemical Communications (RSC Publishing). [[Link](#)]

Need Custom Synthesis?

BenchChem offers custom synthesis for rare earth carbides and specific isotopic labeling.

Email: info@benchchem.com or [Request Quote Online](#).

Sources

- 1. O-Demethylation | Chem-Station Int. Ed. [en.chem-station.com]
- 2. Efficient O-demethylation of lignin-derived aromatic compounds under moderate conditions - PMC [pmc.ncbi.nlm.nih.gov]
- 3. Demethylation - Wikipedia [en.wikipedia.org]
- 4. researchgate.net [researchgate.net]
- 5. researchgate.net [researchgate.net]
- 6. researchgate.net [researchgate.net]
- 7. Ether Cleavage Re-Investigated: Elucidating the Mechanism of BBr₃-Facilitated Demethylation of Aryl Methyl Ethers - PMC [pmc.ncbi.nlm.nih.gov]
- 8. researchgate.net [researchgate.net]
- 9. CN102260132A - Demethylating reagent, method for removing methyl and method for preparing luciferin by use of demethylating reagent - Google Patents [patents.google.com]
- 10. pdf.benchchem.com [pdf.benchchem.com]
- 11. Demethylation of Methyl Aryl Ethers using Pyridine Hydrochloride in Solvent-free Conditions under Microwave Irradiation - Journal of Chemical Research, Synopses (RSC Publishing) [pubs.rsc.org]
- To cite this document: BenchChem. [Technical Support Center: Selective Demethylation in Dimethoxybenzaldehyde Derivatives]. BenchChem, [2026]. [Online PDF]. Available at: [<https://www.benchchem.com/product/b3038445/docs#technical-support-center-selective-demethylation-in-dimethoxybenzaldehyde-derivatives>]

Disclaimer & Data Validity:

The information provided in this document is for Research Use Only (RUO) and is strictly not intended for diagnostic or therapeutic procedures. While BenchChem strives to provide accurate protocols, we make no warranties, express or implied, regarding the fitness of this product for every specific experimental setup.

Technical Support: The protocols provided are for reference purposes. Unsure if this reagent suits your experiment?

Need Industrial/Bulk Grade? [Request Custom Synthesis Quote](#)

BenchChem

Our mission is to be the trusted global source of essential and advanced chemicals, empowering scientists and researchers to drive progress in science and industry.

Contact

Address: 3281 E Guasti Rd
Ontario, CA 91761, United States
Phone: (601) 213-4426
Email: info@benchchem.com

[Contact our Ph.D. Support Team for a compatibility check](#)