

# Application Notes and Protocols for Identifying CCR2-Expressing Cells via Flow Cytometry

**Author:** BenchChem Technical Support Team. **Date:** April 2026

## Compound of Interest

Compound Name:	CCR2-RA
CAS No.:	512177-31-0
Cat. No.:	B3037638

[Get Quote](#)

Audience: Researchers, scientists, and drug development professionals.

## Introduction

C-C chemokine receptor type 2 (CCR2) is a G protein-coupled receptor that plays a pivotal role in the migration of monocytes and other immune cells to sites of inflammation.<sup>[1][2]</sup> Its primary ligand is monocyte chemoattractant protein-1 (MCP-1), also known as CCL2.<sup>[3]</sup> The CCL2-CCR2 signaling axis is implicated in a variety of inflammatory and fibrotic diseases, as well as in cancer progression, making it a key target for therapeutic intervention.<sup>[3][4][5]</sup> Flow cytometry is a powerful technique for the identification and quantification of CCR2-expressing cells within heterogeneous populations, providing valuable insights into disease pathogenesis and the efficacy of novel therapeutics.

This document provides a detailed protocol for the identification of CCR2-expressing cells using flow cytometry, including sample preparation, staining procedures, and data analysis strategies.

## CCR2 Signaling Pathway

Upon binding its ligand, primarily CCL2, CCR2 activates several downstream signaling cascades, including the PI3K/Akt, MAPK/p38, and JAK/STAT pathways.[4][6][7] These pathways regulate a multitude of cellular processes such as cell survival, proliferation, migration, and cytokine production.[5][6]

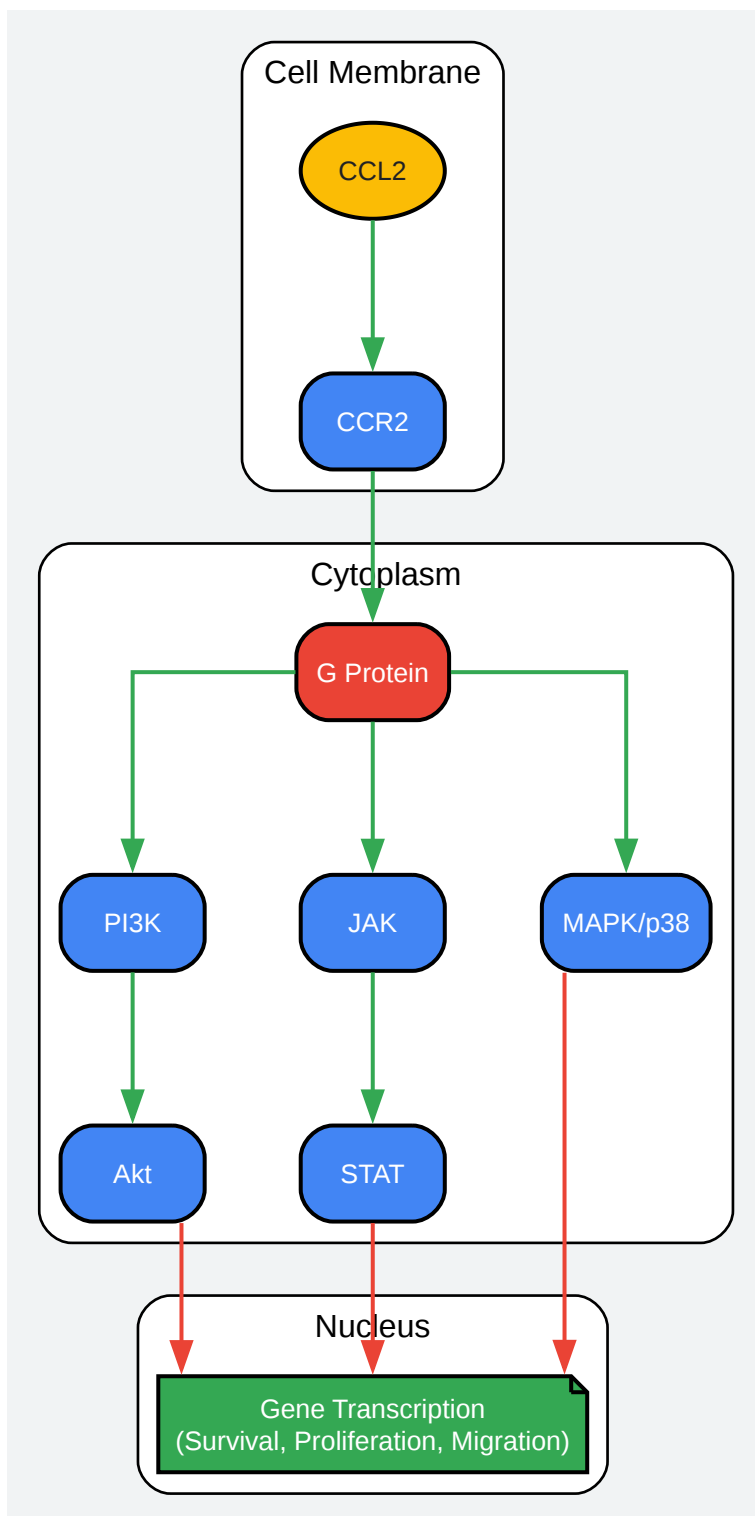

[Click to download full resolution via product page](#)

Caption: The CCR2 signaling pathway is initiated by CCL2 binding.

## Experimental Protocols

### Materials and Reagents

Reagent	Recommended Specification/Vendor
Primary Antibodies	See Table 1
Isotype Control	Match host and isotype of primary antibody
Staining Buffer	PBS with 1-2% BSA or FBS
Fixation Buffer	1-4% Paraformaldehyde (PFA) in PBS
Permeabilization Buffer	0.1-0.5% Saponin or Tween-20 in PBS
Red Blood Cell Lysis Buffer	e.g., BD Pharm Lyse™
Cell Viability Dye	e.g., 7-AAD, Propidium Iodide, or fixable viability dyes

### Table 1: Recommended Anti-Human CCR2 Antibodies for Flow Cytometry

Clone	Isotype	Conjugates	Vendor
LS132.1D9	Mouse IgG2a, κ	PE, and others	BD Biosciences[8]
8C3.1	Mouse Monoclonal	Unconjugated	Merck Millipore[9]
48607	Mouse Monoclonal	APC	R&D Systems[10]
7A7	Mouse Monoclonal	Unconjugated	OriGene[10]
9H6	Mouse Monoclonal	Unconjugated	OriGene[10]

Note: This is not an exhaustive list. Researchers should validate antibodies for their specific experimental conditions.

## Sample Preparation

A single-cell suspension is critical for successful flow cytometry. The optimal cell concentration is between  $1 \times 10^5$  and  $1 \times 10^7$  cells/mL.[\[11\]](#)

General Workflow for Sample Preparation:

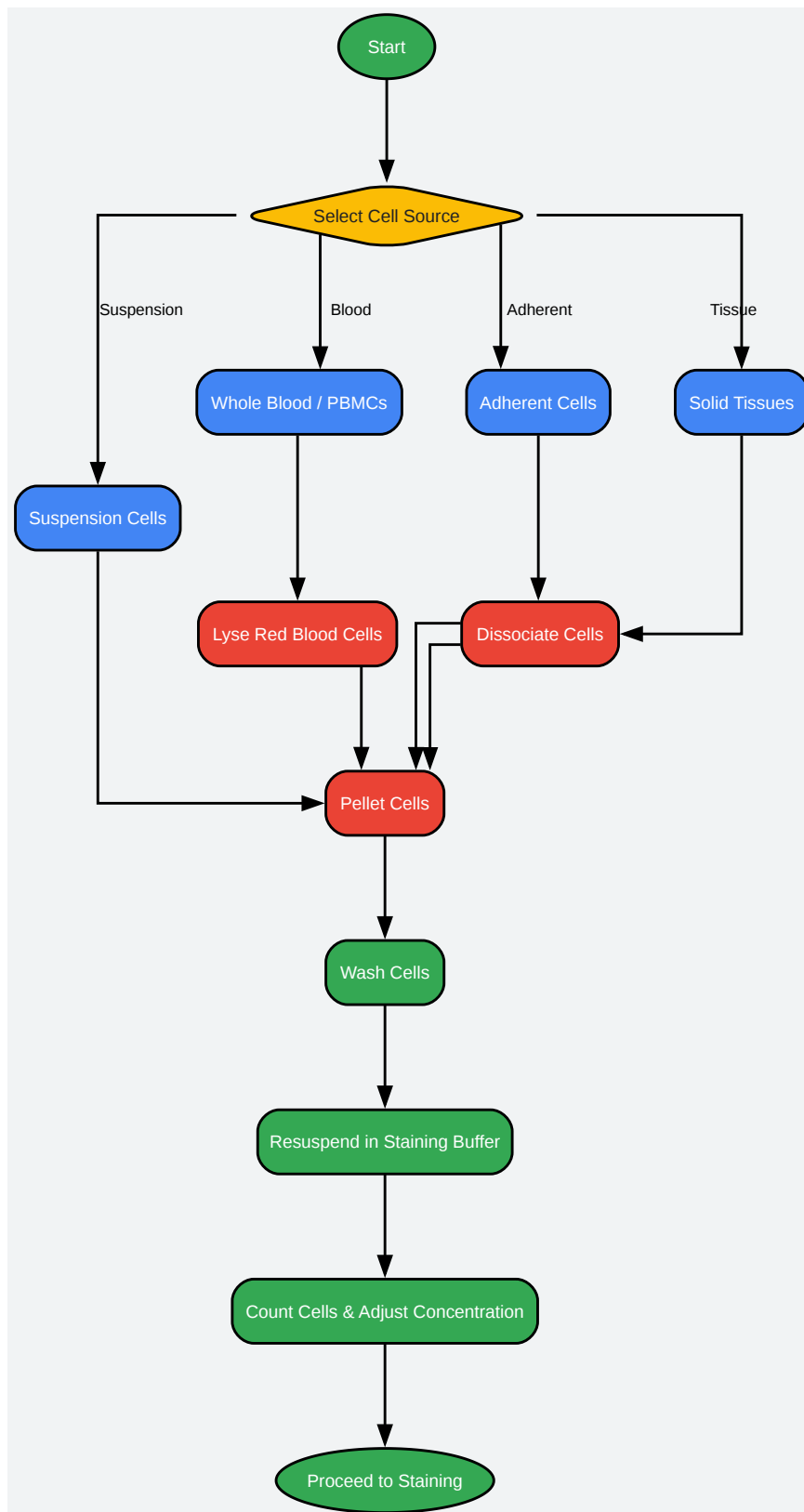

[Click to download full resolution via product page](#)

Caption: A generalized workflow for preparing single-cell suspensions.

## 2.1. Suspension Cells

- Transfer cells from the culture vessel to a centrifuge tube.
- Centrifuge at 300-400 x g for 5-10 minutes at room temperature.[12]
- Discard the supernatant and resuspend the cell pellet in cold staining buffer.[12]

## 2.2. Adherent Cells

- Gently wash cells with staining buffer. To preserve surface epitopes, avoid using trypsin. If necessary, use a gentler enzyme like Accutase or TrypLE Express.[13]
- Scrape the cells and transfer them to a centrifuge tube.
- Centrifuge at 400 RCF for 8 minutes.[13]
- Discard the supernatant and resuspend the cell pellet in cold staining buffer.

## 2.3. Whole Blood or Peripheral Blood Mononuclear Cells (PBMCs)

- For whole blood, perform red blood cell lysis according to the manufacturer's protocol.
- For PBMCs, isolate using Ficoll-Paque gradient centrifugation.
- Wash the cells with PBS by centrifuging at 300-400 x g for 10 minutes.[12]
- Resuspend the cell pellet in cold staining buffer.

## 2.4. Solid Tissues

- Mechanically or enzymatically dissociate the tissue to obtain a single-cell suspension.[11]
- Filter the cell suspension through a 40-70 µm cell strainer to remove clumps.
- Wash the cells with PBS and resuspend in staining buffer.

# Staining Protocol

### 3.1. Surface Staining

- Aliquot 100  $\mu\text{L}$  of the cell suspension (containing  $2 \times 10^5$  to  $1 \times 10^6$  cells) into flow cytometry tubes.[13]
- Add the predetermined optimal concentration of the anti-CCR2 antibody and any other surface marker antibodies.
- Incubate for 30 minutes at  $4^\circ\text{C}$  in the dark.
- Wash the cells twice with 1-2 mL of staining buffer, centrifuging at 400 RCF for 5 minutes after each wash.[13]
- If not proceeding to intracellular staining, resuspend the cells in 500  $\mu\text{L}$  of staining buffer for analysis.[13]

3.2. Intracellular Staining (if required) Note: Perform surface staining before intracellular staining as fixation and permeabilization can affect surface antigens.[13]

- After surface staining, fix the cells by adding 100  $\mu\text{L}$  of fixation buffer and incubating for 10-15 minutes at room temperature.[13]
- Wash the cells with staining buffer.
- Permeabilize the cells by adding 100  $\mu\text{L}$  of permeabilization buffer and incubating for 15 minutes at room temperature.[13]
- Wash the cells with permeabilization buffer.
- Add the intracellular antibody cocktail and incubate for 30-60 minutes at room temperature in the dark.[13]
- Wash the cells twice with permeabilization buffer.
- Resuspend the cells in 500  $\mu\text{L}$  of staining buffer for analysis.[13]

## Data Acquisition and Analysis

#### 4.1. Instrument Setup

- Set up appropriate voltage and compensation settings using single-stained controls.
- Use unstained cells to set the forward scatter (FSC) and side scatter (SSC) parameters.

#### 4.2. Gating Strategy

A sequential gating strategy is crucial for accurately identifying the CCR2-expressing cell population of interest.[\[14\]](#)

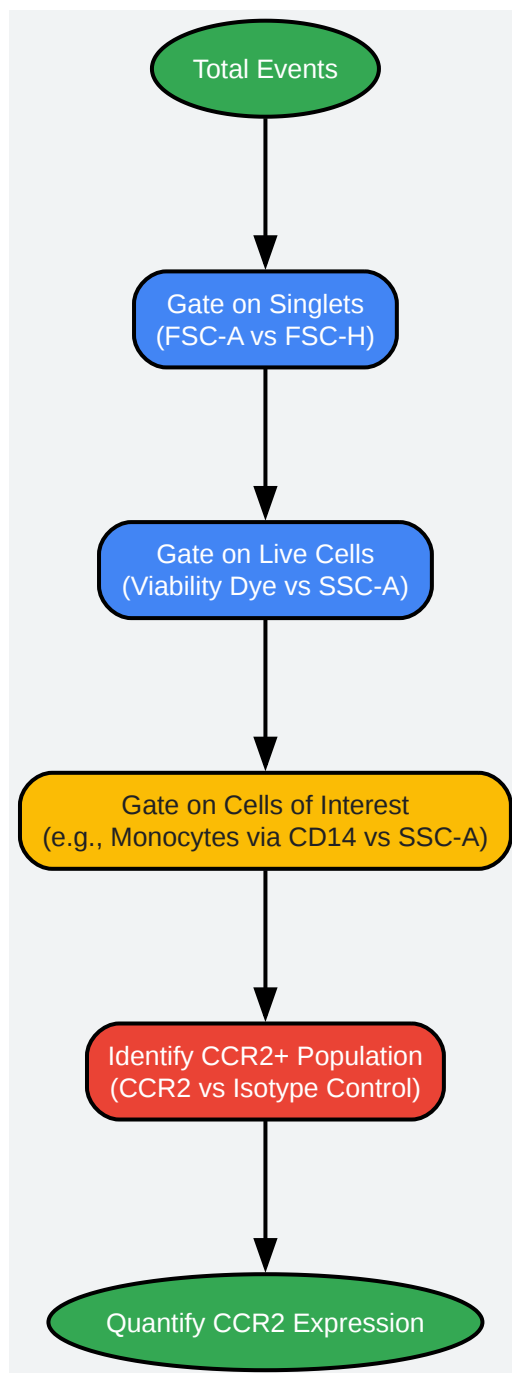

[Click to download full resolution via product page](#)

Caption: A typical gating strategy for identifying CCR2+ cells.

- Singlet Gate: Gate on single cells using FSC-A versus FSC-H to exclude doublets.
- Viability Gate: Gate on live cells using a viability dye to exclude dead cells, which can non-specifically bind antibodies.[14]

- Cell Population Gate: Identify the cell population of interest based on specific markers (e.g., CD14 for monocytes).[\[14\]](#)[\[15\]](#)
- CCR2+ Gate: Identify CCR2-positive cells by comparing the fluorescence intensity of the CCR2-stained sample to an isotype control.

## Data Presentation

Summarize all quantitative data into clearly structured tables for easy comparison.

**Table 2: Example Data Summary**

Sample ID	Cell Type	% CCR2+ of Parent Population	CCR2 MFI
Control 1	Monocytes	85.2	10,500
Control 2	Monocytes	88.1	11,200
Treated 1	Monocytes	45.6	5,300
Treated 2	Monocytes	42.9	5,150

MFI: Mean Fluorescence Intensity

## Troubleshooting

Issue	Possible Cause	Solution
Low CCR2 Signal	Poor antibody performance	Titrate antibody, try a different clone/fluorochrome.
Receptor internalization	Stain at 4°C to minimize internalization.[16][17]	
Low CCR2 expression on cell type	Confirm CCR2 expression on the target cell type from literature.	
High Background	Non-specific antibody binding	Use an Fc block, ensure proper washing steps.
Dead cells	Use a viability dye to exclude dead cells.	
Poor Cell Viability	Harsh sample preparation	Handle cells gently, use appropriate enzymes if needed.

By following these detailed protocols and application notes, researchers can reliably identify and quantify CCR2-expressing cells, contributing to a deeper understanding of their role in health and disease.

### Need Custom Synthesis?

BenchChem offers custom synthesis for rare earth carbides and specific isotopic labeling.

Email: [info@benchchem.com](mailto:info@benchchem.com) or [Request Quote Online](#).

## References

- 1. Role of CCR2 in inflammatory conditions of the central nervous system - PMC [[pmc.ncbi.nlm.nih.gov](https://pubmed.ncbi.nlm.nih.gov/)]
- 2. CCR2 Regulates the Immune Response by Modulating the Interconversion and Function of Effector and Regulatory T Cells - PubMed [[pubmed.ncbi.nlm.nih.gov](https://pubmed.ncbi.nlm.nih.gov/)]
- 3. [academic.oup.com](https://academic.oup.com/) [[academic.oup.com](https://academic.oup.com/)]

- 4. Role of the CCL2-CCR2 signalling axis in cancer: Mechanisms and therapeutic targeting - PMC [[pmc.ncbi.nlm.nih.gov](https://pubmed.ncbi.nlm.nih.gov)]
- 5. CCL2/CCR2 signaling pathway in tumorigenesis and metastasis (Review) - PMC [[pmc.ncbi.nlm.nih.gov](https://pubmed.ncbi.nlm.nih.gov)]
- 6. [researchgate.net](https://www.researchgate.net) [[researchgate.net](https://www.researchgate.net)]
- 7. Frontiers | Targeting the CCL2/CCR2 Axis in Cancer Immunotherapy: One Stone, Three Birds? [[frontiersin.org](https://www.frontiersin.org)]
- 8. PE Mouse Anti-Human CCR2 (CD192) [[bdbiosciences.com](https://wwwbdbiosciences.com)]
- 9. [merckmillipore.com](https://www.merckmillipore.com) [[merckmillipore.com](https://www.merckmillipore.com)]
- 10. CCR2 antibody | 27 products in Validated Antibody Database; 45 cited in the literature; 77 total from 15 suppliers [[labome.com](https://www.labome.com)]
- 11. [bio-rad-antibodies.com](https://www.bio-rad-antibodies.com) [[bio-rad-antibodies.com](https://www.bio-rad-antibodies.com)]
- 12. [bosterbio.com](https://www.bosterbio.com) [[bosterbio.com](https://www.bosterbio.com)]
- 13. Flow (Intracellular) Protocol for CCR2 Antibody (NBP1-48337): Novus Biologicals [[novusbio.com](https://www.novusbio.com)]
- 14. [repository.up.ac.za](https://www.repository.up.ac.za) [[repository.up.ac.za](https://www.repository.up.ac.za)]
- 15. [researchgate.net](https://www.researchgate.net) [[researchgate.net](https://www.researchgate.net)]
- 16. Sequential staining improves detection of CCR2 and CX3CR1 on monocytes when simultaneously evaluating CCR5 by multicolor flow cytometry - PubMed [[pubmed.ncbi.nlm.nih.gov](https://pubmed.ncbi.nlm.nih.gov)]
- 17. [researchgate.net](https://www.researchgate.net) [[researchgate.net](https://www.researchgate.net)]
- To cite this document: BenchChem. [Application Notes and Protocols for Identifying CCR2-Expressing Cells via Flow Cytometry]. BenchChem, [2026]. [Online PDF]. Available at: [<https://www.benchchem.com/product/b3037638/docs#application-notes-and-protocols-for-identifying-ccr2-expressing-cells-via-flow-cytometry>]

---

### Disclaimer & Data Validity:

The information provided in this document is for Research Use Only (RUO) and is strictly not intended for diagnostic or therapeutic procedures. While BenchChem strives to provide accurate protocols, we make no warranties, express or implied, regarding the fitness of this product for every specific experimental setup.

**Technical Support:** The protocols provided are for reference purposes. Unsure if this reagent suits your experiment?

**Need Industrial/Bulk Grade?** [Request Custom Synthesis Quote](#)

## BenchChem

Our mission is to be the trusted global source of essential and advanced chemicals, empowering scientists and researchers to drive progress in science and industry.

### Contact

Address: 3281 E Guasti Rd  
Ontario, CA 91761, United States  
Phone: (601) 213-4426  
Email: [info@benchchem.com](mailto:info@benchchem.com)

[Contact our Ph.D. Support Team for a compatibility check](#)