

# Small Molecule p38 MAPK Inhibitors: The Pyrazole Class

**Author:** BenchChem Technical Support Team. **Date:** April 2026

## Compound of Interest

**Compound Name:** *1,4-bis(3-chlorophenyl)-1H-pyrazol-5-amine*

**CAS No.:** 324008-94-8

**Cat. No.:** B3035516

[Get Quote](#)

## Design, Mechanism, and Experimental Validation[1][2]

### Executive Summary

The p38 mitogen-activated protein kinase (MAPK) pathway is a central regulator of proinflammatory cytokine production (TNF-

, IL-1

, IL-6), making it a high-value target for autoimmune diseases such as rheumatoid arthritis and Crohn's disease. Among the diverse chemotypes developed, the pyrazole class stands out for its structural versatility, allowing access to both ATP-competitive (Type I) and allosteric (Type II) inhibition modes.

This technical guide provides a rigorous analysis of pyrazole-based p38 inhibitors. It dissects the structure-activity relationships (SAR) governing their potency, details the "DFG-out" binding kinetics characteristic of high-affinity ligands like Doramapimod (BIRB-796), and provides self-validating protocols for biochemical and cellular assessment.

## Mechanistic Architecture

### The p38 Signaling Cascade

p38 MAPK (specifically the p38

isoform) acts as a signal integration hub.<sup>[1]</sup> Stress stimuli (UV, osmotic shock) or cytokines activate upstream MAP3Ks (e.g., ASK1, TAK1), which phosphorylate MKK3/6. These kinases dual-phosphorylate p38 on the Thr-Gly-Tyr (TGY) motif, activating it to phosphorylate downstream effectors like MK2 and transcription factors (ATF2), driving cytokine translation.

### Visualization: p38 MAPK Signaling Pathway

The following diagram illustrates the canonical activation cascade and the specific intervention point of pyrazole inhibitors.

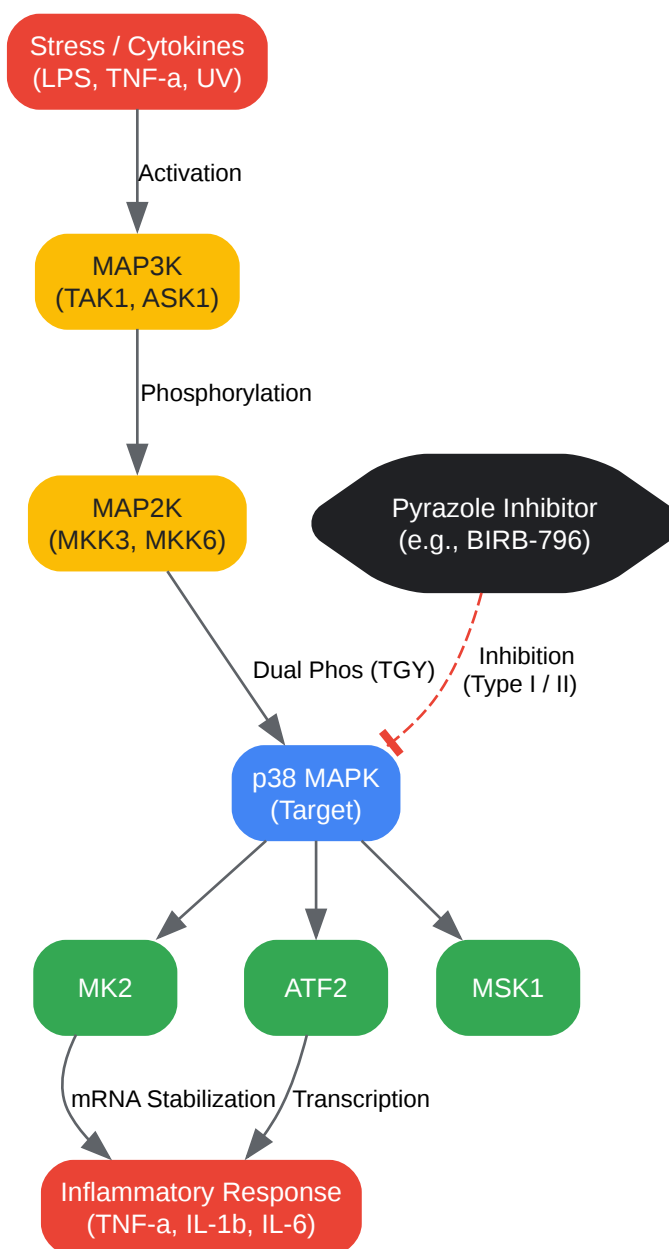

[Click to download full resolution via product page](#)

Figure 1: Canonical p38 MAPK signaling cascade showing the intervention point of small molecule inhibitors.

## Medicinal Chemistry & SAR: The Pyrazole Scaffold

The pyrazole ring serves as a critical scaffold due to its ability to function as both a hydrogen bond donor and acceptor, facilitating interactions with the kinase hinge region or the allosteric "selectivity pocket."

## Binding Modes: Type I vs. Type II

- Type I (ATP-Competitive): Binds to the active conformation (DFG-in). The pyrazole often mimics the adenine ring of ATP, forming H-bonds with the hinge region (Met109).
- Type II (Allosteric/DFG-out): Compounds like BIRB-796 stabilize the inactive "DFG-out" conformation. This mode offers higher selectivity (slow dissociation rates) but requires a specific structural pharmacophore (often a urea linker) attached to the pyrazole.

## Core SAR Analysis (Pyrazole-Urea Class)

Using BIRB-796 (Doramapimod) as the archetype, the SAR is defined by three distinct regions:

Region	Structural Motif	Function & Interaction
Hinge Binder	Morpholine/Ethoxy moiety	Extends into the ATP pocket; improves solubility and affinity.
Linker	Pyrazole-Urea	The urea NHs form a bidentate H-bond with Glu71 (a key catalytic residue). The pyrazole ring acts as a rigid spacer.
Hydrophobic Tail	N-1 Aryl / Naphthalene	Occupies the allosteric "selectivity pocket" created by the DFG-out shift (Phe169 moves).

## Optimization: The Pyridyl-to-Pyrimidine Switch

In the development of SD-0006, researchers observed that replacing the C-4 pyridyl ring with a pyrimidine significantly enhanced potency.

- C-4 Position: Aromatic heterocycles here interact with the "gatekeeper" residue (Thr106).
- C-5 Position: Lipophilic groups (e.g., tert-butyl or phenyl) at C-5 stabilize the pyrazole orientation via hydrophobic packing.

## Visualization: Pyrazole SAR Logic

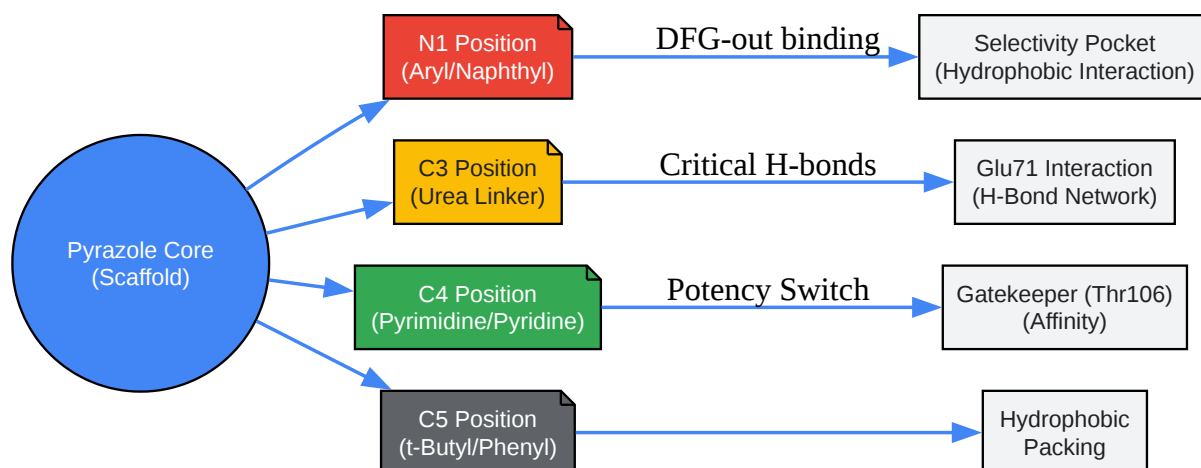

[Click to download full resolution via product page](#)

Figure 2: Structure-Activity Relationship (SAR) map for Pyrazole-Urea p38 inhibitors.

## Experimental Protocols

To validate a pyrazole inhibitor, one must assess both biochemical potency (binding/inhibition) and cellular efficacy (pathway suppression).

### Protocol A: TR-FRET Binding Assay (Biochemical)

Objective: Determine the

or

of the inhibitor by displacing a tracer from the p38 active site. Method: Time-Resolved Fluorescence Resonance Energy Transfer (TR-FRET).

Reagents:

- Recombinant human p38  
(biotinylated).
- Europium-labeled anti-GST or anti-His antibody (Donor).

- AlexaFluor 647-labeled ATP-competitive tracer (Acceptor).
- Assay Buffer: 50 mM HEPES pH 7.5, 10 mM  
, 1 mM EGTA, 0.01% Brij-35.

#### Step-by-Step Workflow:

- Preparation: Dilute inhibitor in DMSO (10-point dose response). Transfer 50 nL to a low-volume 384-well black plate.
- Enzyme Mix: Prepare p38  
(5 nM final) + Eu-Antibody (2 nM final) in Assay Buffer. Add 5  
L to wells.
- Pre-incubation: Incubate for 15 minutes at RT (allows slow-binding Type II inhibitors to equilibrate).
- Tracer Addition: Add 5  
L of Tracer (concentration =  
of tracer, typically 10-20 nM).
- Equilibration: Incubate for 60 minutes at RT in the dark.
- Detection: Read on a TR-FRET compatible reader (Excitation: 337 nm; Emission: 665 nm / 615 nm).
- Analysis: Calculate Ratio (665/615). Plot % Inhibition vs. Log[Concentration] to derive  
.

## Protocol B: Cellular TNF- Release Assay

Objective: Measure functional inhibition of the p38 pathway in a physiological context. Cell Line: THP-1 (Human monocytic leukemia) or PBMCs.

### Step-by-Step Workflow:

- Differentiation (THP-1 only): Treat THP-1 cells with PMA (100 ng/mL) for 48h to induce macrophage-like phenotype.
- Seeding: Plate cells at  
  
cells/well in 96-well plates in RPMI-1640 + 10% FBS.
- Inhibitor Treatment: Add serial dilutions of the pyrazole inhibitor. Incubate for 1 hour prior to stimulation.
- Stimulation: Add Lipopolysaccharide (LPS) (final conc. 1  
  
g/mL).
- Incubation: Incubate for 4 hours at 37°C, 5%  
  
.
- Harvest: Centrifuge plate (1000 rpm, 5 min) and collect supernatant.
- Quantification: Measure TNF-  
  
levels using a standard ELISA kit.
- Validation: Cytotoxicity control (MTS/MTT assay) is required to ensure reduced TNF-  
  
is not due to cell death.

## Visualization: Experimental Workflow

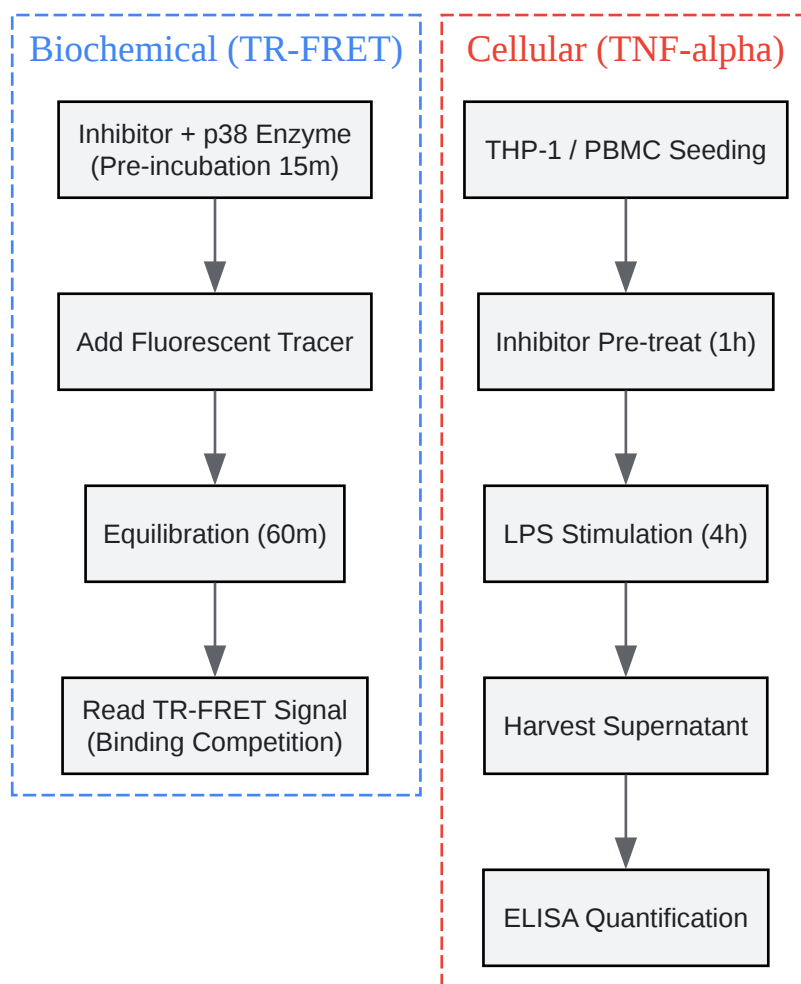

[Click to download full resolution via product page](#)

Figure 3: Parallel workflows for biochemical validation and cellular efficacy profiling.

## Key Compounds & Data Summary

The following table summarizes key pyrazole-based inhibitors referenced in literature, highlighting their binding kinetics and clinical status.

Compound	Structure Class	Binding Mode	Key Feature	Status
BIRB-796 (Doramapimod)	N-pyrazole-N'- aryl urea	Type II (DFG- out)	High affinity, slow dissociation. Bidentate H- bond with Glu71.	Ph II/III (Discontinued)
SC-806	N-pyrazole	Type I	Pyrazole N2 interacts with Asp168.	Preclinical Tool
SD-0006	Diaryl pyrazole	Type I / Hybrid	Pyrimidine at C4 improves potency over pyridine.[2]	Ph I (Discontinued)
PH-797804	Pyridinone- pyrazole	Type I	High selectivity; forms H-bonds with Met109 and Gly110.	Ph II

## References

- Regan, J., et al. (2002). "Pyrazole Urea-Based Inhibitors of p38 MAP Kinase: From Lead Compound to Clinical Candidate." *Journal of Medicinal Chemistry*.
- Pargellis, C., et al. (2002). "Inhibition of p38 MAP kinase by utilizing a novel allosteric binding site." *Nature Structural Biology*.
- Walker, J. K., et al. (2010).[2] "Identification of SD-0006, a potent diaryl pyrazole inhibitor of p38 MAP kinase." [2] *Bioorganic & Medicinal Chemistry Letters*.
- Dumas, J. (2001). "MAP kinase inhibitors: p38, MEK and RAF." *Current Opinion in Drug Discovery & Development*.
- ThermoFisher Scientific. "LanthaScreen™ Eu Kinase Binding Assay for p38 alpha." *User Guide*.

### Need Custom Synthesis?

BenchChem offers custom synthesis for rare earth carbides and specific isotopic labeling.

Email: [info@benchchem.com](mailto:info@benchchem.com) or [Request Quote Online](#).

## Sources

- [1. chemrevlett.com \[chemrevlett.com\]](http://chemrevlett.com)
- [2. Identification of SD-0006, a potent diaryl pyrazole inhibitor of p38 MAP kinase - PubMed \[pubmed.ncbi.nlm.nih.gov\]](#)
- To cite this document: BenchChem. [Small Molecule p38 MAPK Inhibitors: The Pyrazole Class]. BenchChem, [2026]. [Online PDF]. Available at: [\[https://www.benchchem.com/product/b3035516/docs#small-molecule-p38-mapk-inhibitors-the-pyrazole-class\]](https://www.benchchem.com/product/b3035516/docs#small-molecule-p38-mapk-inhibitors-the-pyrazole-class)

### Disclaimer & Data Validity:

The information provided in this document is for Research Use Only (RUO) and is strictly not intended for diagnostic or therapeutic procedures. While BenchChem strives to provide accurate protocols, we make no warranties, express or implied, regarding the fitness of this product for every specific experimental setup.

**Technical Support:** The protocols provided are for reference purposes. Unsure if this reagent suits your experiment?

**Need Industrial/Bulk Grade?** [Request Custom Synthesis Quote](#)

## BenchChem

Our mission is to be the trusted global source of essential and advanced chemicals, empowering scientists and researchers to drive progress in science and industry.

### Contact

Address: 3281 E Guasti Rd

Ontario, CA 91761, United States

Phone: (601) 213-4426

Email: [info@benchchem.com](mailto:info@benchchem.com)

Contact our Ph.D. Support Team for a compatibility check