

Functionalization of 5-(4-Chlorophenyl)-2-(methylsulfanyl)pyrimidine at C-4 position

Author: BenchChem Technical Support Team. **Date:** May 2026

Compound of Interest

Compound Name: 5-(4-Chlorophenyl)-2-(methylsulfanyl)pyrimidine

CAS No.: 31408-25-0

Cat. No.: B3035303

[Get Quote](#)

Application Note: Advanced Functionalization Strategies for **5-(4-Chlorophenyl)-2-(methylsulfanyl)pyrimidine** at the C-4 Position

Executive Summary & Scope

This technical guide addresses the regioselective functionalization of **5-(4-Chlorophenyl)-2-(methylsulfanyl)pyrimidine** (CAS: 31408-24-9) at the C-4 position. This scaffold is a privileged intermediate in the synthesis of p38 MAP kinase inhibitors, antifungals, and adenosine receptor antagonists.

The C-4 position of the pyrimidine ring is electronically activated (electron-deficient) yet sterically accessible. Functionalization at this site typically involves replacing the C-4 hydrogen () with carbon () or

) or heteroatom substituents. This guide details three validated workflows:

- Iridium-Catalyzed C-H Borylation: For installing a versatile boronate handle.
- Directed Ortho-Lithiation (DoL): For introduction of electrophiles (formyl, iodo, etc.).
- Radical C-H Alkylation (Minisci): For direct alkylation, with caveats regarding the sulfide moiety.

Structural Analysis & Reactivity Profile

- Substrate: **5-(4-Chlorophenyl)-2-(methylsulfanyl)pyrimidine**.
- Symmetry: The molecule possesses a local plane of symmetry (assuming rapid rotation of the C-5 aryl group). The C-4 and C-6 positions are chemically equivalent.
- Chemo-selectivity Challenges:
 - Sulfide (SMe): Susceptible to oxidation (to sulfoxide/sulfone) under strong oxidative conditions (e.g., standard Minisci).
 - Aryl Chloride (Cl): Susceptible to metal-catalyzed oxidative addition (e.g., Pd(0)), requiring orthogonal catalyst selection.
 - C-4 vs. C-6: Mono-functionalization is the primary goal; controlling stoichiometry is critical to prevent C-4,6-disubstitution.

Protocol A: Iridium-Catalyzed C-H Borylation (The "Gold Standard")

This method is preferred for its mild conditions, high functional group tolerance (compatible with Ar-Cl and S-Me), and exclusive regioselectivity for sterically accessible C-H bonds.

Mechanism: The active catalyst, an Ir(III)-tris-boryl species, activates the C-H bond via an oxidative addition/reductive elimination cycle, governed by steric factors. The C-4 position is sterically exposed compared to the C-5 aryl interface.

Materials:

- Catalyst Precursor:

(1.5 mol%)
- Ligand: 4,4'-Di-tert-butyl-2,2'-bipyridine (dtbpy) (3 mol%)
- Boron Source:

(Bis(pinacolato)diboron) (1.1 equiv)
- Solvent: MTBE or THF (anhydrous)
- Temperature: 60–80 °C

Step-by-Step Protocol:

- Catalyst Formation: In a glovebox or under Argon, charge a reaction vial with

(10 mg, 0.015 mmol) and dtbpy (8 mg, 0.03 mmol). Dissolve in 2 mL MTBE. The solution should turn dark brown/red.
- Reagent Addition: Add

(280 mg, 1.1 mmol) and the pyrimidine substrate (1.0 mmol).
- Reaction: Seal the vial and heat to 60 °C for 4–16 hours. Monitor by LC-MS.
- Workup: Cool to RT. The pinacol boronate ester is often stable. Concentrate in vacuo.
- Purification: Pass through a short plug of silica gel (eluting with EtOAc/Hexane) to remove the catalyst. Note: Pinacol boronates can degrade on silica; rapid filtration is recommended.

Outcome: 5-(4-Chlorophenyl)-2-(methylsulfanyl)-4-(4,4,5,5-tetramethyl-1,3,2-dioxaborolan-2-yl)pyrimidine. This intermediate is ready for Suzuki-Miyaura coupling.

Protocol B: Directed Ortho-Lithiation (DoL)

This method utilizes the inherent acidity of the C-4 proton (adjacent to nitrogen) to generate a lithiated species that can be trapped with various electrophiles.

Critical Constraint: Standard n-BuLi must NOT be used, as it acts as a nucleophile and will attack the C-4 position (Chichibabin-like addition). You must use LiTMP (Lithium 2,2,6,6-tetramethylpiperidide), a non-nucleophilic, bulky base.

Materials:

- Base: LiTMP (generated in situ from TMP and n-BuLi)
- Solvent: THF (anhydrous), -78 °C
- Electrophile: DMF (for -CHO),
(for -I), or
(for -COOH)

Step-by-Step Protocol:

- LiTMP Preparation: To a flame-dried flask under
, add THF (10 mL) and 2,2,6,6-tetramethylpiperidine (1.2 equiv). Cool to -78 °C. Add n-BuLi (1.2 equiv) dropwise. Stir for 30 min at 0 °C, then cool back to -78 °C.
- Lithiation: Dissolve the pyrimidine substrate (1.0 mmol) in THF (2 mL) and add dropwise to the LiTMP solution at -78 °C.
 - Observation: The solution often turns deep red/orange (formation of pyrimidyl anion).
 - Time: Stir for 30–45 minutes. (Do not prolong, as the SMe group can direct lithiation or undergo elimination).
- Trapping: Add the electrophile (e.g., DMF, 2.0 equiv) rapidly.
- Quench: Allow to warm to RT, then quench with sat.

- Isolation: Extract with EtOAc, dry over

, and concentrate.

Protocol C: Radical C-H Alkylation (Minisci-Type)

Useful for adding alkyl groups (e.g., hydroxymethyl, isopropyl). Warning: Classical Minisci conditions use Persulfate (

), which will oxidize the 2-SMe group to a sulfoxide or sulfone. If the sulfide is needed, use Photoredox conditions (Zinc sulfinates). If the sulfone is the desired product (as a leaving group), classical conditions are acceptable.

Variant: Classical Minisci (Oxidative)

- Reagents: Alkyl carboxylic acid (R-COOH),

(cat.),

.

- Solvent:

(biphasic) + TFA (1 equiv to protonate the pyrimidine).

Step-by-Step Protocol:

- Dissolve substrate (1 mmol) in
(1:1). Add TFA (1.0 equiv).
- Add the carboxylic acid (e.g., isobutyric acid, 5 equiv).
- Add
(0.2 equiv).
- Heat to 50 °C and add
(3 equiv) dropwise over 30 mins.

- Result: Expect oxidation of SMe to alongside C-4 alkylation.

Data Summary & Comparison

Feature	Ir-Catalyzed Borylation	Lithiation (LiTMP)	Minisci (Classical)
Primary Product	C-4 Boronate	C-4 Electrophile (I, CHO)	C-4 Alkyl
SMe Compatibility	High	High (at -78°C)	Low (Oxidizes to)
Ar-Cl Tolerance	High	Moderate (Benzynes risk if >0°C)	High
Scalability	Good (Expensive catalyst)	Moderate (Cryogenic)	Excellent
Regioselectivity	Steric (>95% C-4)	Acid/Base (>90% C-4)	Electronic (C-4/C-6 mix)

Pathway Visualization

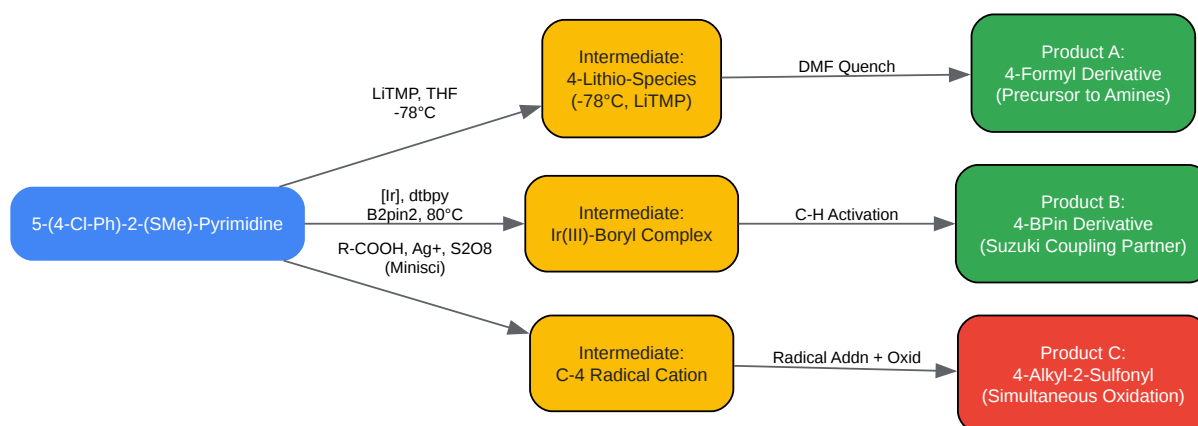

[Click to download full resolution via product page](#)

Caption: Divergent functionalization pathways for **5-(4-Chlorophenyl)-2-(methylsulfanyl)pyrimidine**, highlighting intermediate species and final functional handles.

References

- Minisci Reaction on Pyrimidines: Duncton, M. A. J. (2011). Minisci reactions: Versatile tools for the functionalization of heterocycles. *Med.[1][2][3] Chem. Commun.*, 2, 1135-1161. [Link](#)
- Ir-Catalyzed Borylation: Mkhaliid, I. A. I., Barnard, J. H., Marder, T. B., Murphy, J. M., & Hartwig, J. F. (2010). C-H Activation for the Construction of C-B Bonds. *Chem. Rev.*, 110(2), 890–931. [Link](#)
- Lithiation of Pyrimidines: Plé, N., Turck, A., Mojovic, L., & Quéguiner, G. (1994). Metalation of diazines. XI. Directed ortho-lithiation of fluoropyrimidines. *J. Organomet. Chem.*, 41(12), 5-18. [Link](#)
- C-4 Arylation Guidelines: Gulevich, A. V., Dudnik, A. S., Chernyak, N., & Gevorgyan, V. (2013). Transition Metal-Mediated C–H Functionalization of Heteroarenes. *Chem. Rev.*, 113(5), 3084–3213. [Link](#)
- Specific Scaffold Context: Aswinanand, B., et al. (2025). Pyrimidine Derivative...[2][3][4][5][6][7] Ameliorates Cognitive Dysfunction.[4] *J. Neuroimmune Pharmacol.* 20(1):94. [Link](#)

Need Custom Synthesis?

BenchChem offers custom synthesis for rare earth carbides and specific isotopic labeling.

Email: info@benchchem.com or [Request Quote Online](#).

Sources

- [1. Directed Lithiation of Protected 4-Chloropyrrolopyrimidine: Addition to Aldehydes and Ketones Aided by Bis\(2-dimethylaminoethyl\)ether - PMC \[pmc.ncbi.nlm.nih.gov\]](#)
- [2. pubs.acs.org \[pubs.acs.org\]](#)
- [3. pdfs.semanticscholar.org \[pdfs.semanticscholar.org\]](#)

- [4. Pyrimidine Derivative, \(E\)-N-\[4-\(4-Chlorophenyl\)-6-\(4-Methylphenyl\)Pyrimidin-2-yl\]-1-\(Furan-2-yl\)Methanimine, Named BN5 Ameliorates Cognitive Dysfunction and Regulates esr1 and esr2b Expression in Female In Vivo Zebrafish Alzheimer Model - PubMed \[pubmed.ncbi.nlm.nih.gov\]](#)
- [5. Pyrimidine as an Aryl C-H Activating Group - PubMed \[pubmed.ncbi.nlm.nih.gov\]](#)
- [6. researchgate.net \[researchgate.net\]](#)
- [7. Comprehensive perspectives of metal and metal-free C–H activation approaches in pyrimidines and related heteroarenes: scope, mechanistic insights, and ... - RSC Advances \(RSC Publishing\) DOI:10.1039/D5RA07044A \[pubs.rsc.org\]](#)
- To cite this document: BenchChem. [Functionalization of 5-(4-Chlorophenyl)-2-(methylsulfanyl)pyrimidine at C-4 position]. BenchChem, [2026]. [Online PDF]. Available at: [\[https://www.benchchem.com/product/b3035303/docs#functionalization-of-5-4-chlorophenyl-2-methylsulfanyl-pyrimidine-at-c-4-position\]](https://www.benchchem.com/product/b3035303/docs#functionalization-of-5-4-chlorophenyl-2-methylsulfanyl-pyrimidine-at-c-4-position)

Disclaimer & Data Validity:

The information provided in this document is for Research Use Only (RUO) and is strictly not intended for diagnostic or therapeutic procedures. While BenchChem strives to provide accurate protocols, we make no warranties, express or implied, regarding the fitness of this product for every specific experimental setup.

Technical Support: The protocols provided are for reference purposes. Unsure if this reagent suits your experiment?

Need Industrial/Bulk Grade? [Request Custom Synthesis Quote](#)

BenchChem

Our mission is to be the trusted global source of essential and advanced chemicals, empowering scientists and researchers to drive progress in science and industry.

Contact

Address: 3281 E Guasti Rd
Ontario, CA 91761, United States
Phone: (601) 213-4426
Email: info@benchchem.com

Contact our Ph.D. Support Team for a compatibility check