

Technical Support Center: Troubleshooting Quinoline Synthesis

Author: BenchChem Technical Support Team. **Date:** April 2026

Compound of Interest

Compound Name: *4-Chloro-6-iodoquinoline-3-carbonitrile*

CAS No.: *214483-20-2*

Cat. No.: *B3034737*

[Get Quote](#)

Status: Active Operator: Senior Application Scientist Ticket ID: QUIN-SYNTH-2024 Audience: Research Chemists, Process Development Scientists

Introduction

Welcome to the Quinoline Synthesis Technical Support Center. You are likely here because your reaction turned into a black tar, exploded out of the condenser, or yielded an inseparable mixture of regioisomers. This guide bypasses textbook generalities to address the specific failure modes of quinoline heterocycle construction. We treat every protocol as a system that requires precise tuning of kinetics, thermodynamics, and steric control.

Module 1: The "Violent" Classics (Skraup & Doebner-von Miller)

Core Issue: Exothermic runaway and polymerization of

-unsaturated intermediates.[1]

Troubleshooting Guide

Q: My Skraup reaction proceeds violently, often ejecting material through the condenser. How do I control the exotherm without killing the yield? A: The violence stems from the simultaneous dehydration of glycerol to acrolein and the subsequent conjugate addition/oxidation steps.

- The Fix: Add a moderator. Ferrous sulfate () is the industry standard. It acts as an oxygen carrier and redox buffer, smoothing out the oxidation profile.
- Alternative: Use Boric Acid (). It forms a borate ester with glycerol, slowing its dehydration to acrolein and preventing a sudden spike in concentration of this reactive intermediate.

Q: I am getting <20% yield and a flask full of insoluble black tar (polymer). A: This is "acrolein polymerization." In the presence of hot concentrated sulfuric acid, acrolein polymerizes faster than it reacts with aniline.

- The Fix:
 - Dilution: Do not run neat. Use acetic acid (AcOH) as a co-solvent to mitigate local hot spots.
 - Oxidant Switch: Replace nitrobenzene (which requires high T) with Iodine () or Sodium 3-nitrobenzenesulfonate (water-soluble, easier workup).
 - Protocol Adjustment: See the Moderated Skraup Protocol below.

Standard Operating Procedure: Moderated Skraup Synthesis

Target: 6-Methylquinoline

- Setup: 500 mL 3-neck RBF, reflux condenser, mechanical stirrer (magnetic stirring will fail once tar forms).

- Reagents:
 - p-Toluidine (0.2 mol)
 - Glycerol (0.6 mol)
 - Ferrous Sulfate heptahydrate (2 g) - The Moderator
 - Nitrobenzene (0.12 mol) - The Oxidant
 - Conc.
(100 g)
- Execution:
 - Mix amine, glycerol, FeSO₄, and nitrobenzene.
 - Add

dropwise with cooling if T > 50°C.
 - Critical Step: Heat slowly to reflux. If the mixture bubbles aggressively, remove heat immediately. The FeSO₄ should keep the boil steady.
 - Reflux for 4 hours.[2]
- Workup: Steam distill to remove unreacted nitrobenzene. Basify residue with NaOH.[1][3]
Steam distill again to collect product.

Decision Tree: Skraup/Doebner-von Miller Troubleshooting

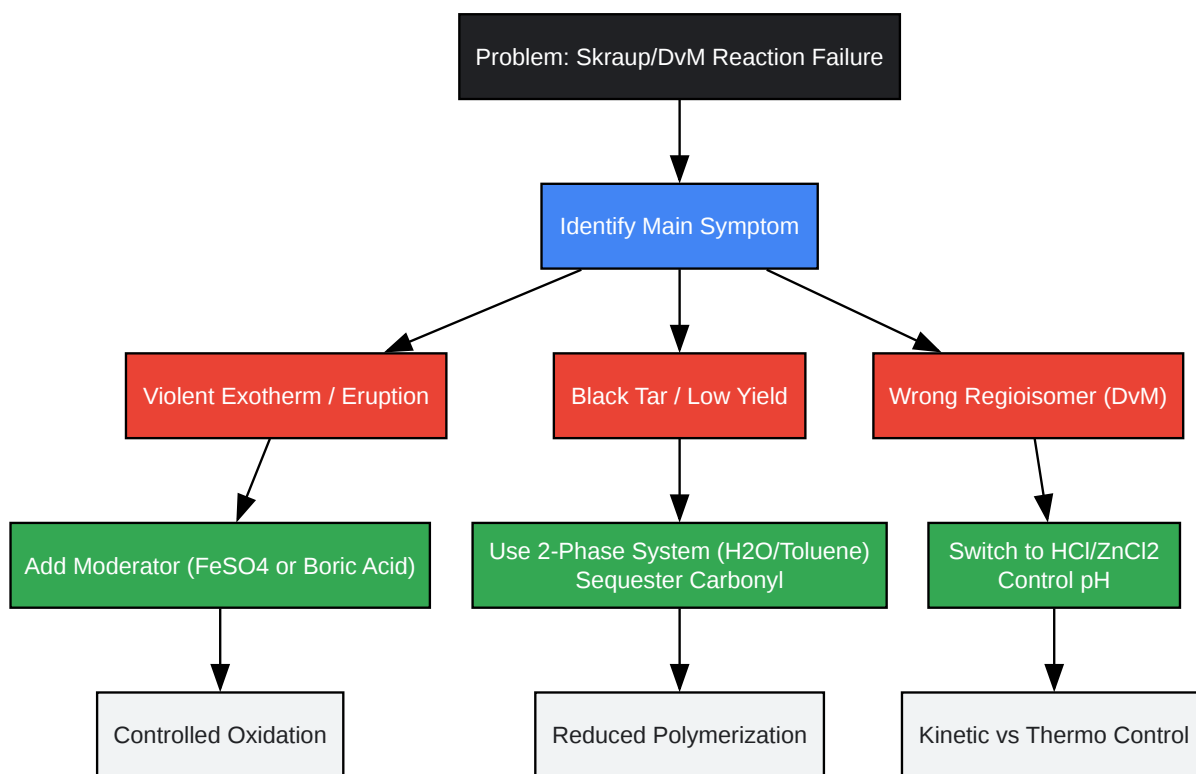

[Click to download full resolution via product page](#)

Caption: Diagnostic flow for stabilizing Skraup and Doebner-von Miller (DvM) reactions.

Module 2: Condensation & Regioselectivity (Friedländer & Combes)

Core Issue: Competition between cyclization and self-condensation (Aldol).

Troubleshooting Guide

Q: In my Friedländer synthesis, the 2-aminoaryl ketone is not condensing with the ketone/aldehyde. I see starting material and self-condensation products. A: The "active methylene" component often undergoes self-aldol condensation faster than it reacts with the aminoketone.

- The Fix:

- Catalyst Switch: Move away from strong bases (KOH). Use Brønsted acids (p-TsOH) or Lewis acids (,) which activate the carbonyl without promoting rapid enolate polymerization.
- Solvent-Free: Run the reaction neat (solvent-free) at 80°C. High concentration favors the bimolecular cross-condensation over unimolecular degradation.

Q: My Combes synthesis gave the wrong regioisomer (4-substituted instead of 2-substituted).

A: Combes regioselectivity is dictated by the interplay of steric bulk and the electronic nature of the aniline.

- Mechanism: The reaction proceeds via a Schiff base (anil) intermediate.
 - Kinetic Product: Attack at the less hindered carbonyl.
 - Thermodynamic Product: Cyclization onto the more electron-rich position.^[4]
- The Fix: See the Regioselectivity Matrix below.

Data Table: Controlling Regioselectivity in Combes Synthesis

Desired Product	Key Substituent Effect	Recommended Condition	Mechanism Driver
2-Substituted	Bulky R-group on Diketone	Use meta-substituted anilines with electron-donating groups (EDG).	Steric hindrance directs initial attack to less hindered carbonyl.
4-Substituted	Small R-group / EDG on Aniline	Use strong acid catalysis (Polyphosphoric Acid - PPA).	Acid promotes rapid equilibration to the thermodynamic enamine.
Mixture	Neutral Aniline	Solvent polarity tuning.	Switch from EtOH to Toluene to alter transition state solvation.

Module 3: Modern Methods (Povarov & Metal-Catalyzed)

Core Issue: Diastereocontrol and Catalyst Deactivation.

Troubleshooting Guide

Q: My Povarov (Aza-Diels-Alder) reaction yields a mix of cis and trans tetrahydroquinolines. How do I favor the cis-isomer? A: The Povarov reaction can proceed via a concerted [4+2] (favoring endo/cis) or a stepwise Mannich/Michael pathway (favoring thermodynamic trans).

- The Fix:

- Lewis Acid: Use

or

. These lanthanide triflates coordinate tightly to the imine, enforcing a concerted endo transition state.

- Temperature: Lower the temperature to 0°C or RT. High heat (>80°C) promotes the stepwise mechanism and trans isomer.

Q: My Pd-catalyzed C-H activation to form quinolines stops at 50% conversion (Catalyst Poisoning). A: Nitrogen heterocycles are notorious for coordinating to Pd, shutting down the catalytic cycle.

- The Fix:

- Oxidant: If using

as a terminal oxidant, ensure it is anhydrous. Water can hydrolyze the catalyst.

- Additives: Add Pivalic Acid (30 mol%). It acts as a proton shuttle, facilitating the C-H activation step and preventing the Pd from getting "stuck" on the nitrogen.

Mechanism Diagram: Povarov Selectivity

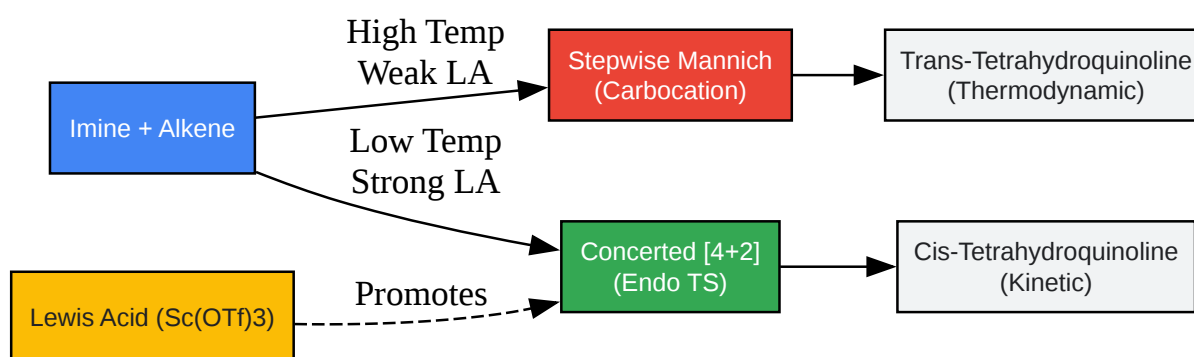

[Click to download full resolution via product page](#)

Caption: Pathway selection in Povarov synthesis. Strong Lewis acids and low temperatures favor the concerted (cis) pathway.

Module 4: Purification of "Tarry" Crudes

Core Issue: Isolating product from polymeric sludge.

The "Zinc Dust" Trick: If your quinoline is trapped in a viscous black oil that clogs columns:

- Dissolve the crude tar in dilute HCl. Filter off insoluble polymer.
- Basify filtrate with NaOH to release the free base.
- Distillation: Add a spatula tip of Zinc Dust to the distillation flask.
 - Why? Zinc prevents oxidative polymerization during heating and reduces trace N-oxides back to the quinoline.
- Collect the fraction. If it is still colored, dissolve in ether and precipitate as the Picrate salt (add saturated picric acid in ethanol). Recrystallize the picrate, then free the base with NaOH.

References

- Skraup Synthesis Moderators:Organic Syntheses, Coll. Vol. 1, p. 478 (1941). [Link](#)
- Doebner-von Miller Regioselectivity:Chemical Reviews, 1944, 35 (2), pp 151–217. [Link](#)
- Friedländer Synthesis Improvements:Journal of Organic Chemistry, 2011, 76, 1, 222–227. [Link](#)
- Povarov Reaction Mechanism:Chemical Reviews, 2010, 110, 10, 6104–6143. [Link](#)
- Metal-Catalyzed C-H Activation:Journal of the American Chemical Society, 2008, 130, 26, 8136–8137. [Link](#)

Need Custom Synthesis?

BenchChem offers custom synthesis for rare earth carbides and specific isotopic labeling.

Email: info@benchchem.com or [Request Quote Online](#).

Sources

- [1. pdf.benchchem.com](https://pdf.benchchem.com) [pdf.benchchem.com]
- [2. pdf.benchchem.com](https://pdf.benchchem.com) [pdf.benchchem.com]

- [3. Synthesis, Reactions and Medicinal Uses of Quinoline | Pharmaguideline \[pharmaguideline.com\]](#)
- [4. Povarov reaction - Wikipedia \[en.wikipedia.org\]](#)
- To cite this document: BenchChem. [Technical Support Center: Troubleshooting Quinoline Synthesis]. BenchChem, [2026]. [Online PDF]. Available at: [\[https://www.benchchem.com/product/b3034737/docs#technical-support-center-troubleshooting-quinoline-synthesis\]](https://www.benchchem.com/product/b3034737/docs#technical-support-center-troubleshooting-quinoline-synthesis)

Disclaimer & Data Validity:

The information provided in this document is for Research Use Only (RUO) and is strictly not intended for diagnostic or therapeutic procedures. While BenchChem strives to provide accurate protocols, we make no warranties, express or implied, regarding the fitness of this product for every specific experimental setup.

Technical Support: The protocols provided are for reference purposes. Unsure if this reagent suits your experiment?

Need Industrial/Bulk Grade? [Request Custom Synthesis Quote](#)

BenchChem

Our mission is to be the trusted global source of essential and advanced chemicals, empowering scientists and researchers to drive progress in science and industry.

Contact

Address: 3281 E Guasti Rd
Ontario, CA 91761, United States
Phone: (601) 213-4426
Email: info@benchchem.com

[Contact our Ph.D. Support Team for a compatibility check](#)

