

Comparative Reactivity Guide: m-Bromo- vs. p-Bromo- -Methylstyrene

Author: BenchChem Technical Support Team. **Date:** April 2026

Compound of Interest

Compound Name: 1-Bromo-3-(1-propen-2-yl)benzene
CAS No.: 25108-58-1
Cat. No.: B3034903

[Get Quote](#)

Executive Summary

This guide provides a technical comparison of 3-bromo-

-methylstyrene (m-BAMS) and 4-bromo-

-methylstyrene (p-BAMS). Designed for researchers in polymer chemistry and organic synthesis, this analysis focuses on the distinct electronic and steric factors driving their reactivity in anionic polymerization, lithium-halogen exchange, and palladium-catalyzed cross-coupling.

Key Distinction: The reactivity divergence is primarily driven by the Hammett substituent effects and the steric inhibition of resonance inherent to the

-methylstyrene scaffold.[1][2]

- m-BAMS: Dominated by strong inductive electron withdrawal (), leading to faster nucleophilic attack (initiation) and facile oxidative addition.[3]

- p-BAMS: Characterized by competing inductive withdrawal and resonance donation (), resulting in greater radical stability and distinct anionic propagation kinetics.[1][2][3]

Electronic & Structural Profile

The

-methyl group in these styrenic monomers introduces significant steric strain, forcing the phenyl ring to twist out of coplanarity with the vinyl group (dihedral angle

).[3] This structural distortion attenuates resonance effects, making inductive effects the primary driver of reactivity differences.[1]

Table 1: Physicochemical & Electronic Comparison

Property	m-Bromo- -methylstyrene	p-Bromo- -methylstyrene	Mechanistic Implication
Hammett Constant ()	0.39 (Strong EWG)	0.23 (Moderate EWG)	Meta is more electron-deficient; faster nucleophilic attack.
Resonance Effect	Negligible (Node position)	Present (+R), but attenuated by twist	Para retains some radical stabilization capability.[1][3]
LUMO Energy	Lower	Higher	Meta is a harder electrophile.[1][2][3]
Steric Environment	Unhindered vinyl group	Unhindered vinyl group	Similar steric access to the double bond; ortho positions differ. [1][2]

Anionic Polymerization Reactivity[3][4]

In anionic polymerization, the substituent on the phenyl ring dictates both the initiation rate (attack on the monomer) and the propagation rate (stability of the living carbanion).[1][3]

Initiation Kinetics

The initiation step involves the nucleophilic attack of an initiator (e.g., sec-BuLi) onto the β -carbon of the vinyl group.^[1]

- m-BAMS (Faster Initiation): The stronger electron-withdrawing nature of the meta-bromo group () significantly reduces electron density at the vinyl double bond compared to the para isomer.^[1] This makes m-BAMS more susceptible to nucleophilic attack.^[1]
- p-BAMS (Slower Initiation): The electron-withdrawing inductive effect is partially offset by resonance donation (lone pair donation from Br), resulting in a higher electron density at the vinyl group compared to the meta isomer.^{[1][3]}

Propagation & Living Chain Stability

Once initiated, the stability of the propagating carbanion determines the reaction control.^[1]

- m-BAMS Carbanion: The negative charge is stabilized purely by induction.^{[1][2]} This creates a "tighter" ion pair with the counter-cation (e.g., Li), potentially slowing down the propagation rate constant () relative to styrene, but offering excellent control over molecular weight distribution (PDI).^[3]
- p-BAMS Carbanion: The carbanion is less stabilized inductively.^{[1][2]} While resonance usually stabilizes anions, the electron-rich nature of the carbanion repels the lone-pair donation from the para-bromine.^[1] This destabilization can lead to higher reactivity in propagation but increased susceptibility to side reactions (e.g., termination via elimination).^[3]

“

Critical Consideration: Both monomers exhibit low ceiling temperatures (

C).[1][3] Polymerizations must be conducted at cryogenic temperatures (

C) to favor the forward reaction.[3]

Synthetic Utility: Lithiation & Cross-Coupling[5][6]

The bromine handle allows these monomers to serve as precursors for functionalized styrenes.

[1]

Lithium-Halogen Exchange[7]

- m-BAMS: Forms a thermodynamically more stable aryl lithium species.[1] The inductive withdrawal stabilizes the negative charge on the ring without the destabilizing electron-electron repulsion seen in para-resonance donors.[1]
 - Protocol Note: Exchange is rapid; however, the resulting m-lithio species is less prone to aggregation-induced precipitation than the p-isomer in non-polar solvents.[1]
- p-BAMS: The p-lithio species is less stable and more reactive.[1][2] It requires strict temperature control (
 - C) to prevent Wurtz-type coupling or polymerization of the vinyl group during the exchange.

Palladium-Catalyzed Coupling (Suzuki/Heck)[3]

- Oxidative Addition (Rate Determining Step): Electron-deficient aryl halides undergo oxidative addition to Pd(0) faster.[2][3]
 - Trend:m-BAMS > p-BAMS.[1]
 - Explanation: The higher value of the meta isomer renders the C-Br bond more susceptible to Pd insertion.[1]

- Heck Reaction: In Heck couplings, the electronic bias of the alkene matters.[1][2] Since the Br is on the aryl ring, it acts as the electrophile.[1] The meta-isomer generally provides higher yields in shorter reaction times due to the facilitated oxidative addition.[1]

Experimental Protocols

Protocol A: Anionic Polymerization (Representative)

Objective: Synthesis of poly(m-bromo-

-methylstyrene) with narrow PDI.[3]

- Purification: Distill m-BAMS from CaH

under reduced pressure. Final purification via titration with n-BuLi until a faint yellow color persists (scavenging impurities).[3]

- Solvent: THF (distilled from Na/benzophenone).
- Setup: Flame-dried Schlenk flask under Argon atmosphere.
- Initiation:
 - Cool THF (50 mL) to C.
 - Add sec-BuLi (0.1 mmol).
 - Add m-BAMS (10 mmol) dropwise.[3]
 - Observation: Rapid color change to deep red (characteristic of m-substituted benzyl carbanion).[3]
- Propagation: Stir at C for 4 hours.
- Termination: Quench with degassed methanol (2 mL).

- Isolation: Precipitate into excess methanol; filter and dry under vacuum.

Protocol B: Lithium-Halogen Exchange

Objective: Generation of

-methylstyryl-lithium nucleophiles.

- Solvent: Anhydrous THF/Hexane (1:1).
- Temperature: Cool to
C (Critical for p-BAMS to avoid polymerization).
- Exchange:
 - Add t-BuLi (2.1 equiv) dropwise to the BAMS solution.^{[1][3]}
 - Stir for 10 min at
C.
- Quench: Add electrophile (e.g., DMF, CO
) immediately.^{[2][3]}

Mechanistic Visualization

The following diagrams illustrate the electronic divergence and the polymerization pathway.

Diagram 1: Electronic Effects & Reactivity Flow

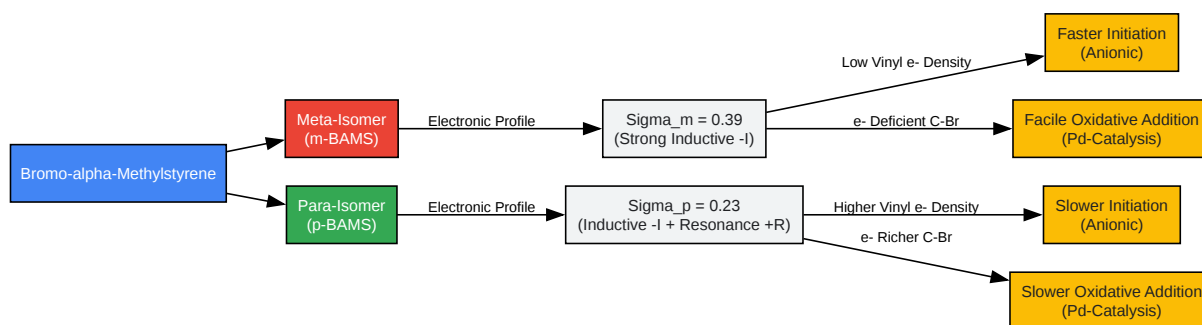

[Click to download full resolution via product page](#)

Caption: Divergence of reactivity based on Hammett substituent constants (

). Meta-substitution drives faster nucleophilic kinetics.[1]

Diagram 2: Anionic Polymerization Pathway

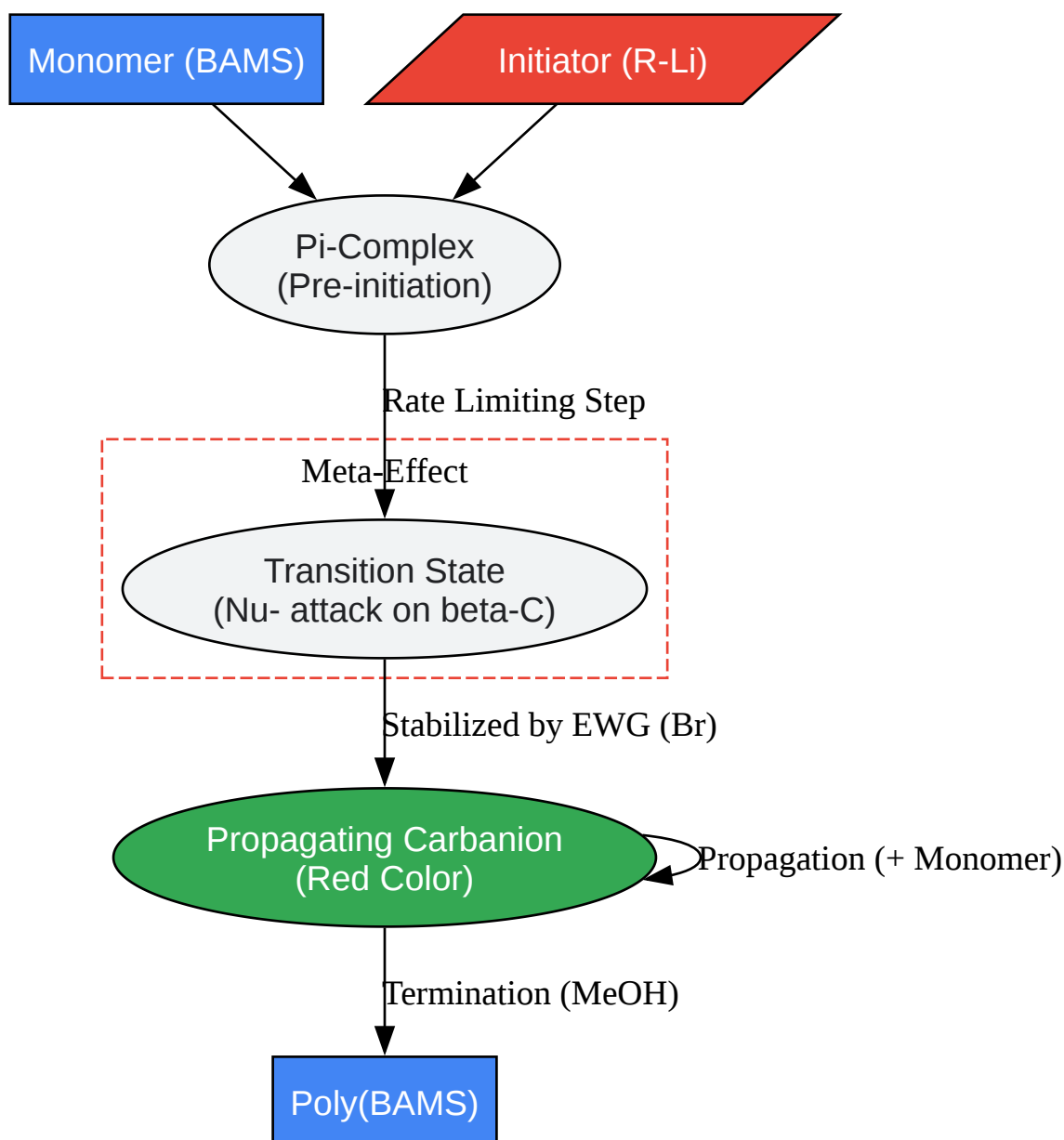

[Click to download full resolution via product page](#)

Caption: Anionic polymerization workflow. The transition state (TS) energy is lowered by the meta-bromo substituent, accelerating initiation.[3]

References

- Hansch, C., Leo, A., & Taft, R. W. (1991).[3] A Survey of Hammett Substituent Constants and Resonance and Field Parameters. *Chemical Reviews*, 91(2), 165–195.[3]

- Hsieh, H. L., & Quirk, R. P. (1996).[2][3] Anionic Polymerization: Principles and Practical Applications. Marcel Dekker.[2] (Standard Reference for Anionic Kinetics).
- Bailey, W. F., & Patricia, J. J. (1988).[2][3][4] The Mechanism of the Lithium-Halogen Exchange Reaction: A Review of the Literature. Journal of Organometallic Chemistry, 352(1-2), 1-46. [3]
- Miyaura, N., & Suzuki, A. (1995).[2][3] Palladium-Catalyzed Cross-Coupling Reactions of Organoboron Compounds. Chemical Reviews, 95(7), 2457–2483.[3]
- NIST Chemistry WebBook. (2023).[1][2][3]
-Methylstyrene Thermochemistry Data.

Need Custom Synthesis?

BenchChem offers custom synthesis for rare earth carbides and specific isotopic labeling.

Email: info@benchchem.com or [Request Quote Online](#).

Sources

- 1. [researchgate.net](https://www.researchgate.net) [[researchgate.net](https://www.researchgate.net)]
- 2. [researchgate.net](https://www.researchgate.net) [[researchgate.net](https://www.researchgate.net)]
- 3. [scispace.com](https://www.scispace.com) [[scispace.com](https://www.scispace.com)]
- 4. myers.faculty.chemistry.harvard.edu [myers.faculty.chemistry.harvard.edu]
- To cite this document: BenchChem. [Comparative Reactivity Guide: m-Bromo- vs. p-Bromo- -Methylstyrene]. BenchChem, [2026]. [Online PDF]. Available at: [<https://www.benchchem.com/product/b3034903/docs#comparative-reactivity-guide-m-bromo-vs-p-bromo-methylstyrene>]

Disclaimer & Data Validity:

The information provided in this document is for Research Use Only (RUO) and is strictly not intended for diagnostic or therapeutic procedures. While BenchChem strives to provide

accurate protocols, we make no warranties, express or implied, regarding the fitness of this product for every specific experimental setup.

Technical Support: The protocols provided are for reference purposes. Unsure if this reagent suits your experiment?

Need Industrial/Bulk Grade? [Request Custom Synthesis Quote](#)

BenchChem

Our mission is to be the trusted global source of essential and advanced chemicals, empowering scientists and researchers to drive progress in science and industry.

Contact

Address: 3281 E Guasti Rd

Ontario, CA 91761, United States

Phone: (601) 213-4426

Email: info@benchchem.com

[Contact our Ph.D. Support Team for a compatibility check](#)