

# Technical Deep Dive: Mass Spectrometry Fragmentation of 4-Chloropyrimidine-2- carbaldehyde

**Author:** BenchChem Technical Support Team. **Date:** May 2026

## Compound of Interest

Compound Name:	4-Chloropyrimidine-2-carbaldehyde
CAS No.:	944902-13-0
Cat. No.:	B3030705

[Get Quote](#)

## Executive Summary

**4-Chloropyrimidine-2-carbaldehyde** (CAS: 944902-13-0) is a critical heterocyclic scaffold used primarily as an intermediate in the synthesis of bioactive pharmaceuticals, including kinase inhibitors and antiviral agents.<sup>[1][2]</sup> Its structural duality—possessing an electrophilic aldehyde at C2 and a nucleophilic-susceptible chloride at C4—makes it highly reactive but also prone to specific fragmentation pathways in mass spectrometry (MS).<sup>[2][3]</sup>

This guide provides a comprehensive analysis of the MS behavior of **4-Chloropyrimidine-2-carbaldehyde**.<sup>[2]</sup> It details ionization characteristics, isotopic signatures, and mechanistic fragmentation pathways to assist researchers in structural validation and impurity profiling.<sup>[2][3]</sup>

## Physicochemical & Mass Spectral Profile

Property	Value	Notes
Formula	C <sub>5</sub> H <sub>3</sub> ClN <sub>2</sub> O	
Exact Mass (Monoisotopic)	141.9934 Da	Based on <sup>35</sup> Cl
Molecular Weight	142.54 Da	Average weight
Isotopic Pattern	M : M+2 (3:[2][4][5]1)	Diagnostic Chlorine signature
Nitrogen Rule	Even Mass	2 Nitrogens (Even) Even Nominal Mass
RDB Equivalents	5	1 Ring + 3 Double Bonds (Ring) + 1 Carbonyl

## The Chlorine Signature (Self-Validation)

The most reliable diagnostic tool for this molecule is the Chlorine Isotope Pattern. Natural chlorine exists as <sup>35</sup>Cl (75.8%) and <sup>37</sup>Cl (24.2%).[\[2\]\[3\]](#)

- Validation Check: In any mass spectrum (EI or ESI), the molecular ion cluster must exhibit a peak at m/z 142 (100% relative abundance) and m/z 144 (~32% relative abundance).
- Fragment Tracing: Any fragment ion retaining the chlorine atom will preserve this 3:1 intensity ratio.[\[2\]\[3\]](#) Fragments lacking this pattern have likely lost the halogen.[\[2\]\[3\]](#)

## Fragmentation Mechanics & Pathways[\[3\]\[6\]\[7\]\[8\]](#)

The fragmentation of **4-Chloropyrimidine-2-carbaldehyde** is driven by two competing instabilities: the labile carbonyl group (aldehyde) and the carbon-chlorine bond.

### Pathway A: Decarbonylation (Alpha-Cleavage/CO Loss)

Aromatic aldehydes readily lose carbon monoxide (CO) under Electron Ionization (EI) or Collision-Induced Dissociation (CID).[\[2\]\[3\]](#)

- Step 1: The molecular ion (m/z 142) undergoes  
-cleavage or rearrangement to eject a neutral CO molecule (28 Da).[\[2\]\[3\]\[6\]](#)

- Product: This yields the 4-chloropyrimidine radical cation at  $m/z$  114.[\[2\]](#)[\[3\]](#)
- Mechanism: The charge stabilizes on the pyrimidine ring nitrogens.[\[2\]](#)[\[3\]](#)

## Pathway B: Ring Fission (HCN Elimination)

Pyrimidine rings are characterized by the sequential loss of Hydrogen Cyanide (HCN, 27 Da).  
[\[3\]](#)

- Precursor: Typically occurs from the  $m/z$  114 fragment (post-CO loss).[\[2\]](#)[\[3\]](#)
- Step 1: The  $m/z$  114 ion ejects HCN.[\[2\]](#)[\[3\]](#)
- Product: A fragment at  $m/z$  87 ( $C_3H_2ClN$ ).
- Note: This fragment retains the chlorine, so the 3:1 isotope pattern persists.[\[2\]](#)[\[3\]](#)

## Pathway C: Dehalogenation (Radical/Neutral Loss)

Direct loss of the chlorine atom is less favorable than CO loss but occurs at higher collision energies.[\[3\]](#)

- Loss of  $Cl$ [\[2\]](#)[\[3\]](#) (35 Da): Yields  $m/z$  107 (Pyrimidine-2-carbaldehyde cation).[\[2\]](#)[\[3\]](#)
- Loss of  $HCl$  (36 Da): Yields  $m/z$  106.
- Observation: These peaks will lack the  $M+2$  isotope companion, confirming chlorine loss.[\[2\]](#)  
[\[3\]](#)

## Visualizing the Fragmentation Tree

The following diagram maps the logical flow of fragmentation, color-coded by ion type.

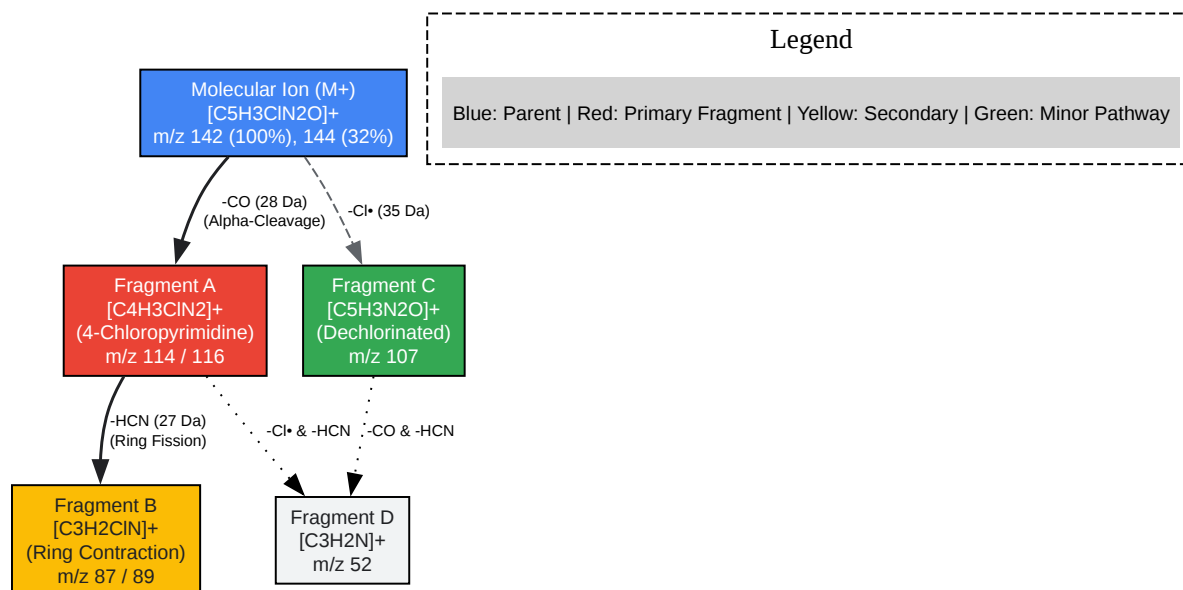

[Click to download full resolution via product page](#)

Caption: Logical fragmentation tree for **4-Chloropyrimidine-2-carbaldehyde** showing mass transitions and neutral losses.

## Experimental Protocol: Structural Validation

To confirm the identity of **4-Chloropyrimidine-2-carbaldehyde** in a synthesized batch or biological sample, follow this self-validating workflow.

### Sample Preparation

- Solvent: Acetonitrile (MeCN) or Methanol (MeOH).<sup>[2][3]</sup> Note: Aldehydes can form hemiacetals in MeOH; analyze immediately or use MeCN.
- Concentration: 1–10 µg/mL.<sup>[2][3]</sup>
- Additives: 0.1% Formic Acid (promotes protonation [M+H]<sup>+</sup> in ESI).<sup>[2][3]</sup>

## Instrument Parameters (LC-MS/MS)

- Ionization: Electrospray Ionization (ESI) - Positive Mode.[\[2\]](#)[\[3\]](#)
- Capillary Voltage: 3.0 – 3.5 kV.[\[2\]](#)[\[3\]](#)
- Cone Voltage: 20–40 V (Adjust to minimize in-source fragmentation of the aldehyde).
- Collision Energy (CID): Stepped 10–30 eV to observe both the molecular ion and fragments.

## Step-by-Step Data Analysis

- Locate the Parent: Look for m/z 143 ([M+H]<sup>+</sup>) in ESI or m/z 142 (M+[\[2\]](#)[\[3\]](#))<sup>•</sup> in EI.[\[2\]](#)[\[3\]](#)[\[7\]](#)[\[8\]](#)
- Verify Isotope Pattern: Confirm the M+2 peak exists at ~33% intensity of the parent.[\[2\]](#)[\[3\]](#)
  - If M+2 is missing: The compound is not chlorinated (check for dehalogenation byproducts).[\[2\]](#)[\[3\]](#)
- Check for Hemiacetals: If using methanol, look for m/z 175 (M + MeOH + H).[\[2\]](#)[\[3\]](#) This is a common artifact for aldehydes.[\[2\]](#)[\[3\]](#)
- Confirm CO Loss: Apply collision energy. The transition 143  
115 (ESI) or 142  
114 (EI) should be the dominant pathway.

## Summary of Diagnostic Ions

m/z (EI/Nominal)	Ion Identity	Mechanism of Formation	Isotope Pattern
142	Molecular Ion [M] <sup>+</sup> [2] <sup>•</sup>	Parent	Yes (3:1)
114	[M - CO] <sup>+</sup> [2] <sup>•</sup>	Loss of Carbonyl (Aldehyde specific)	Yes (3:1)
113	[M - CHO] <sup>+</sup>	Loss of Formyl Radical	Yes (3:1)
107	[M - Cl] <sup>+</sup>	Homolytic cleavage of C-Cl	No (Monoisotopic)
87	[114 - HCN] <sup>+</sup>	Ring fragmentation (Pyrimidine specific)	Yes (3:[2]1)
52	[C <sub>3</sub> H <sub>2</sub> N] <sup>+</sup>	Deep fragmentation (Loss of Cl, CO, HCN)	No

## References

- PubChem. (2025).[2][3] 4-Chloropyrimidine - Compound Summary. National Library of Medicine.[2][3] Available at: [\[Link\]](#)[2]
- Salem, M. A. I., et al. (2014).[2][3][7] Mass Spectral Fragmentation Modes of Some New Pyrimidinethiones. International Journal of Materials and Chemistry. Available at: [\[Link\]](#)
- NIST Mass Spectrometry Data Center. (2023).[2][3] 2,4-Dichloropyrimidine Mass Spectrum. National Institute of Standards and Technology.[2][3] Available at: [\[Link\]](#)[2]
- ChemGuide. (2023).[2][3] Fragmentation Patterns in Mass Spectrometry. Available at: [\[Link\]](#) [2]

### Need Custom Synthesis?

BenchChem offers custom synthesis for rare earth carbides and specific isotopic labeling.

Email: [info@benchchem.com](mailto:info@benchchem.com) or [Request Quote Online](#).

## Sources

- [1. alchempharmtech.com](https://alchempharmtech.com) [[alchempharmtech.com](https://alchempharmtech.com)]
- [2. 4-Chloropyrimidine | C4H3ClN2 | CID 642834 - PubChem](https://pubchem.ncbi.nlm.nih.gov/compound/4-Chloropyrimidine) [[pubchem.ncbi.nlm.nih.gov](https://pubchem.ncbi.nlm.nih.gov/compound/4-Chloropyrimidine)]
- [3. 2,4-Dichloropyrimidine | C4H2Cl2N2 | CID 77531 - PubChem](https://pubchem.ncbi.nlm.nih.gov/compound/2,4-Dichloropyrimidine) [[pubchem.ncbi.nlm.nih.gov](https://pubchem.ncbi.nlm.nih.gov/compound/2,4-Dichloropyrimidine)]
- [4. mdpi.com](https://mdpi.com) [[mdpi.com](https://mdpi.com)]
- [5. CN103554036B - The preparation method of a kind of 2-chloro-4-substituted pyrimidines compounds - Google Patents](https://patents.google.com/patent/CN103554036B) [[patents.google.com](https://patents.google.com/patent/CN103554036B)]
- [6. pubs.acs.org](https://pubs.acs.org) [[pubs.acs.org](https://pubs.acs.org)]
- [7. article.sapub.org](https://article.sapub.org) [[article.sapub.org](https://article.sapub.org)]
- [8. govinfo.gov](https://govinfo.gov) [[govinfo.gov](https://govinfo.gov)]
- To cite this document: BenchChem. [Technical Deep Dive: Mass Spectrometry Fragmentation of 4-Chloropyrimidine-2-carbaldehyde]. BenchChem, [2026]. [Online PDF]. Available at: [<https://www.benchchem.com/product/b3030705/docs#technical-deep-dive-mass-spectrometry-fragmentation-of-4-chloropyrimidine-2-carbaldehyde>]

---

### Disclaimer & Data Validity:

The information provided in this document is for Research Use Only (RUO) and is strictly not intended for diagnostic or therapeutic procedures. While BenchChem strives to provide accurate protocols, we make no warranties, express or implied, regarding the fitness of this product for every specific experimental setup.

**Technical Support:** The protocols provided are for reference purposes. Unsure if this reagent suits your experiment?

**Need Industrial/Bulk Grade?** [Request Custom Synthesis Quote](#)

# BenchChem

Our mission is to be the trusted global source of essential and advanced chemicals, empowering scientists and researchers to drive progress in science and industry.

## Contact

Address: 3281 E Guasti Rd

Ontario, CA 91761, United States

Phone: (601) 213-4426

Email: [info@benchchem.com](mailto:info@benchchem.com)

[Contact our Ph.D. Support Team for a compatibility check](#)