

# Part 1: Molecular Architecture and Fundamental Properties

**Author:** BenchChem Technical Support Team. **Date:** April 2026

## Compound of Interest

Compound Name:	2,7-Bis(carbazol-9-yl)-9,9-spirobifluorene
CAS No.:	924899-38-7
Cat. No.:	B3030586

[Get Quote](#)

The intrinsic characteristics of a host material are dictated by its molecular structure. The differences between CBP and 2,7-Cz-Spiro begin at this fundamental level, influencing everything from thermal stability to charge transport.

**CBP (4,4'-bis(N-carbazolyl)-1,1'-biphenyl):** A Biphenyl-Carbazole System CBP features two electron-rich carbazole units attached to a central biphenyl core.<sup>[1]</sup> This structure provides good hole mobility, making it an effective host. However, the rotational freedom around the single bonds in the biphenyl core results in a relatively low glass transition temperature (T<sub>g</sub>). This lower thermal stability can lead to morphological changes in the thin film during device operation, ultimately limiting the device's lifetime.

**2,7-Cz-Spiro (2,7-bis(carbazol-9-yl)-9,9-spirobifluorene):** A Rigid Spiro-Core Spiro compounds are characterized by a central atom that is a common member of two rings.<sup>[2][3]</sup> In 2,7-Cz-Spiro, this central spiro-carbon atom creates a rigid, three-dimensional, and sterically hindered structure. This molecular rigidity is the key to its significantly higher thermal stability compared to CBP.<sup>[4]</sup> This enhanced morphological stability is crucial for achieving long operational lifetimes in OLEDs.<sup>[4]</sup>

The table below summarizes the key physicochemical properties of these two host materials.

Property	2,7-Cz-Spiro (and close analogs)	CBP	Rationale for Importance
Glass Transition Temp. (Tg)	>150 °C[4]	~110 °C	Higher Tg indicates better morphological stability of the thin film, leading to longer device lifetimes.
Triplet Energy (ET)	~2.7-2.9 eV	~2.6 eV[1]	The host's triplet energy must be higher than the dopant's to prevent back energy transfer and confine excitons on the emitter.
HOMO Level	~-5.0 to -5.8 eV[5][6]	~-6.0 eV[1]	A higher HOMO level (closer to vacuum) reduces the energy barrier for hole injection from the hole transport layer (HTL).
LUMO Level	~-1.8 to -2.7 eV[6]	~-2.9 eV[1]	The LUMO level alignment affects electron injection from the electron transport layer (ETL) and charge balance.

## Part 2: Performance in Phosphorescent OLEDs

Experimental data from fabricated devices provide the ultimate verdict on a material's efficacy. Studies consistently show that spiro-based hosts like 2,7-Cz-Spiro and its derivatives outperform CBP.

In a comparative study, an orange-red PhOLED using a spiro-based host, 2,7-bis(carbazol-9-yl)-9,9-ditolyfluorene (Spiro-2CBP), achieved a current efficiency of over 44 cd/A.[5] In contrast, the device using a conventional CBP host reached only 30 cd/A under similar conditions.[6] The improved performance was attributed to the superior hole injection from the HTL into the spiro host, which has a higher HOMO level (-5.0 eV) compared to CBP (-6.0 eV), resulting in a negligible injection barrier.[5][6]

Similarly, another study using 4,4'-bis(N-carbazolyl)-9,9'-spirobifluorene (an isomer of 2,7-Cz-Spiro) as the host demonstrated both higher efficiency and a longer operational lifetime compared to an equivalent device using CBP.[4] The enhanced lifetime is a direct consequence of the higher thermal and morphological stability conferred by the spiro-core.[4]

## Part 3: Causality and Mechanistic Insights

The superior performance of 2,7-Cz-Spiro is not accidental; it is a direct result of its molecular design, which optimizes charge injection, transport, and exciton confinement.

### Charge Injection and Balance

Efficient light emission requires a balanced population of holes and electrons recombining within the emissive layer. As illustrated in the energy level diagram below, the HOMO level of CBP is significantly deeper (-6.0 eV) than that of typical hole transport materials like TAPC (-5.5 eV). ~~This creates a substantial energy barrier for holes to enter the emissive layer. In contrast, the higher HOMO level of 2,7-Cz-Spiro (-5.7 eV) or its analogs like Spiro-2CBP (-5.0 eV)~~ provides a much better energy alignment, facilitating efficient hole injection.[5][6] This improved hole injection leads to a more balanced charge carrier ratio in the emissive zone, boosting recombination efficiency.

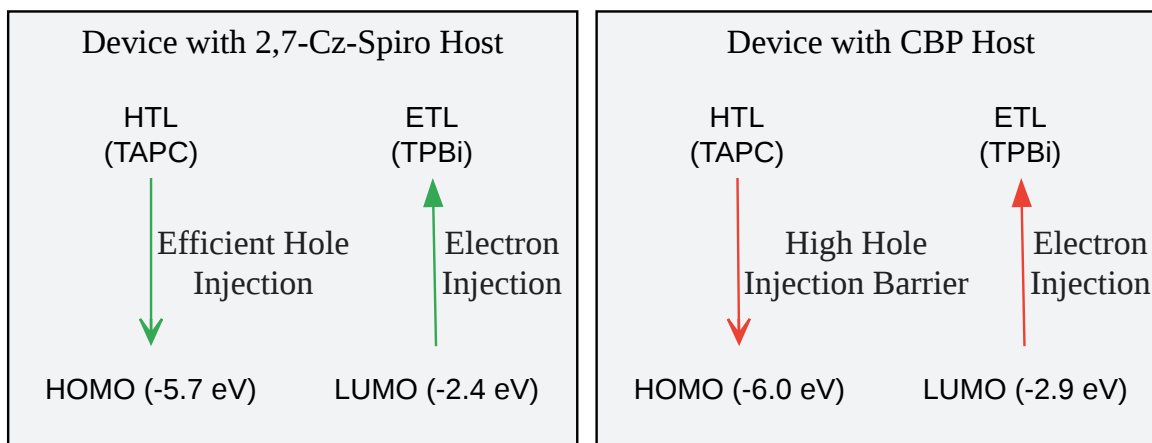

[Click to download full resolution via product page](#)

Caption: Energy level alignment showing improved hole injection for 2,7-Cz-Spiro compared to CBP.

## Exciton Confinement and Thermal Stability

For phosphorescent emitters, the host material must have a higher triplet energy (ET) than the emitter to effectively "confine" the triplet excitons and prevent energy loss. While both materials have sufficiently high ET for green and red emitters, the rigid spiro-structure is less prone to non-radiative decay pathways, contributing to higher overall efficiency. More importantly, the high T<sub>g</sub> of 2,7-Cz-Spiro prevents the material from softening and deforming under the heat generated during device operation, ensuring the long-term integrity of the device stack and a longer operational lifetime.[4]

## Part 4: Experimental Workflow

To validate these comparisons, devices must be fabricated and tested under controlled conditions. The following outlines a standard protocol for the fabrication of a multilayer PhOLED via thermal evaporation.

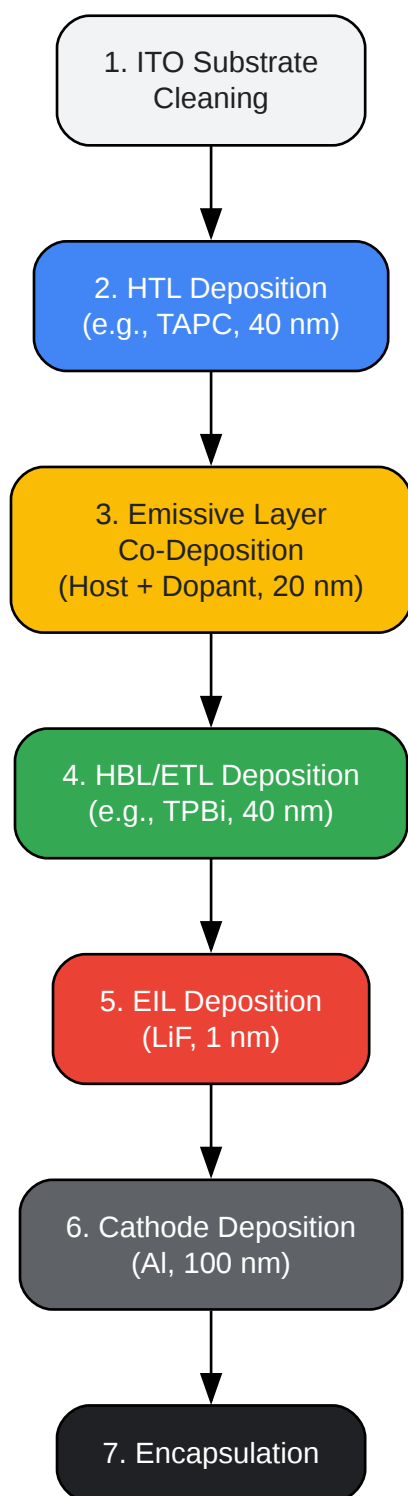

[Click to download full resolution via product page](#)

Caption: Standardized workflow for vacuum thermal evaporation of a phosphorescent OLED.

Step-by-Step Methodology:

- **Substrate Preparation:** Indium tin oxide (ITO)-coated glass substrates are cleaned sequentially in ultrasonic baths of detergent, deionized water, acetone, and isopropanol. They are then dried and treated with UV-ozone to increase the ITO work function and improve hole injection.
- **Layer Deposition:** All organic layers and the cathode are deposited in a high-vacuum thermal evaporation system (pressure < 10<sup>-6</sup> Torr).
  - **Hole Transport Layer (HTL):** 40 nm of TAPC is deposited.
  - **Emissive Layer (EML):** The host material (either CBP or 2,7-Cz-Spiro) is co-evaporated with a phosphorescent dopant (e.g., Ir(ppy)<sub>3</sub> for green emission) at a predetermined concentration (e.g., 6-10 wt%).
  - **Hole Blocking/Electron Transport Layer (HBL/ETL):** 40 nm of TPBi is deposited to block holes from reaching the cathode and to transport electrons.
  - **Electron Injection Layer (EIL):** A thin (1 nm) layer of LiF is deposited to lower the electron injection barrier.
  - **Cathode:** 100 nm of Aluminum (Al) is deposited as the top electrode.
- **Encapsulation:** The completed device is immediately transferred to a nitrogen-filled glovebox and encapsulated using a glass lid and UV-cured epoxy to prevent degradation from atmospheric moisture and oxygen.

## Conclusion and Outlook

While CBP has been an invaluable material in the development of OLEDs, the evidence strongly supports the superiority of 2,7-Cz-Spiro and related spiro-configured hosts for high-performance phosphorescent devices. The key advantages of 2,7-Cz-Spiro are its rigid molecular structure, which imparts excellent thermal stability for longer lifetimes, and its favorable HOMO energy level, which allows for more efficient, barrier-free hole injection. These intrinsic properties translate directly into OLEDs with higher efficiencies and greater operational stability. As the industry pushes for more demanding applications, the rational design of host materials with stable, three-dimensional architectures like 2,7-Cz-Spiro will continue to be a critical strategy for advancing OLED technology.

## References

- Bicarbazole-Benzophenone Based Twisted Donor-Acceptor Derivatives as Potential Blue TADF Emitters for OLEDs. National Center for Biotechnology Information. [[Link](#)]
- Highly efficient and stable organic light-emitting diode using 4,4'-bis(N-carbazolyl)-9,9'-spirobifluorene as a thermally stable host material. AIP Publishing. [[Link](#)]
- Highly efficient and stable deep-blue OLEDs based on narrowband emitters featuring an orthogonal spiro-configured indolo[3,2,1-de]acridine structure. National Center for Biotechnology Information. [[Link](#)]
- Novel oligo-9,9'-spirobifluorenes through ortho-linkage as full hydrocarbon host for highly efficient phosphorescent OLEDs. PubMed. [[Link](#)]
- Spirobifluorene-2,7-dicarbazole-4'-phosphine Oxide as Host for High-Performance Single-Layer Green Phosphorescent OLED Devices. ResearchGate. [[Link](#)]
- Highly efficient (EQE > 27%) Yellow OLEDs using spiro[fluorene-9,9'-phenanthren-10'-one]-carbazole-based donor-acceptor-donor host materials. RSC Publishing. [[Link](#)]
- Highly efficient orange-red phosphorescent organic light-emitting diode using 2,7-bis(carbazol-9-yl)-9,9-ditolylfluorene as the host. ResearchGate. [[Link](#)]
- Spiro-type host materials with rigidified skeletons for RGB phosphorescent OLEDs. RSC Publishing. [[Link](#)]
- Spirobifluorene-2,7-dicarbazole-4'-phosphine Oxide as Host for High-Performance Single-Layer Green Phosphorescent OLED Devices - Organic Letters. Figshare. [[Link](#)]
- C1-substituted bipolar spiro host for high-performance organic light-emitting diodes. RSC Publishing. [[Link](#)]
- (a) Current density and (b) luminance results of the Spiro-2CBP-... ResearchGate. [[Link](#)]
- Multilayer OLEDs. Performances of the devices using CzPA and CBP as... ResearchGate. [[Link](#)]

- Efficient deep-blue fluorescent material serving as emitter and host for high-performance organic light-emitting diodes. Journal of Electronic Materials. [\[Link\]](#)
- Spiro compound. Wikipedia. [\[Link\]](#)
- Discovery of Spiro Oxazolidinediones as Selective, Orally Bioavailable Inhibitors of p300/CBP Histone Acetyltransferases. ACS Publications. [\[Link\]](#)
- Status and Challenges of Blue OLEDs: A Review. National Center for Biotechnology Information. [\[Link\]](#)
- Structure of the spiro heterocycle [2.7.0] compound B1. ResearchGate. [\[Link\]](#)

#### Need Custom Synthesis?

BenchChem offers custom synthesis for rare earth carbides and specific isotopic labeling.

Email: [info@benchchem.com](mailto:info@benchchem.com) or [Request Quote Online](#).

## Sources

- [1. ossila.com](https://ossila.com) [[ossila.com](https://ossila.com)]
- [2. Spiro compound - Wikipedia](https://en.wikipedia.org) [[en.wikipedia.org](https://en.wikipedia.org)]
- [3. researchgate.net](https://researchgate.net) [[researchgate.net](https://researchgate.net)]
- [4. pubs.aip.org](https://pubs.aip.org) [[pubs.aip.org](https://pubs.aip.org)]
- [5. researchgate.net](https://researchgate.net) [[researchgate.net](https://researchgate.net)]
- [6. researchgate.net](https://researchgate.net) [[researchgate.net](https://researchgate.net)]
- To cite this document: BenchChem. [Part 1: Molecular Architecture and Fundamental Properties]. BenchChem, [2026]. [Online PDF]. Available at: [<https://www.benchchem.com/product/b3030586/docs#part-1-molecular-architecture-and-fundamental-properties>]

---

#### Disclaimer & Data Validity:

The information provided in this document is for Research Use Only (RUO) and is strictly not intended for diagnostic or therapeutic procedures. While BenchChem strives to provide accurate protocols, we make no warranties, express or implied, regarding the fitness of this product for every specific experimental setup.

**Technical Support:** The protocols provided are for reference purposes. Unsure if this reagent suits your experiment?

**Need Industrial/Bulk Grade?** [Request Custom Synthesis Quote](#)

## BenchChem

Our mission is to be the trusted global source of essential and advanced chemicals, empowering scientists and researchers to drive progress in science and industry.

### Contact

Address: 3281 E Guasti Rd  
Ontario, CA 91761, United States  
Phone: (601) 213-4426  
Email: [info@benchchem.com](mailto:info@benchchem.com)

[Contact our Ph.D. Support Team for a compatibility check](#)