

Technical Support Center: Minimizing Self-Polymerization of Amino-Aldehydes During Storage

Author: BenchChem Technical Support Team. **Date:** April 2026

Compound of Interest

Compound Name:	3-Amino-1,2-benzoxazole-5-carbaldehyde
CAS No.:	648449-67-6
Cat. No.:	B3029402

[Get Quote](#)

Welcome to the Technical Support Center for the handling and storage of amino-aldehydes. This guide is designed for researchers, scientists, and drug development professionals who work with these reactive molecules. The inherent instability of amino-aldehydes, arising from the presence of both a nucleophilic amine and an electrophilic aldehyde within the same molecule, presents significant challenges in their storage and use.^[1] This resource provides in-depth technical guidance, troubleshooting protocols, and frequently asked questions to help you mitigate self-polymerization and ensure the integrity of your experiments.

Frequently Asked Questions (FAQs)

Q1: What is amino-aldehyde self-polymerization and why does it occur?

A1: Amino-aldehyde self-polymerization is a reaction where individual amino-aldehyde molecules react with each other to form larger chains or cyclic structures. This occurs because the amine group of one molecule can act as a nucleophile and attack the electrophilic carbonyl carbon of the aldehyde group on another molecule.^{[1][2]} This initial reaction can lead to the

formation of imines, which can then undergo further reactions, leading to a complex mixture of oligomers and polymers.[3][4] This process is often referred to as aldol condensation.[5][6]

Q2: What are the visible signs of self-polymerization in my amino-aldehyde sample?

A2: The most common visual indicators of self-polymerization include the formation of a precipitate or solid material in what was once a clear solution.[7] You may also observe a change in color or an increase in the viscosity of the solution.[7] For more quantitative analysis, techniques like Nuclear Magnetic Resonance (NMR) spectroscopy or High-Performance Liquid Chromatography (HPLC) can be used to detect the appearance of new peaks corresponding to oligomeric or polymeric species.[7][8][9]

Q3: How do storage temperature and pH affect the stability of amino-aldehydes?

A3: Both temperature and pH are critical factors.

- **Temperature:** Lower temperatures significantly slow down the rate of self-polymerization. For many amino-aldehydes, storage at -20°C is recommended to minimize degradation.[10] Some highly unstable compounds may even require storage at -80°C.[11][12]
- **pH:** The pH of the solution can have a dramatic effect on the rate of polymerization. Generally, both acidic and basic conditions can catalyze the reaction. The optimal pH for stability is often near neutral, but this can be compound-specific.[13][14] For instance, at a low pH, the amine group is protonated, reducing its nucleophilicity, while at a high pH, the aldehyde can be more susceptible to attack.[15]

Q4: Are there any chemical additives that can help stabilize my amino-aldehyde?

A4: Yes, certain stabilizers can be added to inhibit polymerization. These can include:

- **Antioxidants:** To prevent oxidation, which can sometimes initiate polymerization.[16]
- **Radical Scavengers:** To quench any free radicals that might promote polymerization.
- **pH Buffers:** To maintain the optimal pH for stability.

- **Specific Inhibitors:** In some cases, small molecules can be added to reversibly block the reactive groups. For example, a patent describes the use of a combination of a phenolic compound and an amine to stabilize certain aldehydes.[\[16\]](#)

Troubleshooting Guide

This section addresses specific issues you might encounter and provides actionable solutions.

Issue 1: Rapid Precipitation or Cloudiness Observed in the Stored Sample

Potential Cause	Explanation	Troubleshooting Steps & Solutions
Inappropriate Storage Temperature	Higher temperatures accelerate the kinetics of the self-polymerization reaction.	Solution: Immediately transfer the amino-aldehyde to a lower temperature environment, such as a -20°C or -80°C freezer. For future storage, always consult the manufacturer's recommendation or literature for the optimal temperature. [10]
Incorrect pH	The pH of the solution may have drifted into a range that catalyzes polymerization. [13]	Solution: If possible, adjust the pH to a more neutral range using a suitable buffer system. It is crucial to ensure the buffer itself does not react with the amino-aldehyde.
High Concentration	The rate of polymerization is often concentration-dependent. Higher concentrations increase the likelihood of intermolecular reactions.	Solution: If the experimental protocol allows, dilute the amino-aldehyde stock solution before storage. Prepare smaller, single-use aliquots to avoid repeated freeze-thaw cycles of a concentrated stock. [7]
Presence of Impurities	Catalytic impurities, such as trace metals or other reactive species, can initiate or accelerate polymerization.	Solution: Ensure that all solvents and reagents used are of high purity. If feasible, purify the amino-aldehyde before storage using an appropriate technique like flash chromatography.

Issue 2: Inconsistent or Non-Reproducible Experimental Results

Potential Cause	Explanation	Troubleshooting Steps & Solutions
Partial Polymerization	Even without visible precipitation, some degree of oligomerization may have occurred, reducing the concentration of the active monomer.	Solution: Before use, analyze the amino-aldehyde solution using a technique like HPLC or NMR to confirm its purity and concentration.[7][8][9] Prepare fresh solutions from a solid sample if significant degradation is detected.
Degradation During Handling	Leaving the amino-aldehyde at room temperature for extended periods during experimental setup can lead to degradation.	Solution: Minimize the time the amino-aldehyde is at room temperature. Use an ice bath to keep the sample cool during preparation.[7]
Reaction with Solvents or Other Reagents	The amino-aldehyde may be reacting with the solvent or other components in the reaction mixture.	Solution: Verify the compatibility of the amino-aldehyde with all solvents and reagents. Consider using a less reactive solvent or protecting groups if necessary.

Experimental Protocols

Protocol 1: Recommended General Storage Procedure for Amino-Aldehydes

- **Purification:** If the amino-aldehyde is synthesized in-house, ensure it is purified to the highest possible degree to remove any catalytic impurities.
- **Solvent Selection:** If storing in solution, choose a high-purity, anhydrous, and unreactive solvent. Acetonitrile or anhydrous toluene are often suitable choices.[1][7]

- **Inert Atmosphere:** To prevent oxidation, which can sometimes precede polymerization, it is highly recommended to store the amino-aldehyde under an inert atmosphere (e.g., nitrogen or argon).[10][17]
- **Aliquoting:** Divide the amino-aldehyde into small, single-use aliquots in appropriate vials. This minimizes the number of freeze-thaw cycles and reduces the risk of contamination.[7]
- **Low Temperature Storage:** Store the aliquots at the lowest recommended temperature, typically -20°C or -80°C , and protect them from light.[7][10]

Protocol 2: Monitoring Amino-Aldehyde Stability by HPLC

- **Standard Preparation:** Prepare a fresh, known concentration standard of the amino-aldehyde.
- **Sample Preparation:** Dilute a small amount of the stored amino-aldehyde sample to a concentration within the linear range of the HPLC detector.
- **Chromatographic Conditions:** Use a suitable reversed-phase HPLC column and a mobile phase that provides good separation of the monomer from potential oligomers. A gradient elution may be necessary.
- **Analysis:** Inject both the standard and the sample. Compare the chromatograms. A decrease in the peak area of the monomer and the appearance of new, broader peaks at different retention times are indicative of polymerization.[7]

Visualization of the Self-Polymerization Process

The following diagram illustrates the initial step of amino-aldehyde self-polymerization, leading to the formation of a dimer.

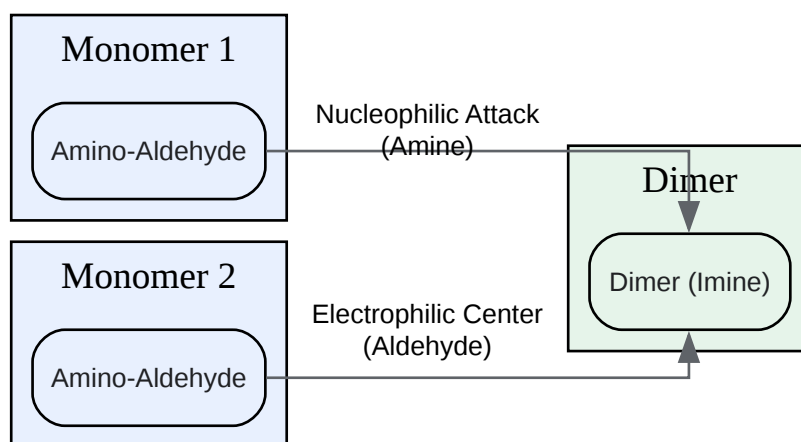

[Click to download full resolution via product page](#)

Caption: Initial dimerization of amino-aldehydes.

Key Factors Influencing Amino-Aldehyde Stability

Factor	Impact on Stability	Recommended Practice
Temperature	Lower temperature significantly reduces reaction rates.	Store at -20°C or -80°C.[10][11][12]
pH	Both acidic and basic conditions can catalyze polymerization.	Maintain a near-neutral pH or the empirically determined optimal pH.[13][14]
Concentration	Higher concentrations increase the probability of intermolecular reactions.	Store in dilute solutions or as a solid. Prepare single-use aliquots.[7]
Atmosphere	Oxygen can promote oxidative degradation, which may initiate polymerization.	Store under an inert atmosphere (Nitrogen or Argon).[10][17]
Purity	Impurities can act as catalysts.	Use high-purity solvents and reagents. Purify the amino-aldehyde if necessary.
Light	Light can provide the energy to initiate polymerization.	Store in amber vials or in the dark.[7]

Advanced Strategies for Stabilization

For particularly unstable amino-aldehydes, more advanced strategies may be required:

- **Protecting Groups:** The amine or aldehyde functionality can be temporarily protected with a chemical group that can be removed prior to use.^[18] For example, the amine can be protected as a carbamate, which reduces its nucleophilicity.^[18]
- **Dimerization:** In some cases, allowing the amino-aldehyde to form a stable, reversible dimer can prevent further polymerization.^[1] The monomer can then be regenerated from the dimer when needed.
- **Use of Stabilizers:** For certain aldehydes, specific stabilizers can be employed. For instance, a combination of a phenolic compound and an amine has been shown to be effective for some sulfur-containing aliphatic aldehydes.^[16]

By understanding the mechanisms of self-polymerization and implementing these storage and handling protocols, researchers can significantly improve the stability of their amino-aldehyde samples, leading to more reliable and reproducible experimental outcomes.

References

- Benchchem. (n.d.). Application Notes and Protocols for Safe Handling and Storage of Volatile Aldehydes.
- Benchchem. (n.d.). Best practices for handling and storing volatile aldehyde standards.
- Enantiomerically Pure α -Amino Aldehydes from Silylated α -Amino Acids. (n.d.). PMC.
- Stabilization of aldehydes. (n.d.). Google Patents.
- Unprotected Amino Aldehydes in Organic Synthesis. (n.d.).
- Benchchem. (n.d.). Strategies to minimize polymerization in Mannich reactions.
- Acetaldehyde. (n.d.).
- Method of stabilizing aldehydes. (n.d.). Google Patents.
- A kinetic and mechanistic study of the amino acid catalyzed aldol condensation of acetaldehyde in aqueous and salt solutions. (2008). PubMed.
- How Does pH Impact the Polymerization of Functional Monomers?. (2022, March 4). PCI Magazine.
- Studies of amino acids for inhibition of aldol condensation and dissolution of polymeric product of aldehyde in alkaline media. (2013, April 30). ResearchGate.

- Effect of pH on the Properties of Hydrogels Cross-Linked via Dynamic Thia-Michael Addition Bonds. (2021, December 28). ACS Polymers Au.
- Top Analytical Techniques for Characterizing Custom Polymers. (n.d.).
- Stability of amino acids and related amines in human serum under different preprocessing and pre-storage conditions based on iTRAQ. (n.d.). Journals Gateway | The Company of Biologists.
- Protecting Groups for Amines: Carbamates. (2018, June 7). Master Organic Chemistry.
- Temperature of frozen storage affects the nature and consequences of protein oxidation in beef patties. (n.d.). ResearchGate.
- What is the mechanism of the synthesis of amines from aldehydes?. (2017, April 16). Quora.
- Polymer Analysis: Essential Techniques and Strategies for Modern Laboratories. (n.d.).
- Aldehyde condensation polymer. (2026, January 21). Britannica.
- An Introduction to the Aldol Reaction (addition & condensation). (2025, April 15). Making Molecules.
- Reactions of Aldehydes and Ketones with Amines. (2014, September 4). Chemistry LibreTexts.

Need Custom Synthesis?

BenchChem offers custom synthesis for rare earth carbides and specific isotopic labeling.

Email: info@benchchem.com or [Request Quote Online](#).

Sources

- 1. utoronto.scholaris.ca [utoronto.scholaris.ca]
- 2. quora.com [quora.com]
- 3. pdf.benchchem.com [pdf.benchchem.com]
- 4. Aldehyde condensation polymer | Synthesis & Properties | Britannica [britannica.com]
- 5. researchgate.net [researchgate.net]
- 6. An Introduction to the Aldol Reaction (addition & condensation) — Making Molecules [makingmolecules.com]
- 7. pdf.benchchem.com [pdf.benchchem.com]
- 8. resolvemass.ca [resolvemass.ca]
- 9. sepscience.com [sepscience.com]

- [10. Enantiomerically Pure \$\alpha\$ -Amino Aldehydes from Silylated \$\alpha\$ -Amino Acids - PMC \[pmc.ncbi.nlm.nih.gov\]](#)
- [11. journals.biologists.com \[journals.biologists.com\]](#)
- [12. researchgate.net \[researchgate.net\]](#)
- [13. pcimag.com \[pcimag.com\]](#)
- [14. pubs.acs.org \[pubs.acs.org\]](#)
- [15. chem.libretexts.org \[chem.libretexts.org\]](#)
- [16. EP0096153A2 - Stabilization of aldehydes - Google Patents \[patents.google.com\]](#)
- [17. web.stanford.edu \[web.stanford.edu\]](#)
- [18. masterorganicchemistry.com \[masterorganicchemistry.com\]](#)
- To cite this document: BenchChem. [Technical Support Center: Minimizing Self-Polymerization of Amino-Aldehydes During Storage]. BenchChem, [2026]. [Online PDF]. Available at: [<https://www.benchchem.com/product/b3029402/docs#technical-support-center-minimizing-self-polymerization-of-amino-aldehydes-during-storage>]

Disclaimer & Data Validity:

The information provided in this document is for Research Use Only (RUO) and is strictly not intended for diagnostic or therapeutic procedures. While BenchChem strives to provide accurate protocols, we make no warranties, express or implied, regarding the fitness of this product for every specific experimental setup.

Technical Support: The protocols provided are for reference purposes. Unsure if this reagent suits your experiment?

Need Industrial/Bulk Grade? [Request Custom Synthesis Quote](#)

BenchChem

Our mission is to be the trusted global source of essential and advanced chemicals, empowering scientists and researchers to drive progress in science and industry.

Contact

Address: 3281 E Guasti Rd

Ontario, CA 91761, United States

Phone: (601) 213-4426

Email: info@benchchem.com

[Contact our Ph.D. Support Team for a compatibility check](#)