

Application and Protocol Guide: Advanced NMR Techniques for Isobenzofuranone Structure Confirmation

Author: BenchChem Technical Support Team. **Date:** January 2026

Compound of Interest

Compound Name: *5-phenoxyisobenzofuran-1(3H)-one*

Cat. No.: B3029204

[Get Quote](#)

For: Researchers, scientists, and drug development professionals

Introduction

Isobenzofuranones, also known as phthalides, represent a significant class of lactones that form the core scaffold of numerous natural products and pharmacologically active compounds. [1] Their diverse biological activities, ranging from antifungal and antibacterial to anticancer and insecticidal properties, make them a focal point in medicinal chemistry and drug discovery. [1] The precise and unambiguous determination of their molecular structure is a critical prerequisite for understanding their mechanism of action, establishing structure-activity relationships (SAR), and ensuring the viability of synthetic routes.

Nuclear Magnetic Resonance (NMR) spectroscopy stands as the most powerful and indispensable tool for the structural elucidation of organic molecules, including isobenzofuranones. [2][3][4] While basic one-dimensional (1D) NMR techniques like ^1H and ^{13}C NMR provide foundational information, the complexity of substituted isobenzofuranones often necessitates a more sophisticated, multi-dimensional approach for complete and accurate structure confirmation. [5][6] This guide provides a detailed overview and practical protocols for employing a suite of advanced 2D NMR techniques to confidently elucidate and confirm the structure of isobenzofuranone derivatives.

The Isobenzofuranone Scaffold: A Spectroscopic Overview

The fundamental isobenzofuranone structure presents a unique set of spectroscopic features. [7] Understanding the expected chemical shifts and coupling patterns is the first step in the elucidation process.

^1H and ^{13}C NMR: The Foundational Data

^1H NMR Spectroscopy: The proton NMR spectrum provides initial insights into the substitution pattern of the isobenzofuranone core. Key diagnostic signals include:

- **Aromatic Protons:** Typically resonate in the downfield region (δ 7.0-8.0 ppm) due to the deshielding effect of the benzene ring. [8][9][10] The multiplicity of these signals (doublets, triplets, etc.) reveals the substitution pattern on the aromatic ring.
- **Methylene Protons (-CH₂-O-):** The protons of the methylene group at position 3 (if unsubstituted) typically appear as a singlet around δ 5.0-5.5 ppm.
- **Methine Proton (-CH-O-):** If position 3 is substituted, the methine proton will exhibit a chemical shift that is highly dependent on the nature of the substituent. [11]

^{13}C NMR Spectroscopy: The carbon spectrum complements the proton data by revealing the carbon framework. [12][13] Characteristic signals for the isobenzofuranone core include:

- **Carbonyl Carbon (C=O):** The lactone carbonyl carbon is highly deshielded and appears significantly downfield, typically in the range of δ 168-172 ppm. [11]
- **Aromatic Carbons:** These carbons resonate in the δ 120-155 ppm region. [14] Quaternary aromatic carbons often have weaker signals.
- **Methylene/Methine Carbon (C3):** The carbon at position 3 will have a chemical shift around δ 70-85 ppm, influenced by the attached oxygen and any other substituents. [11][15]

Table 1: Typical ^1H and ^{13}C Chemical Shift Ranges for the Isobenzofuranone Core

Position	^1H Chemical Shift (δ , ppm)	^{13}C Chemical Shift (δ , ppm)
Carbonyl (C1)	-	168 - 172
Methylene (C3, unsubstituted)	~ 5.0 - 5.5	~ 70 - 80
Methine (C3, substituted)	Varies with substituent	~ 75 - 85
Aromatic (C4-C7)	~ 7.0 - 8.0	~ 120 - 140
Quaternary Aromatic (C3a, C7a)	-	~ 125 - 155

Note: These are approximate ranges and can vary based on substituents and solvent.[9][12]

The Power of 2D NMR: Assembling the Molecular Puzzle

For complex isobenzofuranone derivatives, 1D NMR spectra can be crowded and difficult to interpret. Two-dimensional (2D) NMR experiments are essential for unambiguously assigning signals and piecing together the molecular structure.[6][16]

Workflow for Isobenzofuranone Structure Elucidation using 2D NMR

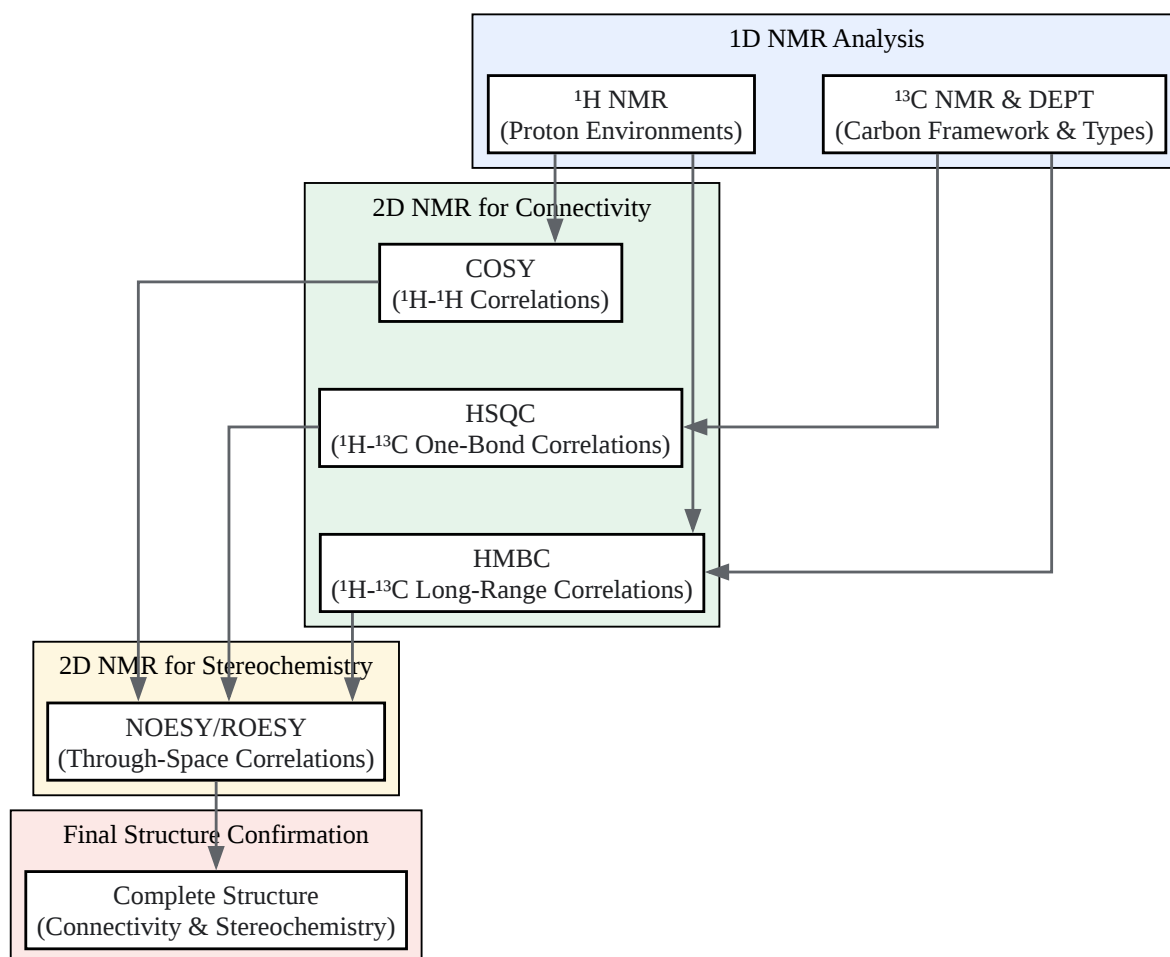

[Click to download full resolution via product page](#)

Caption: A typical workflow for isobenzofuranone structure elucidation using a suite of NMR experiments.

COSY (Correlation Spectroscopy): Identifying Spin Systems

The COSY experiment is the workhorse for establishing proton-proton (^1H - ^1H) coupling networks, typically over two or three bonds.^[6] In the context of isobenzofuranones, COSY is invaluable for:

- Mapping Aromatic Substituents: Tracing the connectivity of adjacent protons on the benzene ring to confirm the substitution pattern.
- Identifying Side Chains: Elucidating the structure of alkyl or other chains attached to the isobenzofuranone core.

HSQC (Heteronuclear Single Quantum Coherence): Linking Protons to Carbons

The HSQC experiment correlates proton signals with the signals of the carbons to which they are directly attached (one-bond ^1H - ^{13}C correlation).^{[6][17]} Its primary utility is in:

- Unambiguous Carbon Assignment: Directly assigning the chemical shift of a carbon atom based on the chemical shift of its attached proton(s).
- Resolving Overlapping Signals: Dispersing overlapping proton signals in the carbon dimension, aiding in their individual assignment.^[6]

HMBC (Heteronuclear Multiple Bond Correlation): Building the Carbon Skeleton

The HMBC experiment is arguably the most critical 2D NMR technique for elucidating the overall structure of complex molecules.^{[17][18]} It reveals correlations between protons and carbons that are separated by two or three bonds (and sometimes four in conjugated systems).^{[17][19][20]} For isobenzofuranones, HMBC is essential for:

- Connecting Fragments: Establishing connectivity between different spin systems that are separated by quaternary carbons or heteroatoms.

- Positioning Substituents: A key correlation from a proton on a substituent to a carbon on the isobenzofuranone core (or vice-versa) definitively places that substituent.
- Confirming the Core Structure: Correlations from the aromatic protons to the carbonyl carbon and the C3 carbon are crucial for confirming the isobenzofuranone scaffold.[21]

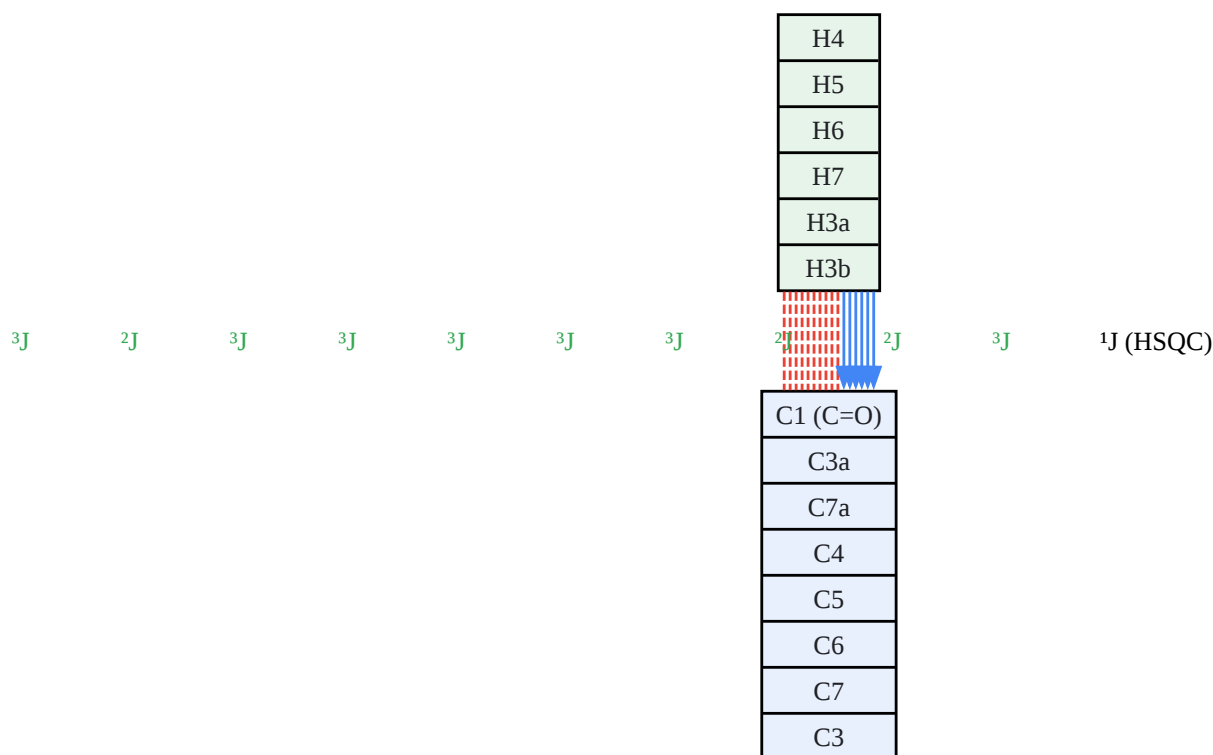

[Click to download full resolution via product page](#)

Caption: Key HMBC (dashed lines) and HSQC (solid lines) correlations for an unsubstituted isobenzofuranone.

NOESY/ROESY: Determining Stereochemistry and Conformation

For isobenzofuranones with stereocenters, determining the relative stereochemistry is crucial. NOESY (Nuclear Overhauser Effect Spectroscopy) and ROESY (Rotating-frame Overhauser Effect Spectroscopy) experiments provide this information by detecting correlations between protons that are close in space, regardless of their bonding connectivity.[22][23][24]

- NOESY: Ideal for small to large molecules. The intensity of a NOESY cross-peak is inversely proportional to the sixth power of the distance between the protons.
- ROESY: Particularly useful for medium-sized molecules where the NOE effect can be close to zero.

These experiments are critical for defining the spatial relationships between substituents and protons on the isobenzofuranone ring system.[23][24]

Experimental Protocols

Sample Preparation

- Sample Quantity: For a comprehensive suite of 2D NMR experiments on a modern spectrometer (≥ 400 MHz), aim for 5-10 mg of the purified isobenzofuranone. For highly sensitive instruments with cryoprobes, as little as 1 mg may be sufficient.
- Solvent Selection: Choose a deuterated solvent that fully dissolves the sample. Chloroform-d (CDCl_3) is a common first choice. Other options include acetone-d₆, methanol-d₄, or dimethyl sulfoxide-d₆ (DMSO-d₆).
- Sample Preparation: a. Weigh the sample accurately and dissolve it in approximately 0.6-0.7 mL of the chosen deuterated solvent in a clean vial. b. Filter the solution through a small plug of glass wool in a Pasteur pipette directly into a clean, dry NMR tube to remove any particulate matter. c. Add a small amount of tetramethylsilane (TMS) as an internal standard for chemical shift referencing ($\delta = 0.00$ ppm), if not already present in the solvent.

NMR Data Acquisition

The following are general acquisition parameters. These may need to be optimized based on the specific instrument, probe, and sample.

Table 2: Suggested NMR Acquisition Parameters

Experiment	Key Parameters	Typical Values	Purpose
¹ H NMR	Number of Scans (ns)	16-64	Improve signal-to-noise
	Relaxation Delay (d1)	1-2 s	
¹³ C NMR	Number of Scans (ns)	1024-4096	Overcome low natural abundance of ¹³ C
	Relaxation Delay (d1)	2 s	
COSY	Number of Increments	256-512	Determine resolution in the indirect dimension
	Number of Scans (ns)	2-8	
HSQC	¹ J(C,H) Coupling	145 Hz	Optimize for one-bond C-H coupling
	Number of Increments	128-256	
	Number of Scans (ns)	2-8	
HMBC	Long-Range Coupling	8 Hz	Optimize for 2-3 bond C-H couplings
	Number of Increments	256-512	
	Number of Scans (ns)	8-32	
NOESY	Mixing Time (d8)	500-800 ms	Allow for NOE buildup
	Number of Increments	256-512	
	Number of Scans (ns)	8-16	

Data Processing and Interpretation

- Processing: Apply appropriate window functions (e.g., exponential multiplication for sensitivity enhancement or sine-bell for resolution enhancement) and perform Fourier transformation in both dimensions. Phase and baseline correct all spectra carefully.
- Interpretation Strategy:
 - a. Assign Protonated Carbons: Use the HSQC spectrum to link each proton signal to its directly attached carbon.
 - b. Build Spin Systems: Use the COSY spectrum to connect protons that are coupled to each other, defining molecular fragments.
 - c. Connect the Fragments: Use the HMBC spectrum to piece together the fragments. Look for key correlations from protons to quaternary carbons and the carbonyl carbon.
 - d. Confirm Stereochemistry: Analyze the NOESY/ROESY spectrum for through-space correlations between protons to determine their relative spatial arrangement.
 - e. Final Check: Ensure that all observed correlations are consistent with the proposed structure and that all signals in the ^1H and ^{13}C spectra are fully assigned. In cases of ambiguity, theoretical calculations of NMR chemical shifts can be a powerful tool for validation.^{[1][25][26]}

Conclusion

The structural confirmation of isobenzofuranones relies on a systematic and multi-faceted NMR approach. While 1D NMR provides the initial overview, a combination of 2D NMR techniques—COSY, HSQC, HMBC, and NOESY/ROESY—is indispensable for unambiguous structure elucidation, particularly for novel or complex derivatives.^{[27][28][29]} By carefully acquiring, processing, and interpreting this suite of experiments, researchers can confidently determine the connectivity and stereochemistry of isobenzofuranones, paving the way for further investigation into their chemical and biological properties.

Need Custom Synthesis?

BenchChem offers custom synthesis for rare earth carbides and specific isotopic labeling.

Email: info@benchchem.com or [Request Quote Online](#).

References

1. Characterization of novel isobenzofuranones by DFT calculations and 2D NMR analysis - PubMed [pubmed.ncbi.nlm.nih.gov]

- 2. [researchgate.net](https://www.researchgate.net) [[researchgate.net](https://www.researchgate.net)]
- 3. [acdlabs.com](https://www.acdlabs.com) [[acdlabs.com](https://www.acdlabs.com)]
- 4. NMR Structure Elucidation of Natural Products and Synthesized Compounds in Nigeria - Europub [[europub.co.uk](https://www.europub.co.uk)]
- 5. ccc.chem.pitt.edu [ccc.chem.pitt.edu]
- 6. nmr.chem.ox.ac.uk [nmr.chem.ox.ac.uk]
- 7. 1(3H)-Isobenzofuranone [webbook.nist.gov]
- 8. NMR Chemical Shift Values Table - Chemistry Steps [[chemistrysteps.com](https://www.chemistrysteps.com)]
- 9. [compoundchem.com](https://www.compoundchem.com) [[compoundchem.com](https://www.compoundchem.com)]
- 10. chem.libretexts.org [chem.libretexts.org]
- 11. application.wiley-vch.de [application.wiley-vch.de]
- 12. [compoundchem.com](https://www.compoundchem.com) [[compoundchem.com](https://www.compoundchem.com)]
- 13. [youtube.com](https://www.youtube.com) [[youtube.com](https://www.youtube.com)]
- 14. ¹³C NMR Chemical Shift [sites.science.oregonstate.edu]
- 15. [spectrabase.com](https://www.spectrabase.com) [[spectrabase.com](https://www.spectrabase.com)]
- 16. eqnmr.hms.harvard.edu [eqnmr.hms.harvard.edu]
- 17. nmr.chem.columbia.edu [nmr.chem.columbia.edu]
- 18. chem.libretexts.org [chem.libretexts.org]
- 19. Unequivocal identification of two-bond heteronuclear correlations in natural products at nanomole scale by i-HMBC - PMC [pubmed.ncbi.nlm.nih.gov]
- 20. Long-range heteronuclear correlation [chem.ch.huji.ac.il]
- 21. [researchgate.net](https://www.researchgate.net) [[researchgate.net](https://www.researchgate.net)]
- 22. nmr.ceitec.cz [nmr.ceitec.cz]
- 23. [acdlabs.com](https://www.acdlabs.com) [[acdlabs.com](https://www.acdlabs.com)]
- 24. chem.libretexts.org [chem.libretexts.org]
- 25. [researchgate.net](https://www.researchgate.net) [[researchgate.net](https://www.researchgate.net)]
- 26. [researchgate.net](https://www.researchgate.net) [[researchgate.net](https://www.researchgate.net)]
- 27. api.pageplace.de [api.pageplace.de]
- 28. dl.iranchembook.ir [dl.iranchembook.ir]

- 29. wiley.com [wiley.com]
- To cite this document: BenchChem. [Application and Protocol Guide: Advanced NMR Techniques for Isobenzofuranone Structure Confirmation]. BenchChem, [2026]. [Online PDF]. Available at: [<https://www.benchchem.com/product/b3029204#nmr-techniques-for-isobenzofuranone-structure-confirmation>]

Disclaimer & Data Validity:

The information provided in this document is for Research Use Only (RUO) and is strictly not intended for diagnostic or therapeutic procedures. While BenchChem strives to provide accurate protocols, we make no warranties, express or implied, regarding the fitness of this product for every specific experimental setup.

Technical Support: The protocols provided are for reference purposes. Unsure if this reagent suits your experiment? [[Contact our Ph.D. Support Team for a compatibility check](#)]

Need Industrial/Bulk Grade? [Request Custom Synthesis Quote](#)

BenchChem

Our mission is to be the trusted global source of essential and advanced chemicals, empowering scientists and researchers to drive progress in science and industry.

Contact

Address: 3281 E Guasti Rd

Ontario, CA 91761, United States

Phone: (601) 213-4426

Email: info@benchchem.com