

# Technical Support Center: Managing Autofluorescence of Rutin Hydrate in Imaging Studies

**Author:** BenchChem Technical Support Team. **Date:** December 2025

## Compound of Interest

Compound Name: Rutin hydrate

Cat. No.: B3028452

[Get Quote](#)

This technical support center provides troubleshooting guides and frequently asked questions (FAQs) to help researchers, scientists, and drug development professionals address autofluorescence issues encountered during imaging studies involving **Rutin hydrate**.

## Frequently Asked Questions (FAQs)

Q1: What is autofluorescence and why is it a problem in imaging studies?

A: Autofluorescence is the natural emission of light by biological structures or compounds within cells and tissues when they are excited by light.<sup>[1]</sup> This intrinsic fluorescence can be a significant issue in fluorescence microscopy as it can mask the signal from the specific fluorescent probes you are using to label your target of interest, leading to a low signal-to-noise ratio and potentially erroneous results.<sup>[1]</sup> When imaging flavonoids like Rutin, some of these compounds themselves are inherently fluorescent, which can either be the signal of interest or a source of interference.<sup>[1][2]</sup>

Q2: What are the sources of autofluorescence in a typical experiment involving **Rutin hydrate**?

A: Autofluorescence can originate from several sources:

- **Endogenous Cellular Components:** Molecules like NADH, FAD, flavins, collagen, elastin, and lipofuscin (an age-related pigment) are common sources of autofluorescence.<sup>[1]</sup> Red blood cells also exhibit strong autofluorescence due to the presence of heme.

- **Rutin Hydrate** Itself: Rutin, as a flavonoid, can exhibit autofluorescence, which may interfere with the detection of other fluorophores.
- Experimental Reagents and Procedures:
  - Fixatives: Aldehyde fixatives like glutaraldehyde and formaldehyde are major contributors to autofluorescence by reacting with amines in tissues to form fluorescent products. Glutaraldehyde generally produces more autofluorescence than formaldehyde.
  - Cell Culture Media: Components like phenol red and Fetal Bovine Serum (FBS) can increase background fluorescence.

Q3: How can I determine if the fluorescence I am observing is from my specific label or from autofluorescence?

A: The most reliable way to identify autofluorescence is to prepare and image an unstained control sample. This control should undergo all the same processing steps as your experimental samples, including fixation and mounting, but without the addition of your fluorescent probe. Any signal detected from this unstained sample can be attributed to autofluorescence.

Q4: What are the spectral properties of **Rutin hydrate**'s autofluorescence?

A: The excitation and emission spectra of **Rutin hydrate** can vary depending on the solvent and its interaction with other molecules. However, studies have reported the following spectral characteristics:

Compound/Complex	Excitation Max ( $\lambda_{ex}$ )	Emission Max ( $\lambda_{em}$ )	Reference
Rutin trihydrate	260 nm	302 nm	
Rutin	380 nm	540 nm	
Rutin in methanol	~360 nm	415 nm	
Rutin-Yttrium complex	405 nm	490-600 nm	

This variability highlights the importance of characterizing the autofluorescence spectrum under your specific experimental conditions.

## Troubleshooting Guide

This guide provides a systematic approach to identifying and mitigating common issues related to **Rutin hydrate** autofluorescence.

Problem: High background fluorescence across the entire field of view.

This is a common issue that can often be addressed by optimizing your experimental protocol.

Potential Cause	Recommended Solution
Fixation-Induced Autofluorescence	<p>Minimize Fixation Time: Use the shortest fixation duration that still preserves the cellular morphology.</p> <p>Choose a Milder Fixative: Opt for paraformaldehyde over glutaraldehyde, as it tends to induce less autofluorescence.</p> <p>Chemical Quenching: After fixation, treat samples with a quenching agent like sodium borohydride or glycine to reduce aldehyde-induced fluorescence.</p>
Autofluorescence from Culture Media	<p>Use Phenol Red-Free Media: For live-cell imaging, switch to a culture medium that does not contain phenol red.</p> <p>Reduce Serum Concentration: Lower the concentration of Fetal Bovine Serum (FBS) or replace it with Bovine Serum Albumin (BSA), as FBS can be a source of autofluorescence.</p>
Endogenous Autofluorescence	<p>Perfusion: For tissue samples, perfuse with PBS prior to fixation to remove red blood cells, a major source of autofluorescence.</p> <p>Use Older Fluorophores: Select fluorophores that emit in the red to far-red region of the spectrum (620-750nm), as endogenous autofluorescence is often more prominent in the blue to green spectrum (350-550nm).</p> <p>Photobleaching: Intentionally expose the sample to intense light to "bleach" the autofluorescent molecules before imaging your target.</p>

Problem: Spectral overlap between **Rutin hydrate** autofluorescence and my fluorescent probe.

This issue requires more advanced techniques to separate the two signals.

Potential Cause	Recommended Solution
Broad Emission Spectrum of Rutin	<p><b>Spectral Unmixing:</b> This computational technique treats the autofluorescence as a separate "fluorophore" with its own unique spectral signature. By acquiring images across multiple emission wavelengths, specialized software can then mathematically separate the autofluorescence signal from your specific probe's signal.</p> <p><b>Choose Fluorophores with Narrow Spectra:</b> Select dyes with narrow excitation and emission peaks to minimize the chances of spectral overlap.</p>
Low Signal-to-Noise Ratio	<p><b>Use Brighter Fluorophores:</b> Employing brighter fluorophores can help to overwhelm the autofluorescence signal, improving the signal-to-noise ratio.</p> <p><b>Signal Amplification:</b> Techniques like tyramide signal amplification can be used to enhance the specific signal from your probe, making it more distinguishable from the background autofluorescence.</p>

## Experimental Protocols

### 1. Chemical Quenching of Aldehyde-Induced Autofluorescence with Sodium Borohydride

This protocol is designed to reduce autofluorescence caused by aldehyde-based fixatives.

- **Deparaffinize and Rehydrate:** If using paraffin-embedded tissues, deparaffinize sections in xylene and rehydrate through a graded ethanol series to water.
- **Antigen Retrieval:** Perform antigen retrieval if required for your antibody staining protocol.
- **Sodium Borohydride Incubation:** Prepare a fresh 0.1% solution of sodium borohydride in PBS.

- Incubate the tissue sections in the sodium borohydride solution for 10-15 minutes at room temperature. Some protocols suggest multiple incubations of 4-10 minutes each.
- Washing: Thoroughly wash the sections with PBS (3 times for 5 minutes each).
- Proceed with your standard blocking and immunofluorescence staining protocol.

## 2. Photobleaching to Reduce Autofluorescence

This method uses intense light to destroy autofluorescent molecules.

- Prepare Sample: Mount your fixed and coverslipped sample on the microscope stage.
- Select Objective: Use a high numerical aperture objective (e.g., 40x or 60x) to deliver a high intensity of light.
- Illuminate: Expose the area of interest to continuous, high-intensity light from the microscope's light source (e.g., mercury arc lamp). The duration of photobleaching can range from 15 minutes to several hours, depending on the sample and the intensity of the autofluorescence.
- Monitor: Periodically check the level of autofluorescence until it has been sufficiently reduced.
- Proceed with Imaging: Acquire images of your fluorescently labeled target.

## 3. Spectral Unmixing Workflow

This computational approach separates spectrally overlapping signals.

- Acquire a Reference Spectrum for Autofluorescence: Image an unstained control sample using the same settings as your experimental samples. This will capture the unique emission spectrum of the autofluorescence.
- Acquire Reference Spectra for Your Fluorophores: Image samples stained with each of your individual fluorophores to obtain their reference spectra.

- Acquire an Image of Your Stained Sample: Image your fully stained experimental sample, acquiring data across a range of emission wavelengths (a "lambda stack").
- Perform Linear Unmixing: Use imaging software with spectral unmixing capabilities (e.g., ZEN, LAS X, or ImageJ/Fiji with appropriate plugins). The software will use the reference spectra to mathematically calculate the contribution of each fluorophore and the autofluorescence to the final image, effectively separating them into different channels.

## Visualizations

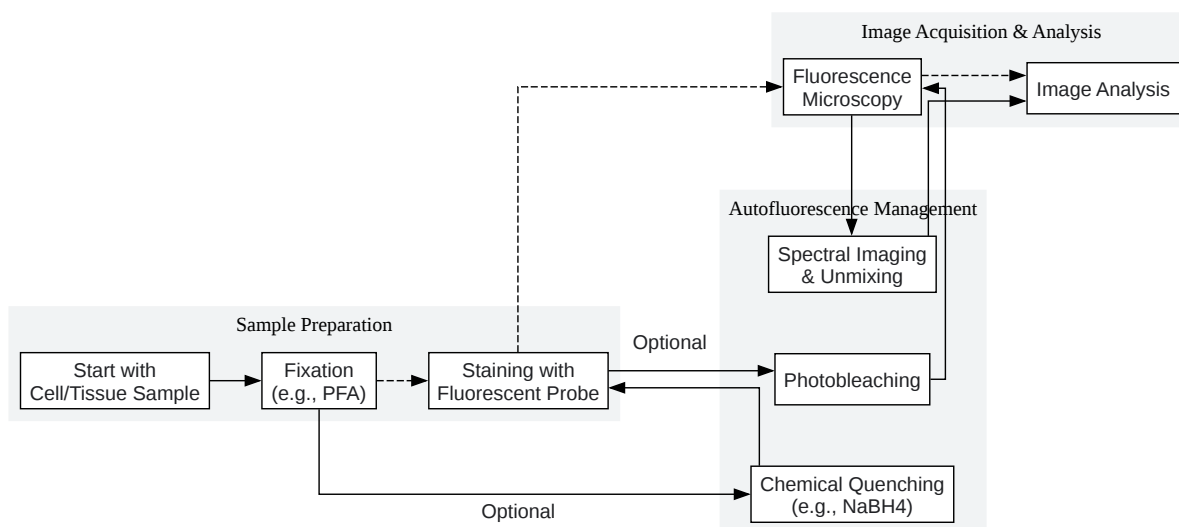

[Click to download full resolution via product page](#)

Caption: Experimental workflow for managing autofluorescence in imaging studies.

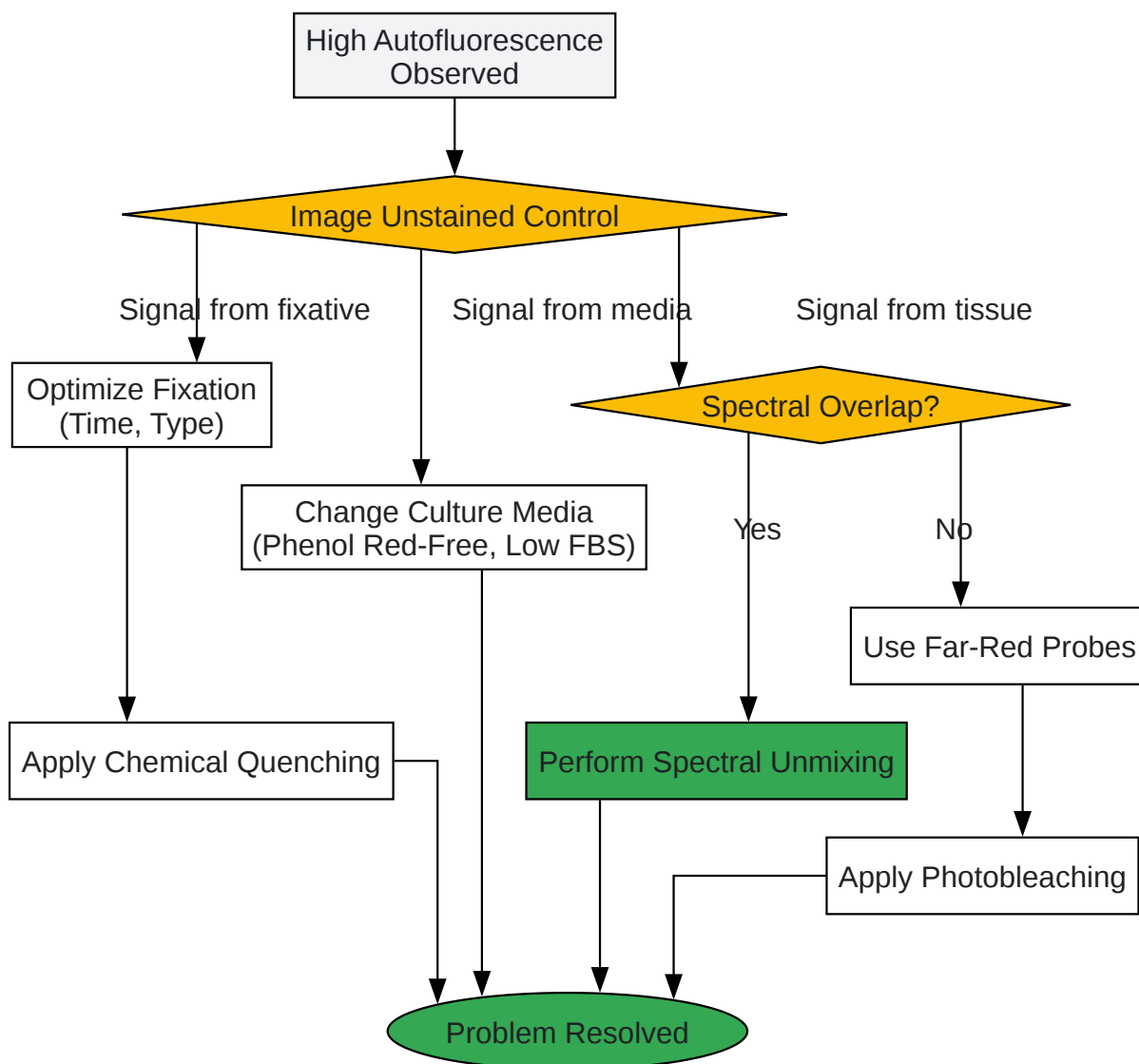

[Click to download full resolution via product page](#)

Caption: Troubleshooting flowchart for managing autofluorescence.



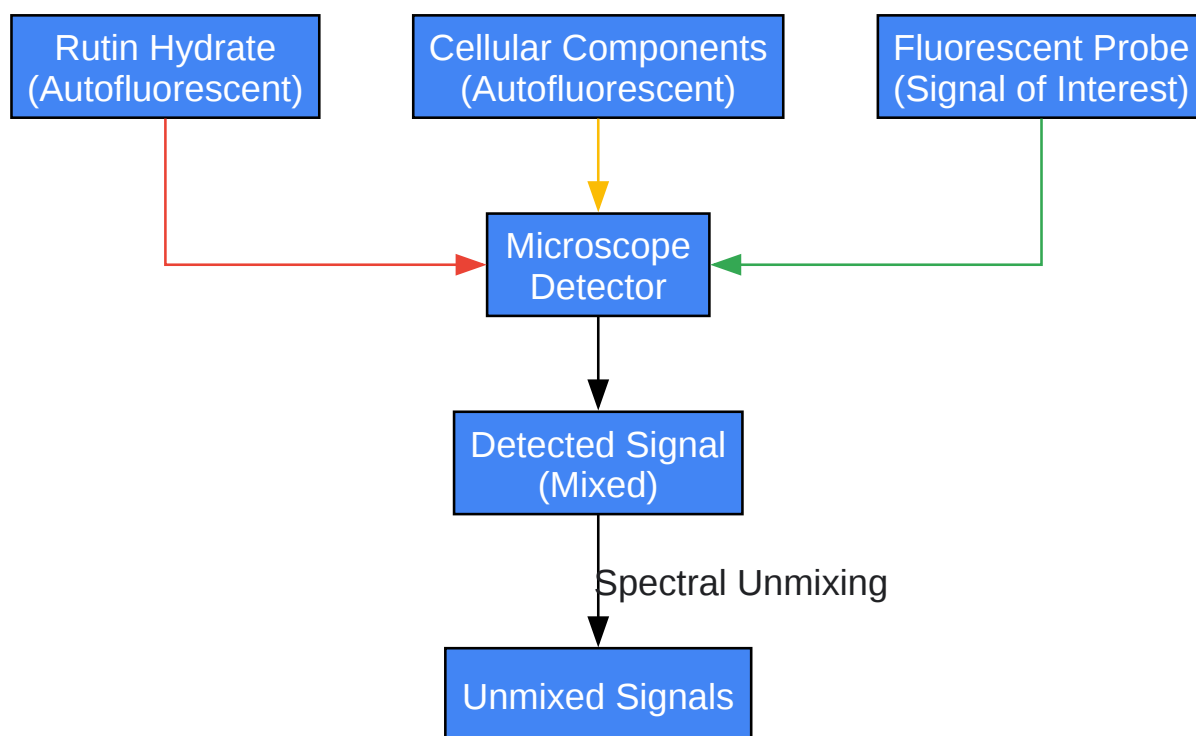

[Click to download full resolution via product page](#)

Caption: Conceptual diagram of signal detection and unmixing.

### Need Custom Synthesis?

BenchChem offers custom synthesis for rare earth carbides and specific isotopic labeling.

Email: [info@benchchem.com](mailto:info@benchchem.com) or [Request Quote Online](#).

## References

- 1. benchchem.com [benchchem.com]
- 2. Autofluorescence in Plants - PMC [pmc.ncbi.nlm.nih.gov]
- To cite this document: BenchChem. [Technical Support Center: Managing Autofluorescence of Rutin Hydrate in Imaging Studies]. BenchChem, [2025]. [Online PDF]. Available at: [https://www.benchchem.com/product/b3028452#managing-autofluorescence-of-rutin-hydrate-in-imaging-studies]

**Disclaimer & Data Validity:**

The information provided in this document is for Research Use Only (RUO) and is strictly not intended for diagnostic or therapeutic procedures. While BenchChem strives to provide accurate protocols, we make no warranties, express or implied, regarding the fitness of this product for every specific experimental setup.

**Technical Support:** The protocols provided are for reference purposes. Unsure if this reagent suits your experiment? [[Contact our Ph.D. Support Team for a compatibility check](#)]

**Need Industrial/Bulk Grade?** [Request Custom Synthesis Quote](#)

## BenchChem

Our mission is to be the trusted global source of essential and advanced chemicals, empowering scientists and researchers to drive progress in science and industry.

### Contact

Address: 3281 E Guasti Rd  
Ontario, CA 91761, United States  
Phone: (601) 213-4426  
Email: [info@benchchem.com](mailto:info@benchchem.com)