

# Application Note: Quantification of Crocin 5 in Saffron Extracts using HPLC-DAD

**Author:** BenchChem Technical Support Team. **Date:** May 2026

## Compound of Interest

|                |             |
|----------------|-------------|
| Compound Name: | Crocin 5    |
| CAS No.:       | 174916-30-4 |
| Cat. No.:      | B3028231    |

[Get Quote](#)

For Researchers, Scientists, and Drug Development Professionals

## Introduction

**Crocin 5**, also known as dicrocin, is a key bioactive carotenoid found in saffron (*Crocus sativus* L.). As a member of the crocin family, it contributes to the characteristic color and potential therapeutic properties of saffron, including antioxidant and neuroprotective effects. Accurate quantification of individual crocins like **Crocin 5** is crucial for quality control of saffron-based products and for research into their pharmacological activities. This application note provides a detailed protocol for the quantification of **Crocin 5** using High-Performance Liquid Chromatography with a Diode-Array Detector (HPLC-DAD).

## Principle

This method utilizes reversed-phase HPLC to separate **Crocin 5** from other related crocins and components present in a saffron extract. The separation is achieved based on the differential partitioning of the analytes between a nonpolar stationary phase (C18) and a polar mobile phase. The Diode-Array Detector allows for sensitive and selective detection of crocins at their maximum absorbance wavelength (around 440 nm), enabling accurate quantification.

## Experimental Protocols

### Standard and Sample Preparation

#### Standard Preparation:

- **Stock Solution (1000 µg/mL):** Accurately weigh 10 mg of **Crocin 5** reference standard and dissolve it in 10 mL of a diluent (e.g., 80% methanol in water) in a volumetric flask. Protect the solution from light.
- **Working Standard Solutions:** Prepare a series of working standard solutions by serial dilution of the stock solution with the diluent to achieve concentrations ranging from 1 µg/mL to 100 µg/mL. These will be used to construct the calibration curve.

#### Sample Preparation (Saffron Extract):

- **Extraction:** Accurately weigh 50 mg of powdered saffron stigmas and place it in a 50 mL centrifuge tube. Add 25 mL of 80% methanol.
- **Ultrasonication:** Sonicate the mixture for 30 minutes in an ultrasonic bath, ensuring the temperature does not rise significantly.
- **Centrifugation:** Centrifuge the extract at 4000 rpm for 10 minutes.
- **Filtration:** Filter the supernatant through a 0.45 µm syringe filter into an HPLC vial. Protect the vial from light and store at 4°C until analysis.

## HPLC-DAD Instrumentation and Conditions

| Parameter            | Recommended Setting   |
|----------------------|---|
| HPLC System          | A standard HPLC system with a quaternary pump, autosampler, column oven, and a Diode-Array Detector.              |
| Column               | C18 reversed-phase column (e.g., 250 mm x 4.6 mm, 5 µm particle size).  |
| Mobile Phase A       | Water with 0.1% formic acid.  |
| Mobile Phase B       | Acetonitrile with 0.1% formic acid.   |
| Gradient Elution     | 0-5 min: 10% B; 5-25 min: 10-50% B; 25-30 min: 50-90% B; 30-35 min: 90% B; 35-36 min: 90-10% B; 36-40 min: 10% B. |
| Flow Rate            | 1.0 mL/min.   |
| Injection Volume     | 10 µL.  |
| Column Temperature   | 30°C.   |
| Detection Wavelength | 440 nm.   |

## Data Analysis and Quantification

- Calibration Curve: Inject the working standard solutions and record the peak area for **Crocin 5**. Plot a calibration curve of peak area versus concentration.
- Linearity: Determine the linearity of the method by calculating the coefficient of determination ( $R^2$ ) from the calibration curve. A value of  $>0.999$  is desirable.
- Quantification: Inject the prepared saffron extract sample. Identify the **Crocin 5** peak based on its retention time compared to the standard. Calculate the concentration of **Crocin 5** in the sample using the regression equation from the calibration curve.

## Quantitative Data Summary

The following table summarizes the expected quantitative performance of this method for **Crocin 5** analysis. These values are typical and should be confirmed during in-house method

validation.

| Parameter                     | Expected Value  |
|-------------------------------|---|
| Retention Time (RT)           | Approximately 17-20 min (dependent on specific column and conditions) |
| Linearity (R <sup>2</sup> )   | > 0.999   |
| Linear Range                  | 1 - 100 µg/mL   |
| Limit of Detection (LOD)      | ~0.2 µg/mL  |
| Limit of Quantification (LOQ) | ~0.7 µg/mL  |
| Precision (%RSD)              | < 2%  |
| Accuracy (%Recovery)          | 98 - 102%   |

## Visualizations

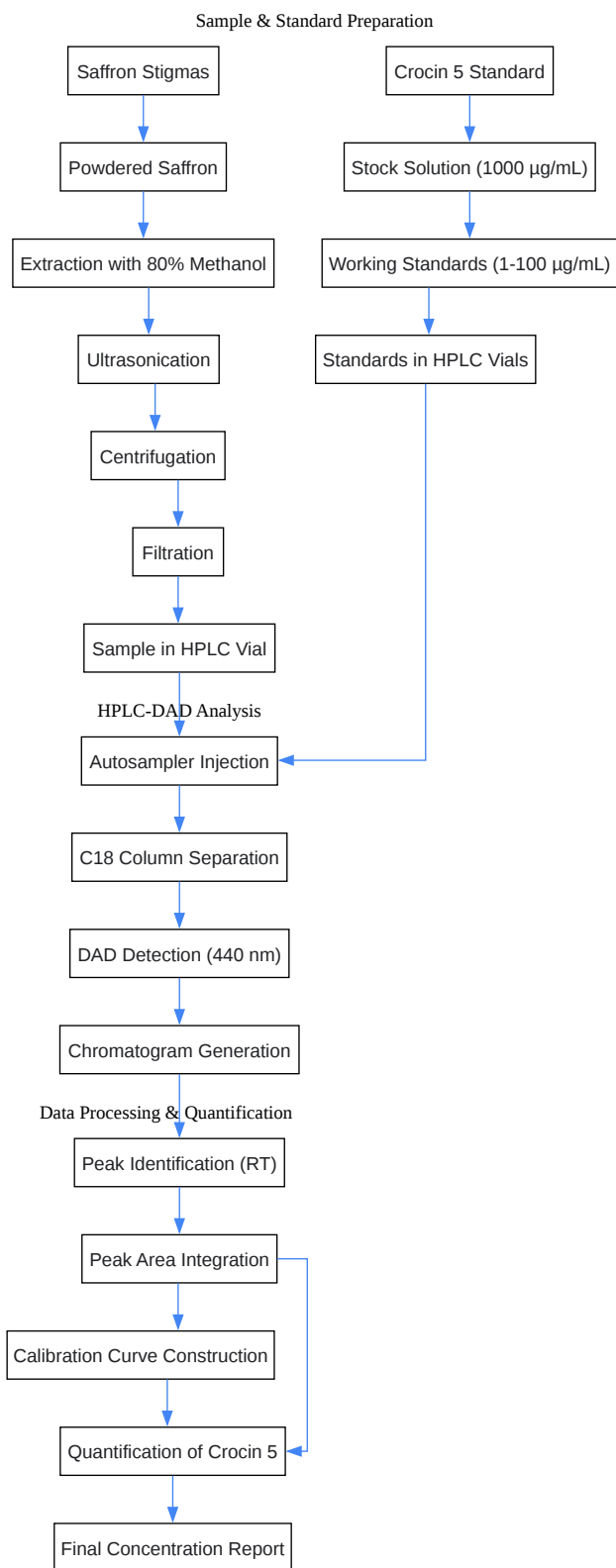

[Click to download full resolution via product page](#)

Caption: Experimental workflow for **Crocin 5** quantification.



[Click to download full resolution via product page](#)

Caption: Logical relationship of the analytical process.

## Conclusion

The described HPLC-DAD method provides a reliable and robust approach for the quantification of **Crocin 5** in saffron extracts. This application note serves as a comprehensive guide for researchers and industry professionals to ensure the quality and consistency of saffron-based products and to facilitate further research into the pharmacological benefits of its individual components. Adherence to the detailed protocols will enable accurate and reproducible results.

- To cite this document: BenchChem. [Application Note: Quantification of Crocin 5 in Saffron Extracts using HPLC-DAD]. BenchChem, [2026]. [Online PDF]. Available at: [\[https://www.benchchem.com/product/b3028231/docs#application-note-quantification-of-crocin-5-in-saffron-extracts-using-hplc-dad\]](https://www.benchchem.com/product/b3028231/docs#application-note-quantification-of-crocin-5-in-saffron-extracts-using-hplc-dad)

---

### Disclaimer & Data Validity:

The information provided in this document is for Research Use Only (RUO) and is strictly not intended for diagnostic or therapeutic procedures. While BenchChem strives to provide accurate protocols, we make no warranties, express or implied, regarding the fitness of this product for every specific experimental setup.

**Technical Support:** The protocols provided are for reference purposes. Unsure if this reagent suits your experiment?

**Need Industrial/Bulk Grade?** [Request Custom Synthesis Quote](#)

## BenchChem

Our mission is to be the trusted global source of essential and advanced chemicals, empowering scientists and researchers to drive progress in science and industry.

### Contact

Address: 3281 E Guasti Rd  
Ontario, CA 91761, United States  
Phone: (601) 213-4426  
Email: [info@benchchem.com](mailto:info@benchchem.com)

[Contact our Ph.D. Support Team for a compatibility check](#)