

Application Note: Handling and Storage of Air-Sensitive Indoline Derivatives

Author: BenchChem Technical Support Team. **Date:** April 2026

Compound of Interest

Compound Name:	4-(Indolin-5-yl)morpholine hydrochloride
CAS No.:	1646152-53-5
Cat. No.:	B3028171

[Get Quote](#)

Executive Summary

Indoline (2,3-dihydro-1H-indole) derivatives represent a critical scaffold in drug discovery, serving as precursors to indoles and acting as pharmacophores in their own right. However, their handling is complicated by a thermodynamic susceptibility to oxidative dehydrogenation. Unlike their aromatic indole counterparts, indolines possess a non-aromatic pyrrole ring that is prone to aromatization—a process driven by a gain in resonance energy (~20-25 kcal/mol).

This guide provides a rigorous, field-proven protocol for the handling and storage of these compounds. It moves beyond basic "air-free" techniques to explain the mechanistic causes of degradation and provides a self-validating system to ensure experimental integrity.

The Chemistry of Vulnerability: Why Indolines Degrade

To handle indolines effectively, one must respect the driving force behind their instability. The primary degradation pathway is Oxidative Aromatization.

The Mechanism

In the presence of atmospheric oxygen, indolines undergo dehydrogenation to form indoles. This is often catalyzed by trace metals, light, or basic conditions. The reaction proceeds via a radical mechanism where the benzylic hydrogen (C3) or the amine hydrogen (N1) is abstracted, leading to a conjugated radical intermediate that rapidly collapses to the aromatic indole.

Key Insight: The transformation is often autocatalytic. Oxidation byproducts (peroxides) can accelerate further degradation. Consequently, "slightly yellow" indoline is not just impure; it is chemically compromised and active.

Visualization of the Oxidation Pathway

The following diagram illustrates the stepwise degradation from stable indoline to the aromatic indole impurity.

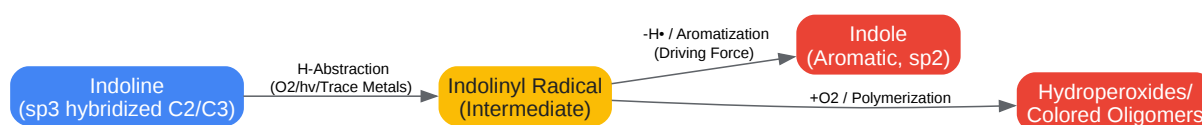

[Click to download full resolution via product page](#)

Figure 1: Mechanistic pathway of indoline oxidative dehydrogenation. The transition to the aromatic indole is thermodynamically favorable.

Material Characterization: The Self-Validating System

Before commencing any synthesis or biological assay, the integrity of the indoline material must be validated. Relying solely on bottle labels is a critical failure point.

Visual Inspection

- Pure Indoline: Typically colorless to pale yellow oils or white solids.

- Compromised: Dark yellow, brown, or reddish coloration indicates oxidation (formation of quinoidal species or oligomers).

Analytical Checkpoints (The "Go/No-Go" Decision)

Use the following table to validate purity. If the material fails these checks, proceed to Section 6 (Purification).

Technique	Observation for PURE Indoline	Observation for DEGRADED (Indole)
¹ H NMR	C2/C3 Protons: Distinct triplets/multiplets at 3.0–4.0 ppm (sp ³).	C2/C3 Protons: Disappear. Replaced by aromatic doublets at 6.5–7.5 ppm.
TLC	Rf Value: Lower Rf (more polar due to basic amine).	Rf Value: Higher Rf (less polar, aromatic system).
TLC Stain	Vanillin/P-Anisaldehyde: Often stains distinct blue/purple.	Vanillin: Stains pink/red or orange.

Handling Protocols

Solid State Handling

While solid indolines are kinetically more stable than solutions, surface oxidation occurs rapidly.

- Weighing: For high-precision assays, weigh inside a glovebox or use a Schlenk weighing bottle.
- Brief Exposure: If weighing in air is unavoidable, flush the headspace of the storage vial with Argon immediately after removing the aliquot.

Solution State Handling (Critical)

Indolines in solution are hyper-sensitive. Dissolved oxygen acts as a continuous oxidant.

Protocol: Freeze-Pump-Thaw Degassing Do not rely on simple sparging (bubbling gas) for critical stock solutions. Use the Freeze-Pump-Thaw (FPT) cycle.

- Freeze: Place the Schlenk flask containing the indoline solution into liquid nitrogen until solid.
- Pump: Open the flask to high vacuum (0.1–0.01 mmHg) for 5–10 minutes to remove headspace gas.
- Thaw: Close the flask, remove from liquid nitrogen, and thaw in a warm water bath. Gas bubbles will evolve.
- Repeat: Perform 3 cycles total.
- Backfill: Backfill with high-purity Argon (heavier than air, providing a better blanket than Nitrogen).

Workflow Visualization: The Inert Transfer

The following diagram details the correct setup for transferring indoline solutions without air exposure.

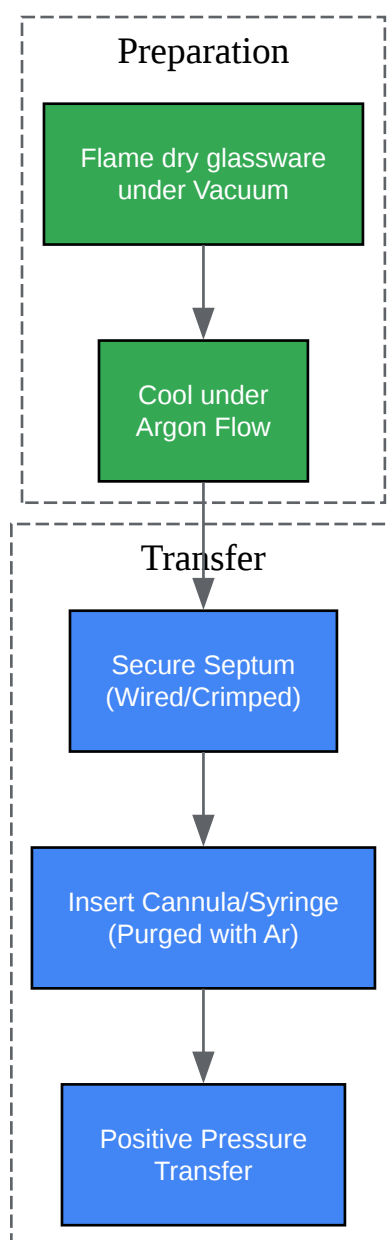

[Click to download full resolution via product page](#)

Figure 2: Inert atmosphere transfer workflow. Maintaining positive Argon pressure is critical to prevent oxygen back-diffusion.

Storage Architecture

Proper storage extends shelf-life from days to months.

Parameter	Recommendation	Rationale
Atmosphere	Argon (preferred over N2)	Argon is denser than air, forming a stable "blanket" over the solid/liquid.
Temperature	-20°C or -80°C	Arrhenius equation dictates that lower T slows oxidation kinetics significantly.
Container	Amber Vials with Teflon-lined caps	Blocks UV light (photo-oxidation trigger); Teflon prevents leaching/oxygen permeation.
Solvent	Store as SOLID	Never store long-term in chlorinated solvents (CHCl ₃ , DCM) as they can form radicals that promote oxidation.

Rescue Operations: Purification of Oxidized Material

If your "Self-Validating" check (Section 3) reveals oxidation (>5% Indole), purification is required.

Method: Acid-Base Extraction (The "Chemical Filter") Indoline is a secondary amine (basic). Indole is a very weak base (essentially neutral in dilute acid). We exploit this pKa difference.

- Dissolve: Dissolve the crude mixture in Ethyl Acetate or Ether.
- Extract: Wash with 1M HCl.
 - Result: Indoline protonates and moves to the Aqueous Layer. Indole remains in the Organic Layer.
- Wash: Wash the aqueous layer 2x with fresh organic solvent (removes trace indole).

- Basify: Slowly add 2M NaOH to the aqueous layer until pH > 10 (Indoline precipitates/oils out).
- Recover: Extract the now-basic aqueous layer with Ethyl Acetate. Dry over Na₂SO₄ and concentrate.
 - Outcome: High-purity Indoline, free of aromatic contaminants.

References

- Aerobic Oxidation Approaches to Indole-3-carboxylates. *Organic Letters*, 2019. [Link](#)
- Handling Air-Sensitive Reagents (Technical Bulletin AL-134). Sigma-Aldrich/Merck. [Link](#)
- Atmospheric oxidation mechanism and kinetics of indole. *Atmospheric Chemistry and Physics*, 2022.[1] [Link](#)
- An Illustrated Guide to Schlenk Line Techniques. *The Schlenk Line Survival Guide*, 2023.[2] [3] [Link](#)
- Metabolic Stability of Indoline Compounds. *BenchChem Application Data*, 2025. [Link](#)

Need Custom Synthesis?

BenchChem offers custom synthesis for rare earth carbides and specific isotopic labeling.

Email: info@benchchem.com or [Request Quote Online](#).

Sources

- 1. acp.copernicus.org [acp.copernicus.org]
- 2. schlenklinesurvivalguide.com [schlenklinesurvivalguide.com]
- 3. pubs.acs.org [pubs.acs.org]
- To cite this document: BenchChem. [Application Note: Handling and Storage of Air-Sensitive Indoline Derivatives]. BenchChem, [2026]. [Online PDF]. Available at: [<https://www.benchchem.com/product/b3028171/docs#application-note-handling-and-storage-of-air-sensitive-indoline-derivatives>]

Disclaimer & Data Validity:

The information provided in this document is for Research Use Only (RUO) and is strictly not intended for diagnostic or therapeutic procedures. While BenchChem strives to provide accurate protocols, we make no warranties, express or implied, regarding the fitness of this product for every specific experimental setup.

Technical Support: The protocols provided are for reference purposes. Unsure if this reagent suits your experiment?

Need Industrial/Bulk Grade? [Request Custom Synthesis Quote](#)

BenchChem

Our mission is to be the trusted global source of essential and advanced chemicals, empowering scientists and researchers to drive progress in science and industry.

Contact

Address: 3281 E Guasti Rd

Ontario, CA 91761, United States

Phone: (601) 213-4426

Email: info@benchchem.com

[Contact our Ph.D. Support Team for a compatibility check](#)