

# An In-depth Technical Guide to 4CzTPN: Properties, Synthesis, and Applications

**Author:** BenchChem Technical Support Team. **Date:** May 2026

## Compound of Interest

Compound Name:	4CzTPN
CAS No.:	1416881-53-2
Cat. No.:	B3027859

[Get Quote](#)

For Researchers, Scientists, and Drug Development Professionals

This technical guide provides a comprehensive overview of 2,3,5,6-tetrakis(carbazol-9-yl)-1,4-dicyanobenzene, commonly known as **4CzTPN**. It includes its chemical identifiers, material safety data, detailed experimental protocols for its synthesis and purification, and its applications in advanced materials science, particularly in the field of optoelectronics.

## Core Material Properties and Safety Data

**4CzTPN** is a prominent organic compound utilized primarily for its thermally activated delayed fluorescence (TADF) properties. Its unique molecular structure, featuring four carbazole donor units attached to a dicyanobenzene acceptor core, facilitates efficient reverse intersystem crossing (RISC), making it a highly effective emitter in third-generation organic light-emitting diodes (OLEDs).

Table 1: Chemical and Physical Properties of **4CzTPN**

Property	Value
CAS Number	1416881-53-2[1]
Molecular Formula	C <sub>56</sub> H <sub>32</sub> N <sub>6</sub>
Molecular Weight	788.89 g/mol
Appearance	Orange powder/crystals[1]
Melting Point	> 360 °C (lit.)[1]
Solubility	Soluble in common organic solvents like toluene.
Absorption (in toluene)	$\lambda_{\max}$ 328, 344, 485 nm[1]
Fluorescence (in toluene)	$\lambda_{\text{em}}$ 538 nm[1]
Storage Temperature	2-8°C under inert gas (Nitrogen or Argon)[1]

Table 2: Material Safety Data for 4CzTPN

Hazard Category	GHS Classification	Precautionary Statements
Skin Corrosion/Irritation	Warning: Causes skin irritation (H315)	P264, P280, P302+P352, P332+P313, P362
Serious Eye Damage/Irritation	Warning: Causes serious eye irritation (H319)	P280, P305+P351+P338, P337+P313
Specific Target Organ Toxicity (Single Exposure)	Warning: May cause respiratory irritation (H335)	P261, P271, P304+P340, P312, P403+P233, P405, P501

This data is based on the GHS classification for the closely related isomer 4CzIPN and should be used as a guideline. Always refer to the specific Safety Data Sheet (SDS) provided by the supplier.

## Experimental Protocols

## Synthesis of 4CzTPN

While a specific, detailed protocol for the synthesis of **4CzTPN** is not readily available in peer-reviewed literature, a general and widely adopted method for the synthesis of its isomer, 4CzIPN (1,2,3,5-tetrakis(carbazol-9-yl)-4,6-dicyanobenzene), can be adapted. The synthesis typically involves a nucleophilic aromatic substitution reaction between a tetra-halogenated benzene derivative and carbazole in the presence of a base.

### Materials:

- 1,2,4,5-Tetrabromobenzene (or a suitable tetra-halogenated precursor for the 1,4-dicyanobenzene core)
- Carbazole
- Potassium carbonate ( $K_2CO_3$ ) or another suitable base
- Copper(I) iodide (CuI) or another suitable catalyst
- 1,3-Dimethyl-3,4,5,6-tetrahydro-2(1H)-pyrimidinone (DMPU) or another high-boiling point polar aprotic solvent
- Toluene
- Methanol
- Deionized water

### Procedure:

- To a dried reaction flask under an inert atmosphere (e.g., argon or nitrogen), add 1,2,4,5-tetrabromobenzene (1 equivalent), carbazole (4.4 equivalents), potassium carbonate (8 equivalents), and a catalytic amount of copper(I) iodide.
- Add DMPU as the solvent and heat the reaction mixture to reflux (typically around 180-200 °C) with vigorous stirring.

- Monitor the reaction progress using thin-layer chromatography (TLC). The reaction is typically complete within 24-48 hours.
- After the reaction is complete, cool the mixture to room temperature.
- Pour the reaction mixture into a large volume of methanol to precipitate the crude product.
- Filter the precipitate and wash it sequentially with deionized water, methanol, and toluene to remove unreacted starting materials and inorganic salts.
- The resulting solid is the crude **4CzTPN**, which will require further purification.

## Purification by Sublimation

For high-purity **4CzTPN** suitable for electronic device fabrication, purification by vacuum train sublimation is the standard method.<sup>[2][3][4][5]</sup> This technique separates volatile solids based on their different sublimation and deposition temperatures under high vacuum.

### Equipment:

- Multi-zone tube furnace
- Quartz or glass sublimation tube
- High-vacuum pump capable of reaching  $< 10^{-5}$  Torr
- Temperature controllers

### Procedure:

- Place the crude **4CzTPN** powder in the source zone of the sublimation tube.
- Assemble the sublimation apparatus and evacuate the system to a high vacuum.
- Slowly heat the source zone to the sublimation temperature of **4CzTPN** (typically in the range of 300-350 °C).
- Establish a temperature gradient along the tube, with progressively cooler zones away from the source.

- **4CzTPN** will sublime and travel down the tube, depositing as a pure crystalline solid in a zone with a temperature below its sublimation point but above the condensation temperature of more volatile impurities.
- Less volatile impurities will remain in the source zone.
- After the sublimation is complete, cool the system to room temperature under vacuum.
- Carefully collect the purified **4CzTPN** from the deposition zone. The purity is often >99.9%.

[5]

## Applications in Thermally Activated Delayed Fluorescence (TADF) OLEDs

**4CzTPN** is a key material in the fabrication of highly efficient OLEDs that utilize the TADF mechanism to convert non-emissive triplet excitons into emissive singlet excitons, thus achieving theoretical internal quantum efficiencies of up to 100%.

### Fabrication of a **4CzTPN**-based TADF OLED

The following describes a typical procedure for the fabrication of a multilayer OLED device using **4CzTPN** as the emissive dopant.

Device Structure: ITO / Hole Injection Layer (HIL) / Hole Transport Layer (HTL) / Emissive Layer (EML: host doped with **4CzTPN**) / Electron Transport Layer (ETL) / Electron Injection Layer (EIL) / Cathode (e.g., Al).

Materials:

- Indium tin oxide (ITO)-coated glass substrates
- HIL material (e.g., MoO<sub>3</sub>)
- HTL material (e.g., TAPC)
- Host material for the EML (e.g., CBP, mCP)
- **4CzTPN** (dopant)

- ETL material (e.g., TPBi)
- EIL material (e.g., LiF)
- Aluminum (for cathode)

#### Procedure:

- **Substrate Cleaning:** Thoroughly clean the ITO-coated glass substrates by sequential ultrasonication in detergent, deionized water, acetone, and isopropanol. Dry the substrates in an oven and treat with UV-ozone immediately before use to improve the work function of the ITO.
- **Layer Deposition:** Deposit the organic layers and the cathode sequentially onto the ITO substrate in a high-vacuum thermal evaporation system ( $< 10^{-6}$  Torr).
  - Deposit the HIL (e.g., 10 nm of MoO<sub>3</sub>).
  - Deposit the HTL (e.g., 40 nm of TAPC).
  - Co-evaporate the host material and **4CzTPN** to form the EML (e.g., 30 nm of CBP doped with 6-10 wt% **4CzTPN**). The doping concentration is critical for device performance.
  - Deposit the ETL (e.g., 30 nm of TPBi).
  - Deposit the EIL (e.g., 1 nm of LiF).
  - Deposit the cathode (e.g., 100 nm of Al).
- **Encapsulation:** To prevent degradation from moisture and oxygen, encapsulate the device using a glass lid and UV-curable epoxy resin in an inert atmosphere (e.g., a glovebox).

## Signaling Pathways and Experimental Workflows

### Photocatalytic Cycle of 4CzTPN

**4CzTPN** and its isomers are effective metal-free photocatalysts for a variety of organic transformations.<sup>[6][7][8][9]</sup> The photocatalytic cycle is initiated by the absorption of visible light, which promotes **4CzTPN** to an excited singlet state (<sup>1</sup>**4CzTPN**). *This excited state can then*

undergo intersystem crossing to a triplet state ( $^3\mathbf{4CzTPN}$ ). Both excited states are potent redox agents. The following diagram illustrates a general photocatalytic cycle involving an oxidative quenching pathway.

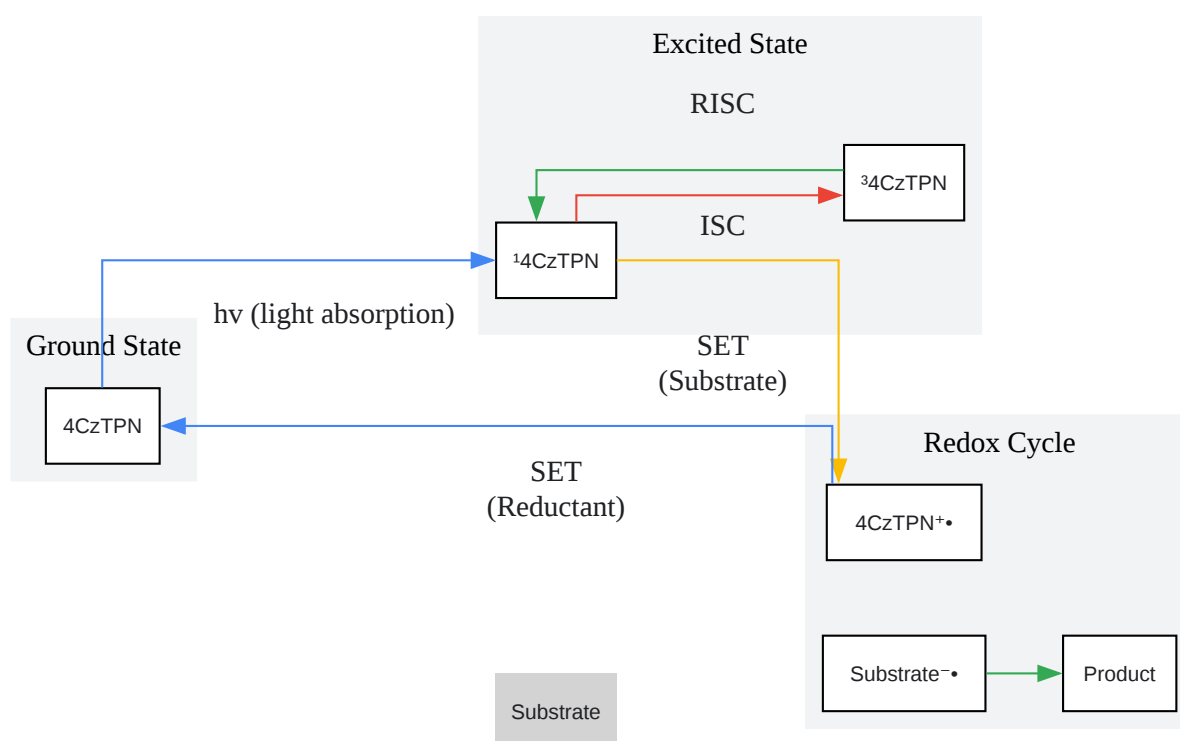

[Click to download full resolution via product page](#)

Caption: General photocatalytic cycle of  $\mathbf{4CzTPN}$  via oxidative quenching.

## TADF OLED Fabrication Workflow

The fabrication of a TADF OLED is a multi-step process requiring precise control over layer thickness and deposition conditions. The following diagram outlines the key stages in the fabrication of a **4CzTPN**-based OLED.

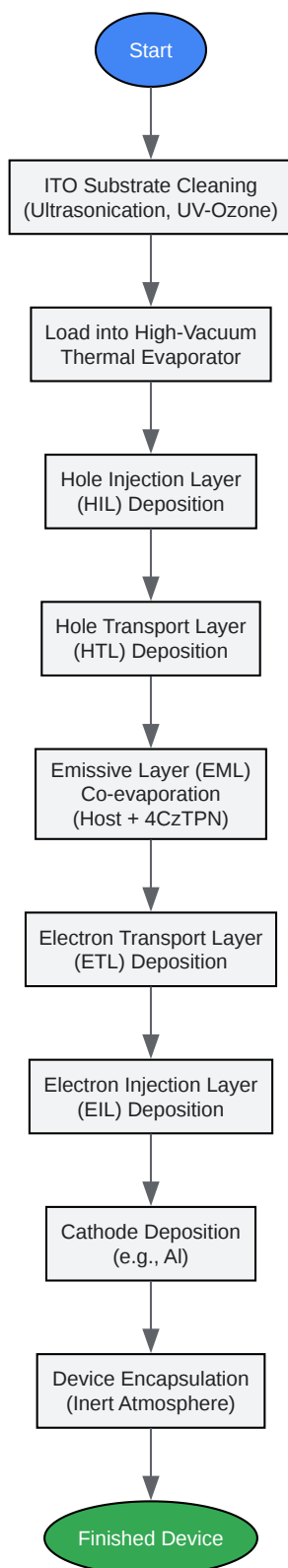

[Click to download full resolution via product page](#)

Caption: Workflow for the fabrication of a **4CzTPN**-based TADF OLED.

### Need Custom Synthesis?

BenchChem offers custom synthesis for rare earth carbides and specific isotopic labeling.

Email: [info@benchchem.com](mailto:info@benchchem.com) or [Request Quote Online](#).

## References

- [1. 2,3,5,6-tetrakis\(carbazol-9-yl\)-1,4-dicyanobenzene Five Chongqing Chemdad Co. , Ltd \[chemdad.com\]](#)
- [2. innovation.world \[innovation.world\]](#)
- [3. mbraun.com \[mbraun.com\]](#)
- [4. scribd.com \[scribd.com\]](#)
- [5. Sublimation: Isolating the Purest Chemical Compounds | Adesis, Inc. \[adesisinc.com\]](#)
- [6. Organic thermally activated delayed fluorescence \(TADF\) compounds used in photocatalysis - Chemical Society Reviews \(RSC Publishing\) DOI:10.1039/D1CS00198A \[pubs.rsc.org\]](#)
- [7. Moving Beyond Cyanoarene Thermally Activated Delayed Fluorescence Compounds as Photocatalysts: An Assessment of the Performance of a Pyrimidyl Sulfone Photocatalyst in Comparison to 4CzIPN - PMC \[pmc.ncbi.nlm.nih.gov\]](#)
- [8. Multi-Resonant Thermally Activated Delayed Fluorescent \(MR-TADF\) Compounds as Photocatalysts - PMC \[pmc.ncbi.nlm.nih.gov\]](#)
- [9. chemrxiv.org \[chemrxiv.org\]](#)
- To cite this document: BenchChem. [An In-depth Technical Guide to 4CzTPN: Properties, Synthesis, and Applications]. BenchChem, [2026]. [Online PDF]. Available at: [\[https://www.benchchem.com/product/b3027859/docs#an-in-depth-technical-guide-to-4cztpn-properties-synthesis-and-applications\]](https://www.benchchem.com/product/b3027859/docs#an-in-depth-technical-guide-to-4cztpn-properties-synthesis-and-applications)

---

### Disclaimer & Data Validity:

The information provided in this document is for Research Use Only (RUO) and is strictly not intended for diagnostic or therapeutic procedures. While BenchChem strives to provide accurate protocols, we make no warranties, express or implied, regarding the fitness of this product for every specific experimental setup.

**Technical Support:** The protocols provided are for reference purposes. Unsure if this reagent suits your experiment?

**Need Industrial/Bulk Grade?** [Request Custom Synthesis Quote](#)

## BenchChem

Our mission is to be the trusted global source of essential and advanced chemicals, empowering scientists and researchers to drive progress in science and industry.

### Contact

Address: 3281 E Guasti Rd  
Ontario, CA 91761, United States  
Phone: (601) 213-4426  
Email: [info@benchchem.com](mailto:info@benchchem.com)

[Contact our Ph.D. Support Team for a compatibility check](#)