

Bioactivity comparison of 6-Chloropyridine-2-carboximidamide vs picolinamidine

Author: BenchChem Technical Support Team. **Date:** May 2026

Compound of Interest

Compound Name: 6-Chloropyridine-2-carboximidamide

CAS No.: 1011231-34-7

Cat. No.: B3026552

[Get Quote](#)

Bioactivity Comparison: 6-Chloropyridine-2-carboximidamide vs. Picolinamidine

Executive Summary

This guide provides a technical comparison between Picolinamidine (Pyridine-2-carboximidamide), a classic pharmacophore in medicinal chemistry, and its chlorinated derivative, **6-Chloropyridine-2-carboximidamide**.

While Picolinamidine serves as a potent arginine mimetic for targeting the S1 pocket of serine proteases (e.g., Trypsin, Thrombin, Factor Xa), the 6-Chloro derivative functions primarily as a functionalized scaffold. The chlorine atom at the 6-position modulates physicochemical properties (lowering pKa, increasing lipophilicity) and, crucially, acts as a reactive "handle" for nucleophilic aromatic substitution (

), enabling the synthesis of complex antagonists (e.g., CXCR4 inhibitors).

Feature	Picolinamidine	6-Chloropyridine-2-carboximidamide
Primary Role	S1 Pocket Anchor (Serine Protease Inhibitor)	Synthetic Intermediate / Modulated Fragment
Key Interaction	Salt bridge with Asp189 (Trypsin-like enzymes)	Weakened ionic bond; Hydrophobic fill
Basicity (pKa)	High (~11.0 - 12.0)	Lowered (~9.5 - 10.5) due to inductive effect
Reactivity	Stable aromatic ring	Reactive at C6 (susceptible)
Lipophilicity	Low (Hydrophilic)	Moderate (Improved membrane permeability)

Chemical & Physicochemical Profile

The introduction of a chlorine atom at the ortho position (relative to the ring nitrogen) fundamentally alters the electronic landscape of the pyridine ring.

Structural Comparison

- Picolinamidine:** A planar, electron-deficient heteroaromatic ring attached to a highly basic amidine group. It is isosteric with the guanidine group of arginine but with different pKa properties.
- 6-Chloropyridine-2-carboximidamide:** The 6-chloro substituent exerts an electron-withdrawing inductive effect (-I), reducing the electron density on the pyridine nitrogen and, by extension, lowering the pKa of the amidine group.

Physicochemical Data Table

Property	Picolinamidine	6-Chloropyridine-2-carboximidamide	Impact of Modification
Formula			+34.5 Da (Chlorine mass)
MW	121.14 g/mol	155.58 g/mol	Increased bulk
ClogP	~ -0.5 (Hydrophilic)	~ 0.2 (Amphiphilic)	Improved passive permeability
pKa (Amidine)	~11.5	~10.2	Reduced basicity; less ionized at pH 7.4
TPSA	~50 Å ²	~50 Å ²	Unchanged polar surface area

Mechanism of Action & Bioactivity

Picolinamidine: The Serine Protease Anchor

Picolinamidine is a "privileged structure" in drug discovery, specifically designed to target the S1 specificity pocket of trypsin-like serine proteases.

- Mechanism: The amidine group is protonated at physiological pH. It forms a bidentate salt bridge with the carboxylate side chain of Aspartate 189 (in Trypsin/Thrombin numbering) at the bottom of the S1 pocket.
- Binding Mode: The pyridine ring creates Van der Waals contacts with the walls of the S1 pocket (often residues 190, 214, and 216).
- Application: Found in early Factor Xa and Thrombin inhibitors.

6-Chloropyridine-2-carboximidamide: Modulation & Functionalization

The 6-Chloro derivative is rarely used as a standalone inhibitor due to steric clashes and reduced basicity, but it serves two critical roles in Fragment-Based Drug Discovery (FBDD):

- **Electronic Modulation:** The chlorine atom lowers the pKa. In some targets, a super-basic amidine (pKa > 11) leads to poor oral bioavailability due to permanent ionization in the gut. Lowering the pKa to ~10 helps balance potency with permeability.
- **Synthetic Handle (The "Warhead"):** The 6-position is activated for nucleophilic attack. This allows researchers to attach the amidine "head" to a larger "tail" (e.g., a piperidine or diazepane ring) to reach the S2/S3 pockets or solvent-exposed regions.
 - **Example:** In CXCR4 antagonists, the 6-chloro group is displaced by a diamine linker to create the final bioactive molecule.

Visualization: Interaction & Reactivity Logic

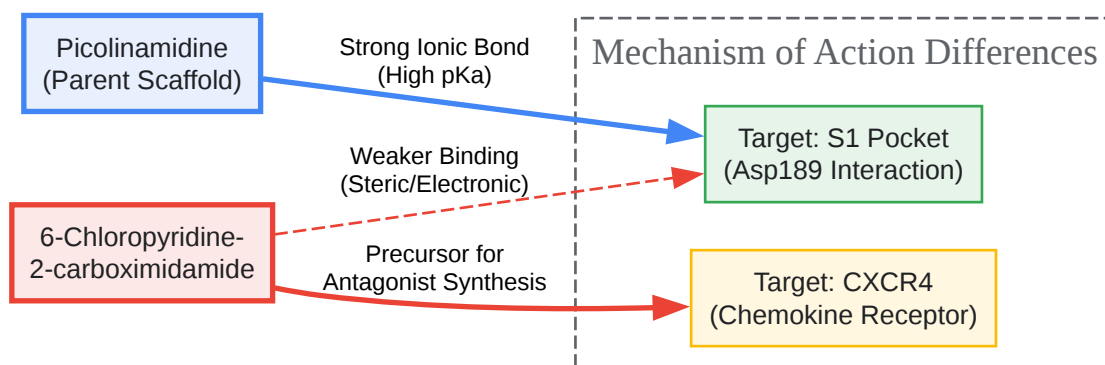

[Click to download full resolution via product page](#)

Figure 1: Functional divergence between the parent amidine (direct binder) and the chlorinated derivative (synthetic precursor/modulator).

Experimental Protocols

Synthesis of 6-Chloropyridine-2-carboximidamide

This protocol utilizes the Pinner reaction sequence, converting a nitrile to an amidine via an imidate intermediate. This is the industry-standard method for generating this intermediate.

Reagents:

- 2-Chloro-6-cyanopyridine (Starting Material)

- Ethanol (Anhydrous)
- HCl gas (or Acetyl Chloride/Ethanol)
- Ammonia (7M in Methanol)

Protocol:

- Imidate Formation: Dissolve 2-chloro-6-cyanopyridine (1 eq) in anhydrous ethanol (10-20 volumes). Cool to 0°C.
- Acidification: Bubble dry HCl gas through the solution for 15-30 minutes until saturation. Alternatively, add Acetyl Chloride dropwise (exothermic) to generate HCl in situ.
- Incubation: Stir the reaction mixture at room temperature for 18–24 hours. Monitor by TLC (disappearance of nitrile).
- Concentration: Remove the solvent in vacuo to obtain the ethyl imidate hydrochloride salt as a solid residue. Note: This intermediate is moisture-sensitive.
- Amidation: Redissolve the residue in 7M Ammonia in Methanol. Stir for 24–72 hours at room temperature.
- Purification: Concentrate the mixture. Triturate the residue with Ethyl Acetate to remove non-polar impurities. The product, **6-Chloropyridine-2-carboximidamide** hydrochloride, is collected by filtration.

Bioassay: Trypsin Inhibition (K_i Determination)

To objectively compare the binding affinity of the two compounds, a standard chromogenic substrate assay is recommended.

Reagents:

- Enzyme: Bovine Trypsin (Sigma T1426).
- Substrate: BAPNA (N α -Benzoyl-DL-arginine 4-nitroanilide hydrochloride).

- Buffer: 50 mM Tris-HCl, pH 8.0, 20 mM

.

Workflow:

- Preparation: Prepare serial dilutions of Picolinamidine and **6-Chloropyridine-2-carboximidamide** (0.1 nM to 100 μ M) in the buffer.
 - Incubation: Mix 10 μ L of inhibitor solution with 10 μ L of Trypsin (final conc. 10 nM) in a 96-well plate. Incubate for 15 mins at 25°C to allow equilibrium binding.
 - Initiation: Add 180 μ L of BAPNA substrate (final conc. 100 μ M, approx
-).
- Measurement: Monitor absorbance at 405 nm (release of p-nitroaniline) kinetically for 10 minutes.

- Analysis: Plot

vs. [I] to determine

. Calculate

using the Cheng-Prusoff equation:

.

Synthetic Utility & Pathway Visualization

The 6-Chloro derivative is most valuable when used to construct larger molecules. The diagram below illustrates its conversion into a CXCR4 antagonist scaffold.

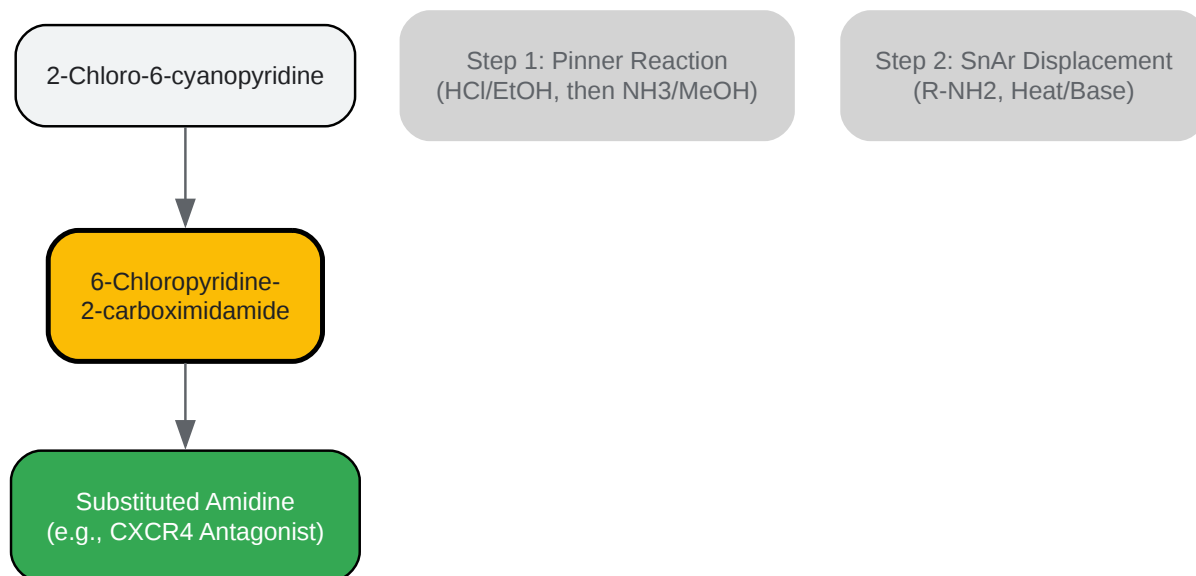

[Click to download full resolution via product page](#)

Figure 2: Synthetic route transforming the nitrile precursor into the bioactive amidine scaffold.

References

- Vertex Pharmaceuticals Inc. (2012). CXCR4 Receptor Antagonists. WO2012049277A1. [Link](#)
- GlaxoSmithKline. (2011). Receptor Antagonists. EP2927224B1. [Link](#)
- Katz, B. A., et al. (2000). Design of potent and selective inhibitors of blood coagulation factor Xa. *Journal of Medicinal Chemistry*. (Contextual reference for amidine binding modes).
- Sanderson, P. E. (2004). Small molecule inhibitors of the serine protease factor Xa. *The Journal of Medicinal Chemistry*. (Reference for Picolinamidine pharmacophore).[1][2]

Need Custom Synthesis?

BenchChem offers custom synthesis for rare earth carbides and specific isotopic labeling.

Email: info@benchchem.com or [Request Quote Online](#).

Sources

- [1. sfdchem.com \[sfdchem.com\]](#)
- [2. researchgate.net \[researchgate.net\]](#)
- To cite this document: BenchChem. [Bioactivity comparison of 6-Chloropyridine-2-carboximidamide vs picolinamidine]. BenchChem, [2026]. [Online PDF]. Available at: [<https://www.benchchem.com/product/b3026552/docs#bioactivity-comparison-of-6-chloropyridine-2-carboximidamide-vs-picolinamidine>]

Disclaimer & Data Validity:

The information provided in this document is for Research Use Only (RUO) and is strictly not intended for diagnostic or therapeutic procedures. While BenchChem strives to provide accurate protocols, we make no warranties, express or implied, regarding the fitness of this product for every specific experimental setup.

Technical Support: The protocols provided are for reference purposes. Unsure if this reagent suits your experiment?

Need Industrial/Bulk Grade? [Request Custom Synthesis Quote](#)

BenchChem

Our mission is to be the trusted global source of essential and advanced chemicals, empowering scientists and researchers to drive progress in science and industry.

Contact

Address: 3281 E Guasti Rd
Ontario, CA 91761, United States
Phone: (601) 213-4426
Email: info@benchchem.com

[Contact our Ph.D. Support Team for a compatibility check](#)