

Application Notes and Protocols for Stimulating Endothelial Cells with 20-HEPE

Author: BenchChem Technical Support Team. **Date:** April 2026

Compound of Interest

Compound Name: 20-HEPE

Cat. No.: B3026294

[Get Quote](#)

For Researchers, Scientists, and Drug Development Professionals

Introduction

20-hydroxy-5,8,11,14,17-eicosapentaenoic acid (**20-HEPE**) is a cytochrome P450 (CYP)-derived metabolite of the omega-3 fatty acid eicosapentaenoic acid (EPA). While research has extensively focused on its structural analog 20-hydroxyeicosatetraenoic acid (20-HETE), emerging interest in **20-HEPE** suggests its potential role in regulating endothelial cell function. These application notes provide a detailed protocol for stimulating endothelial cells with **20-HEPE**, based on established methodologies for the closely related compound 20-HETE. The protocols outlined below are intended to serve as a comprehensive guide for investigating the effects of **20-HEPE** on endothelial cell signaling, proliferation, migration, and angiogenesis.

Data Presentation: Quantitative Data Summary

The following tables summarize quantitative data from studies on the effects of 20-HETE on endothelial cells, which can be used as a starting point for designing experiments with **20-HEPE**.

Table 1: Effective Concentrations of 20-HETE in Endothelial Cell Assays

Cell Type	Assay	Effective Concentration	Observed Effect	Reference
Human Umbilical Vein Endothelial Cells (HUVECs)	Proliferation	0.4–2.0 μ M	Significant increase in cell proliferation after 18 hours.	[1]
Human Umbilical Vein Endothelial Cells (HUVECs)	eNOS-Hsp90 Association	10 μ M	Reduced Hsp90 association with eNOS under basal and VEGF-stimulated conditions.	[2]
Human Umbilical Vein Endothelial Cells (HUVECs)	Akt and eNOS Phosphorylation	10 μ M	Transient increases in Akt phosphorylation and increased eNOS phosphorylation after 24 hours.	[2]
Bovine Aortic Endothelial Cells	Superoxide Production	10 nM	Time-dependent increase in superoxide levels.	[3]
Human Macrovascular and Microvascular Endothelial Cells	Proliferation	Not specified	~40% stimulation of proliferation.	[4]

Table 2: Summary of 20-HETE's Pro-Angiogenic Effects

Model System	Parameter Measured	Key Findings	Reference
Human Endothelial Progenitor Cells (EPCs)	Adhesion	40 ± 5.6% increase in adhesion to fibronectin and 67 ± 10% to endothelial cell monolayer.	
In Vivo Matrigel Plug Angiogenesis Assay	Angiogenesis	3.6 ± 0.2-fold increase in angiogenesis mediated by EPCs.	
Mouse Hindlimb Ischemia Model	20-HETE Production	Markedly increased in ischemic muscles (91 ± 11 vs. 8 ± 2 pg/mg in controls).	
Human Macrovascular and Microvascular Endothelial Cells	VEGF Expression and Release	Increased as early as 4 hours after 20-HETE agonist addition.	

Experimental Protocols

Protocol 1: Preparation of 20-HEPE Stock Solution

This protocol describes the preparation of a stock solution of **20-HEPE** for use in cell culture experiments.

Materials:

- **20-HEPE**
- Ethanol (200 proof, sterile)
- Sterile microcentrifuge tubes
- 0.22 µm syringe filter

Procedure:

- Dissolving **20-HEPE**: Prepare a 1-10 mM stock solution by dissolving the appropriate amount of **20-HEPE** powder in 200 proof ethanol. Vortex thoroughly to ensure complete dissolution. Gentle warming in a 37°C water bath can aid this process.
- Sterilization: Filter-sterilize the stock solution through a 0.22 µm syringe filter into a sterile microcentrifuge tube.
- Storage: Store the stock solution at -20°C or -80°C in small aliquots to avoid repeated freeze-thaw cycles.

Note: The final concentration of the solvent (e.g., ethanol) in the cell culture medium should be kept low (ideally $\leq 0.1\%$) to avoid solvent-induced cytotoxicity. A vehicle control containing the same final concentration of the solvent should be included in all experiments.

Protocol 2: Endothelial Cell Culture and Stimulation

This protocol outlines the general procedure for culturing and stimulating endothelial cells with **20-HEPE**.

Materials:

- Primary endothelial cells (e.g., HUVECs, Bovine Aortic Endothelial Cells) or endothelial cell lines
- Complete endothelial cell growth medium
- Serum-free or low-serum medium
- **20-HEPE** stock solution
- Vehicle control (e.g., ethanol)
- Tissue culture-treated plates or flasks

Procedure:

- Cell Seeding: Seed endothelial cells at the desired density in tissue culture-treated plates or flasks. Allow the cells to adhere and reach the desired confluency (typically 70-80%) in

complete growth medium.

- Serum Starvation (Optional): To reduce basal signaling, replace the complete medium with serum-free or low-serum medium for 2-24 hours prior to stimulation.
- Cell Treatment: Prepare the desired final concentrations of **20-HEPE** by diluting the stock solution in serum-free or low-serum medium. Remove the starvation medium and add the **20-HEPE**-containing medium to the cells. Include a vehicle control group.
- Incubation: Incubate the cells for the desired period (e.g., minutes for signaling studies, hours to days for proliferation or migration assays).
- Downstream Analysis: Following incubation, cells can be harvested for various downstream analyses as described in the subsequent protocols.

Protocol 3: Western Blot Analysis for Signaling Pathway Activation

This protocol is for assessing the activation of signaling pathways (e.g., MAPK, Akt) via phosphorylation.

Materials:

- Treated endothelial cells from Protocol 2
- Ice-cold Phosphate-Buffered Saline (PBS)
- Cell lysis buffer (e.g., RIPA buffer) with protease and phosphatase inhibitors
- BCA Protein Assay Kit
- SDS-PAGE gels, running and transfer buffers
- PVDF or nitrocellulose membranes
- Blocking buffer (e.g., 5% BSA or non-fat milk in TBST)
- Primary antibodies (e.g., phospho-ERK1/2, total-ERK1/2, phospho-Akt, total-Akt)

- HRP-conjugated secondary antibodies
- Chemiluminescent substrate

Procedure:

- Cell Lysis: After treatment, wash cells with ice-cold PBS and lyse with cell lysis buffer.
- Protein Quantification: Determine the protein concentration of the lysates using a BCA assay.
- SDS-PAGE and Western Blotting: Separate equal amounts of protein by SDS-PAGE and transfer to a membrane.
- Immunoblotting: Block the membrane and incubate with primary antibodies overnight at 4°C. Wash and incubate with HRP-conjugated secondary antibodies.
- Detection: Detect the signal using a chemiluminescent substrate and an imaging system.

Protocol 4: Endothelial Cell Proliferation Assay

This protocol measures the effect of **20-HEPE** on endothelial cell proliferation.

Materials:

- Endothelial cells
- 96-well tissue culture plates
- Complete and low-serum medium
- **20-HEPE** stock solution
- Cell proliferation assay kit (e.g., MTT, BrdU, or cell counting kit)

Procedure:

- Cell Seeding: Seed endothelial cells in a 96-well plate at a low density (e.g., 2,000-5,000 cells/well).

- Treatment: After cell attachment, replace the medium with low-serum medium containing various concentrations of **20-HEPE** or a vehicle control.
- Incubation: Incubate the plate for 24-72 hours.
- Proliferation Measurement: Measure cell proliferation according to the manufacturer's instructions for the chosen assay kit.

Protocol 5: Endothelial Cell Migration Assay (Wound Healing Assay)

This protocol assesses the effect of **20-HEPE** on endothelial cell migration.

Materials:

- Endothelial cells
- 6-well or 12-well tissue culture plates
- P200 pipette tip or cell scraper
- Low-serum medium
- **20-HEPE** stock solution

Procedure:

- Create Monolayer: Seed cells to create a confluent monolayer.
- Create Wound: Create a "scratch" or "wound" in the monolayer using a sterile pipette tip.
- Treatment: Wash with PBS to remove dislodged cells and replace the medium with low-serum medium containing **20-HEPE** or a vehicle control.
- Imaging: Capture images of the wound at time 0 and at subsequent time points (e.g., 6, 12, 24 hours).
- Analysis: Measure the closure of the wound over time to quantify cell migration.

Mandatory Visualization

Signaling Pathways

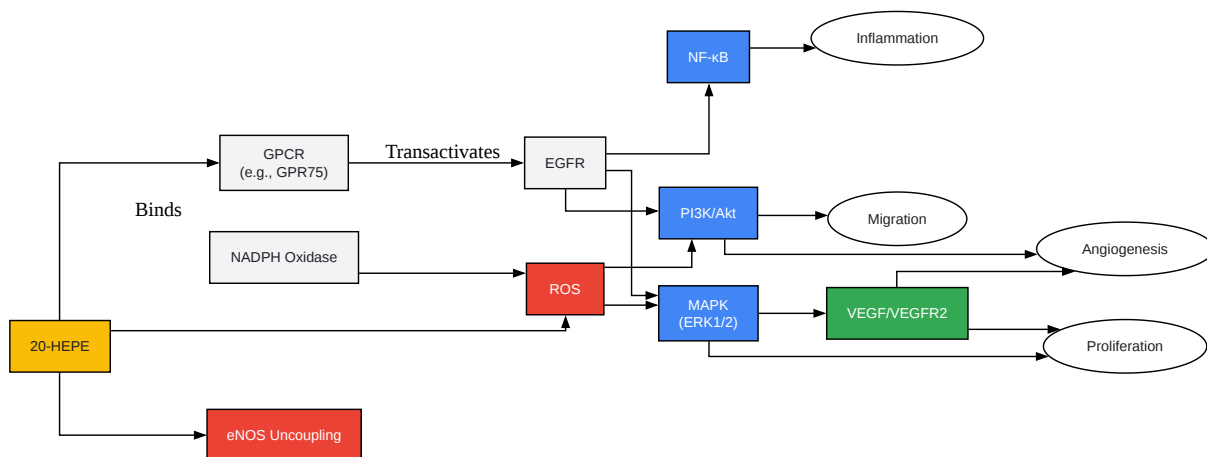

[Click to download full resolution via product page](#)

Caption: Putative signaling pathway of **20-HEPE** in endothelial cells.

Experimental Workflow

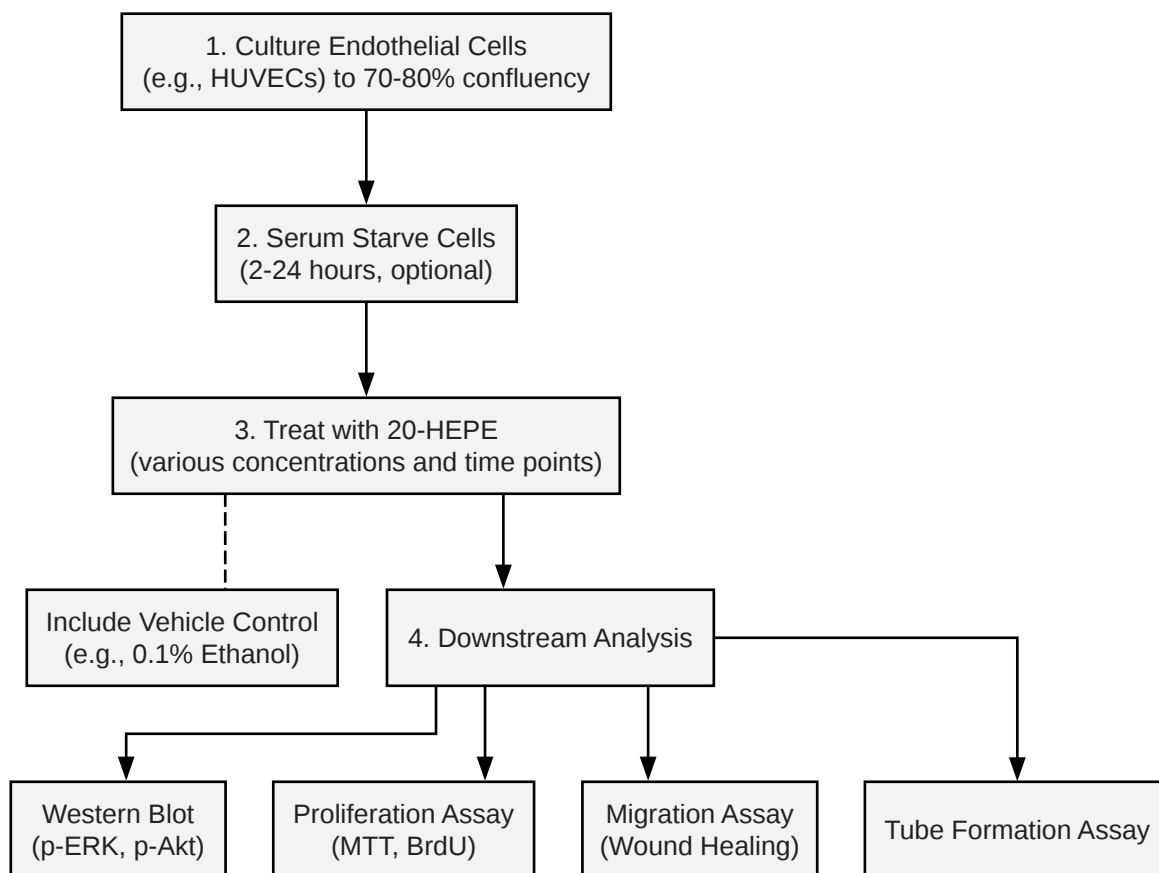

[Click to download full resolution via product page](#)

Caption: General experimental workflow for studying **20-HEPE** effects.

Need Custom Synthesis?

BenchChem offers custom synthesis for rare earth carbides and specific isotopic labeling.

Email: info@benchchem.com or [Request Quote Online](#).

References

- [1. Preparation of 20-HETE using multifunctional enzyme type 2-negative Starmerella bombicola - PMC \[pmc.ncbi.nlm.nih.gov\]](#)
- [2. Chronic AMPK activation prevents 20-HETE induced endothelial dysfunction - PMC \[pmc.ncbi.nlm.nih.gov\]](#)
- [3. researchgate.net \[researchgate.net\]](#)

- [4. Activation of vascular endothelial growth factor through reactive oxygen species mediates 20-hydroxyeicosatetraenoic acid-induced endothelial cell proliferation - PubMed \[pubmed.ncbi.nlm.nih.gov\]](#)
- To cite this document: BenchChem. [Application Notes and Protocols for Stimulating Endothelial Cells with 20-HEPE]. BenchChem, [2026]. [Online PDF]. Available at: [<https://www.benchchem.com/product/b3026294/docs#application-notes-and-protocols-for-stimulating-endothelial-cells-with-20-hepe>]

Disclaimer & Data Validity:

The information provided in this document is for Research Use Only (RUO) and is strictly not intended for diagnostic or therapeutic procedures. While BenchChem strives to provide accurate protocols, we make no warranties, express or implied, regarding the fitness of this product for every specific experimental setup.

Technical Support: The protocols provided are for reference purposes. Unsure if this reagent suits your experiment?

Need Industrial/Bulk Grade? [Request Custom Synthesis Quote](#)

BenchChem

Our mission is to be the trusted global source of essential and advanced chemicals, empowering scientists and researchers to drive progress in science and industry.

Contact

Address: 3281 E Guasti Rd
Ontario, CA 91761, United States
Phone: (601) 213-4426
Email: info@benchchem.com

[Contact our Ph.D. Support Team for a compatibility check](#)

