

A Researcher's Guide to Certified Reference Materials for Triglyceride Analysis

Author: BenchChem Technical Support Team. **Date:** April 2026

Compound of Interest

Compound Name: *1,3-Dioleoyl-2-myristoyl glycerol*

Cat. No.: *B3026147*

[Get Quote](#)

For researchers, scientists, and drug development professionals engaged in lipid analysis, the accuracy and comparability of triglyceride measurements are paramount. This guide provides an objective comparison of commercially available Certified Reference Materials (CRMs) for triglyceride analysis, supported by experimental data and detailed protocols to aid in the selection of the most appropriate reference material for your laboratory's needs.

The use of CRMs is fundamental to establishing metrological traceability, ensuring that measurement results are accurate, reliable, and comparable across different laboratories and analytical methods. This guide focuses on a comparison of prominent CRMs and the analytical methods they are used to validate.

Comparison of Certified Reference Materials for Triglyceride Analysis

The selection of a suitable CRM is a critical first step in ensuring the quality of triglyceride analysis. Here, we compare three globally recognized CRMs: NIST SRM 1951b, KRISS CRM 111-01-011, and a multi-component triglyceride mixture from Sigma-Aldrich (TraceCERT®).

Feature	NIST SRM 1951b	KRISS CRM 111-01-011	Sigma-Aldrich TraceCERT® Triglyceride Mixture
Matrix	Frozen Human Serum	Frozen Human Serum	Solid (mixture of pure triglycerides)
Analytes	Total Cholesterol, HDL-Cholesterol, LDL-Cholesterol, Triglycerides (Total Glycerides and Triglycerides only)	Triglycerides	Glycerol tridecanoate, Glycerol tridodecanoate, Glycerol trimyristate, Glycerol trioctanoate, Tripalmitin
Certified Value (Triglycerides)	Level I: 97.06 ± 0.84 mg/dL Level II: 167.6 ± 2.1 mg/dL[1]	1.825 ± 0.072 mmol/kg[2][3]	Not applicable (mixture of individual compounds with specified masses)
Certification Method	Isotope Dilution/Gas Chromatography/Mass Spectrometry (ID/GC/MS)[4]	Isotope Dilution-Liquid Chromatography–Tandem Mass Spectrometry (ID-LC–MS/MS)[2][3]	Produced and certified in accordance with ISO 17034 and ISO/IEC 17025
Intended Use	Evaluating accuracy of clinical procedures, validating secondary reference materials[4]	Ensuring SI-traceability in triglyceride measurements[2][3]	Calibration, method validation, and quality control, particularly for chromatographic methods

Performance of Common Triglyceride Analysis Methods

The performance of any triglyceride analysis is dependent on both the reference material used for calibration and the analytical method employed. The U.S. Centers for Disease Control and

Prevention (CDC) Lipid Standardization Program provides a framework for assessing the accuracy and precision of these methods against a reference measurement procedure.

Analytical Method	Typical Bias from Reference Method	Inter-Laboratory CV (%)	Key Considerations
Enzymatic Methods	-0.13% to -0.71% ^{[5][6]}	2.9% to 7.73%	Widely used in automated clinical analyzers. Performance can vary between reagent manufacturers.
Fluorometric Methods	-0.13% to -0.71% ^{[5][6]}	Generally higher than enzymatic methods	Less common now, largely replaced by enzymatic assays.
Gas Chromatography-Isotope Dilution Mass Spectrometry (GC-IDMS)	Reference Method (Bias ≈ 0)	< 1.5% ^[7]	Considered the "gold standard" reference method by the CDC for its high accuracy and precision. ^[8]

Experimental Protocols

Detailed and standardized experimental protocols are crucial for minimizing inter-laboratory variability and ensuring accurate results.

Enzymatic Triglyceride Assay (Generalized Protocol)

This is the most common routine method used in clinical laboratories. The principle involves the enzymatic hydrolysis of triglycerides to glycerol and free fatty acids, followed by a series of coupled enzymatic reactions that result in the formation of a colored or fluorescent product.

a. Reagent Preparation:

- Reconstitute the enzyme reagents and prepare the working reagent according to the manufacturer's instructions. This typically involves dissolving lyophilized powders in the

provided buffer.

b. Standard Curve Preparation:

- Prepare a series of triglyceride standards by diluting a stock standard solution with the assay buffer to generate a standard curve covering the expected range of triglyceride concentrations in the samples.

c. Sample Preparation:

- Serum or plasma samples can often be used directly.^[9] If necessary, dilute samples with high triglyceride concentrations with assay buffer to fall within the range of the standard curve.^[4]

d. Assay Procedure (Automated or Manual):

- Add a small volume of each standard and sample to individual wells of a microplate.
- Add the working enzyme reagent to each well.
- Incubate the plate at a specified temperature (e.g., 37°C) for a defined period (e.g., 5-10 minutes) to allow the enzymatic reactions to proceed.^[4]
- Measure the absorbance or fluorescence at the appropriate wavelength using a microplate reader.

e. Data Analysis:

- Subtract the absorbance/fluorescence of the blank from all standard and sample readings.
- Plot the corrected readings for the standards against their known concentrations to generate a standard curve.
- Determine the triglyceride concentration of the samples by interpolating their corrected readings from the standard curve.

CDC Reference Method: Gas Chromatography-Isotope Dilution Mass Spectrometry (GC-IDMS)

This is a highly accurate and precise method used by the CDC to assign reference values to serum materials.

a. Principle: GC-IDMS involves the addition of a known amount of a stable isotope-labeled internal standard of the analyte (e.g., $^{13}\text{C}_3$ -glycerol) to the sample. The sample is then processed to hydrolyze the triglycerides, releasing glycerol. The glycerol is derivatized to make it volatile, and the derivatized products are separated by gas chromatography and detected by mass spectrometry. The ratio of the signal from the natural analyte to the signal from the isotope-labeled internal standard is used to calculate the exact concentration of the analyte.[8]

b. Key Steps:

- **Sample Preparation:** A known amount of the isotopically labeled internal standard is added to a measured volume of the serum sample.
- **Hydrolysis:** The triglycerides in the sample are hydrolyzed under basic conditions to release glycerol.
- **Derivatization:** The glycerol is converted to a volatile derivative, typically by reaction with acetic anhydride and pyridine.[8]
- **Extraction:** The derivatized glycerol is extracted into an organic solvent.
- **GC-MS Analysis:** The extracted sample is injected into the GC-MS system. The gas chromatograph separates the derivatized glycerol from other components, and the mass spectrometer detects and quantifies the natural and isotope-labeled derivatives.
- **Quantification:** The concentration of triglycerides is determined by comparing the peak area ratio of the analyte to the internal standard against a calibration curve prepared with known concentrations of a primary reference material (e.g., NIST SRM 1595 Tripalmitin).

Visualizing Key Processes

To further aid in understanding the context and application of triglyceride analysis, the following diagrams illustrate a key metabolic pathway and a typical workflow for a clinical lipid panel.

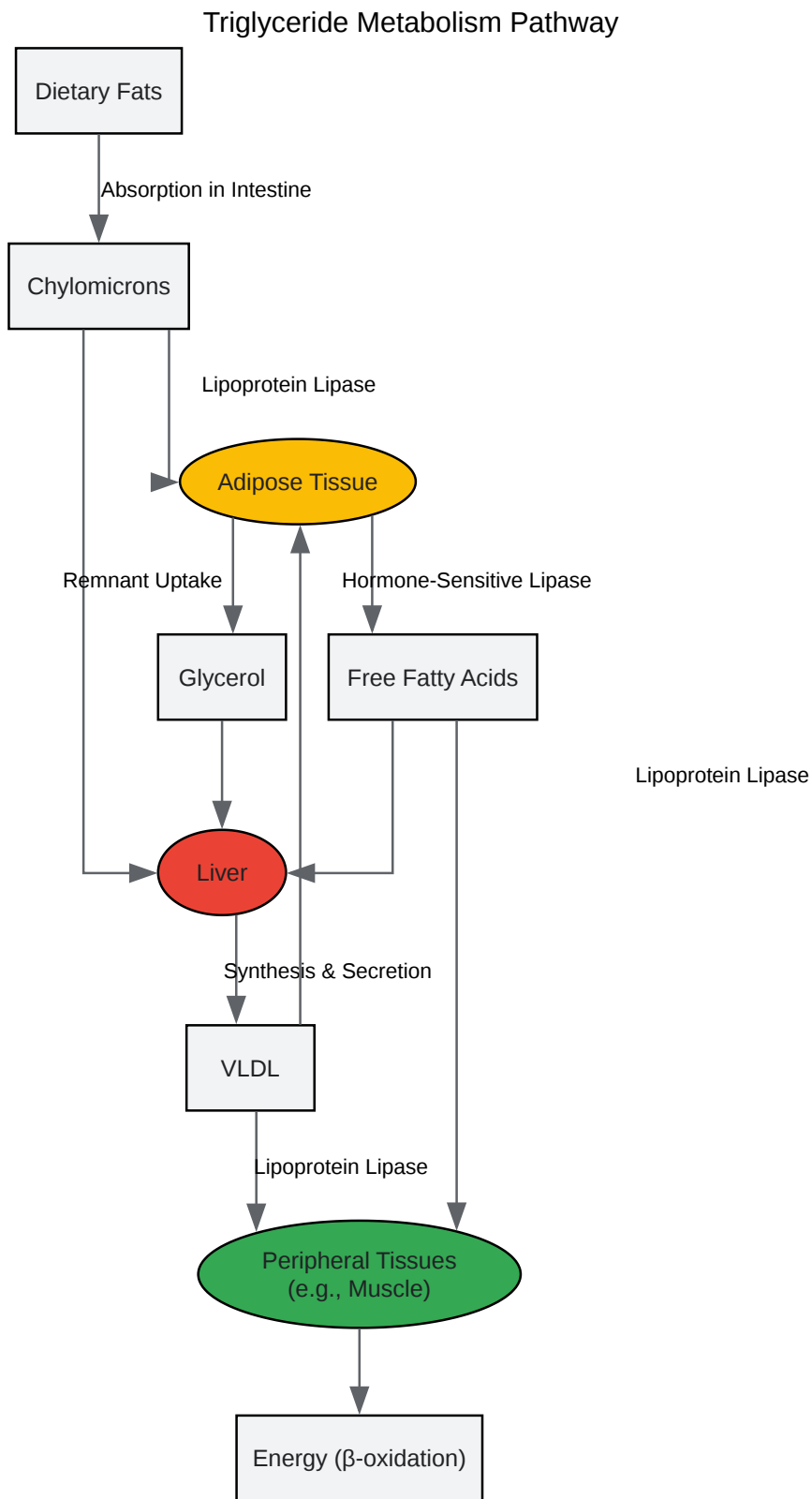

[Click to download full resolution via product page](#)

Caption: A simplified diagram of the triglyceride metabolism pathway.

Clinical Lipid Panel Analysis Workflow

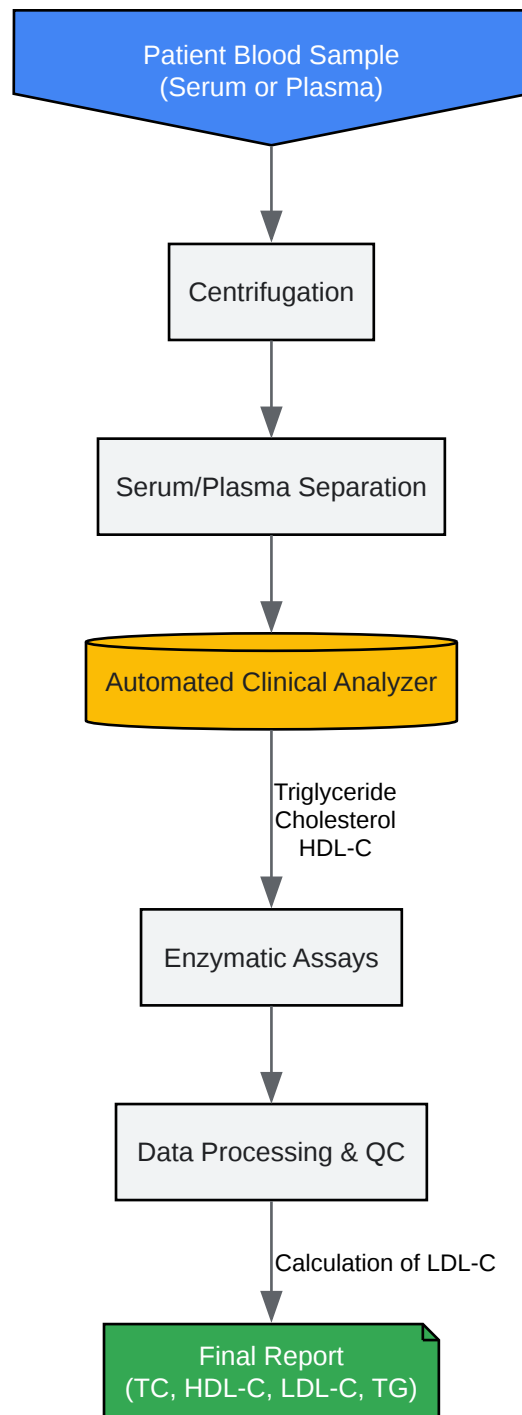

[Click to download full resolution via product page](#)

Caption: A typical workflow for a clinical lipid panel analysis.

Need Custom Synthesis?

BenchChem offers custom synthesis for rare earth carbides and specific isotopic labeling.

Email: info@benchchem.com or [Request Quote Online](#).

References

- 1. [cdc.gov](https://www.cdc.gov) [[cdc.gov](https://www.cdc.gov)]
- 2. [researchgate.net](https://www.researchgate.net) [[researchgate.net](https://www.researchgate.net)]
- 3. [researchgate.net](https://www.researchgate.net) [[researchgate.net](https://www.researchgate.net)]
- 4. search.cosmobio.co.jp [search.cosmobio.co.jp]
- 5. Comparison between the triglycerides standardization of routine methods used in Japan and the chromatographic acid reference measurement procedure used by the CDC Lipid Standardization Programme - PMC [pubmed.ncbi.nlm.nih.gov]
- 6. Comparison between the triglycerides standardization of routine methods used in Japan and the chromatographic acid reference measurement procedure used by the CDC Lipid Standardization Programme - PubMed [pubmed.ncbi.nlm.nih.gov]
- 7. How to make things work again--troubleshooting using the GC-IDMS determination of triacylglycerols as an example - PubMed [pubmed.ncbi.nlm.nih.gov]
- 8. [scispace.com](https://www.scispace.com) [[scispace.com](https://www.scispace.com)]
- 9. [sciencellonline.com](https://www.sciencellonline.com) [[sciencellonline.com](https://www.sciencellonline.com)]
- To cite this document: BenchChem. [A Researcher's Guide to Certified Reference Materials for Triglyceride Analysis]. BenchChem, [2026]. [Online PDF]. Available at: [<https://www.benchchem.com/product/b3026147/docs#a-researcher-s-guide-to-certified-reference-materials-for-triglyceride-analysis>]

Disclaimer & Data Validity:

The information provided in this document is for Research Use Only (RUO) and is strictly not intended for diagnostic or therapeutic procedures. While BenchChem strives to provide

accurate protocols, we make no warranties, express or implied, regarding the fitness of this product for every specific experimental setup.

Technical Support: The protocols provided are for reference purposes. Unsure if this reagent suits your experiment?

Need Industrial/Bulk Grade? [Request Custom Synthesis Quote](#)

BenchChem

Our mission is to be the trusted global source of essential and advanced chemicals, empowering scientists and researchers to drive progress in science and industry.

Contact

Address: 3281 E Guasti Rd

Ontario, CA 91761, United States

Phone: (601) 213-4426

Email: info@benchchem.com

[Contact our Ph.D. Support Team for a compatibility check](#)