

# Validating the Mechanism of Enhanced EGCG Delivery by Octaacetate Derivatization: A Comparative Guide

**Author:** BenchChem Technical Support Team. **Date:** December 2025

## Compound of Interest

Compound Name: EGCG Octaacetate

Cat. No.: B3025829

[Get Quote](#)

For Researchers, Scientists, and Drug Development Professionals

Epigallocatechin-3-gallate (EGCG), the most abundant catechin in green tea, has garnered significant attention for its potential therapeutic benefits, including antioxidant, anti-inflammatory, and anticancer properties.[1][2] However, its clinical translation is hampered by poor stability and low oral bioavailability.[1][3][4] To overcome these limitations, researchers have explored the derivatization of EGCG, with octaacetate derivatization (producing **EGCG octaacetate**, or pro-EGCG) emerging as a promising strategy. This guide provides a comparative analysis of EGCG and its octaacetate derivative (OA-EGCG), summarizing key performance data, detailing experimental protocols, and visualizing the underlying mechanisms and workflows.

## Enhanced Bioavailability and Cellular Uptake: A Quantitative Comparison

The primary rationale for the octaacetate derivatization of EGCG is to enhance its bioavailability. The addition of acetyl groups increases the lipophilicity of the EGCG molecule, which is thought to improve its absorption across the intestinal barrier.[5] Once absorbed, the acetyl groups are presumed to be cleaved by intracellular esterases, releasing the active EGCG.

While direct comparative pharmacokinetic data between EGCG and OA-EGCG in the same study is limited, preliminary studies on pro-EGCG in animal models provide valuable insights.

Table 1: Pharmacokinetic Parameters of Pro-EGCG (OA-EGCG) in Rats Following Oral Administration

Parameter	Value	Reference
C <sub>max</sub> (Maximum Plasma Concentration)	0.067 ± 0.04 µg/mL	[1][6]
T <sub>max</sub> (Time to Reach C <sub>max</sub> )	1.33 h	[1][6]
AUC (Area Under the Curve)	0.20 ± 0.05 h·µg/mL	[1][6]

Note: This data is for the prodrug form (pro-EGCG) and indicates extensive metabolism.[1][6] Studies on O-methylated EGCG derivatives have shown that structural modifications can significantly increase bioavailability, with the area under the curve (AUC) of an O-methylated form being approximately 8-fold higher than that of EGCG in rats.[7] This suggests that derivatization is a viable strategy for improving EGCG's pharmacokinetic profile.

## Comparative Efficacy: Anticancer Activity

The ultimate goal of enhancing EGCG delivery is to improve its therapeutic efficacy. In vitro studies have demonstrated the potent anticancer activities of EGCG.[8][9] Pro-EGCG has also been shown to suppress tumor growth in animal models.[10]

Table 2: Comparison of Anticancer Effects of EGCG and Pro-EGCG (OA-EGCG)

Compound	Cancer Model	Observed Effects	Reference
EGCG	Human Colorectal Cancer Cells (HCT-116)	Potent antiproliferative effects, induction of G1 phase cell cycle arrest and apoptosis.	[8]
EGCG	Cholangiocarcinoma Cells (HuCC-T1)	Inhibition of cell growth and viability, induction of apoptosis.	[9]
Pro-EGCG (OA-EGCG)	Endometrial Cancer (Animal Model)	Inhibition of tumor growth and angiogenesis.	[10]
Pro-EGCG (OA-EGCG)	Breast Cancer (Animal Model)	Suppression of xenograft tumor growth, inhibition of tumor angiogenesis, and reduction of VEGFA and HIF1 $\alpha$ expression via the PI3K/AKT/mTOR signaling pathway.	[10][11]

While these studies indicate the anticancer potential of both compounds, direct comparative studies using standardized metrics like IC50 values in the same cancer cell lines are needed for a definitive conclusion on their relative potency.

## Experimental Protocols

This section provides detailed methodologies for key experiments relevant to the study of EGCG and OA-EGCG.

## Synthesis of EGCG Octaacetate (Pro-EGCG)

This protocol is adapted from a published procedure.[6]

Materials:

- (-)-Epigallocatechin-3-gallate (EGCG)
- Pyridine
- Acetic anhydride
- Dichloromethane
- Hexane
- Ethyl acetate
- Round-bottom flask
- Magnetic stirrer
- Rotary evaporator
- Flash chromatography system

Procedure:

- Dissolve EGCG (e.g., 10 mg, 0.02 mmol) in pyridine (2 ml) in a round-bottom flask.
- Add acetic anhydride (0.5 ml) to the solution at room temperature.
- Stir the resulting mixture overnight at room temperature.
- Dry the reaction mixture under vacuum using a rotary evaporator.
- Dissolve the resulting crude solid in a minimal amount of dichloromethane.
- Purify the crude product by flash chromatography using a hexane-ethyl acetate solvent system (e.g., 4:1 ratio).
- Collect the fractions containing the purified **EGCG octaacetate** and evaporate the solvent to obtain the final product.

## Cellular Uptake Assay

This is a general protocol that can be adapted for comparing the cellular uptake of EGCG and OA-EGCG.<sup>[12][13][14]</sup>

Materials:

- Cancer cell line of interest (e.g., MCF-7, HCT-116)
- Cell culture medium and supplements
- EGCG and OA-EGCG
- Phosphate-buffered saline (PBS)
- Lysis buffer (e.g., RIPA buffer)
- High-performance liquid chromatography (HPLC) system or a fluorescence spectrophotometer if using fluorescently labeled compounds.
- 24-well plates

Procedure:

- Seed the cells in 24-well plates and allow them to adhere and grow to near confluence.
- Prepare stock solutions of EGCG and OA-EGCG in a suitable solvent (e.g., DMSO) and then dilute to the desired final concentrations in cell culture medium.
- Remove the culture medium from the wells and replace it with the medium containing the test compounds (EGCG or OA-EGCG) or a vehicle control.
- Incubate the cells for a predetermined time course (e.g., 1, 2, 4, 6 hours) at 37°C.
- At each time point, aspirate the medium and wash the cells three times with ice-cold PBS to remove any extracellular compound.
- Lyse the cells by adding a suitable lysis buffer to each well.

- Collect the cell lysates and analyze the intracellular concentration of EGCG and OA-EGCG using a validated analytical method such as HPLC.
- Normalize the intracellular concentration to the total protein content of each sample, determined by a protein assay (e.g., BCA assay).

## Quantification of EGCG and OA-EGCG in Plasma

This protocol is based on a validated UPLC-Qtof-MS method.[\[1\]](#)

Materials:

- Plasma samples
- Formic acid
- Isopropanol
- Methyl-tert-butyl ether (MTBE)
- Magnesium chloride solution
- Internal standard (e.g., EGCG-octaacetate-<sup>13</sup>C<sub>8</sub>)
- UPLC-Qtof-MS system

Procedure:

- To stabilize pro-EGCG, mix 50  $\mu$ L of plasma with 6  $\mu$ L of formic acid.
- Spike the plasma aliquot with an internal standard.
- Add 300  $\mu$ L of isopropanol and 3  $\mu$ L of formic acid. Vortex for 2 minutes and sonicate for 2 minutes.
- Add 1 mL of MTBE and 150  $\mu$ L of 0.043% magnesium chloride solution. Vortex for 2 minutes and sonicate for 2 minutes.
- Centrifuge the mixture at  $2,624 \times g$  and  $4^{\circ}\text{C}$  for 10 minutes.

- Transfer the upper organic layer to a new tube and evaporate to dryness under a stream of nitrogen.
- Reconstitute the residue in a suitable solvent (e.g., methanol) and inject it into the UPLC-Qtof-MS system for analysis.

## Visualizing the Mechanisms and Workflows

The following diagrams, generated using the DOT language, illustrate the proposed mechanism of enhanced EGCG delivery, a comparative experimental workflow, and the signaling pathway affected by these compounds.

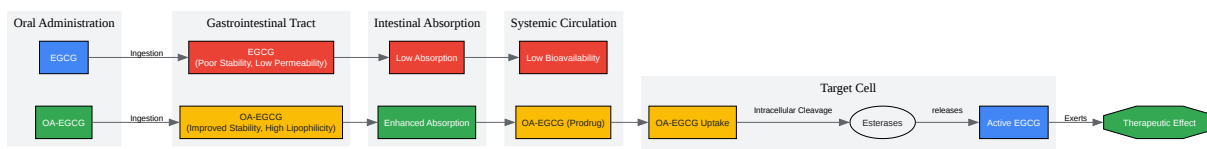

[Click to download full resolution via product page](#)

Caption: Proposed mechanism of enhanced EGCG delivery via octaacetate derivatization.

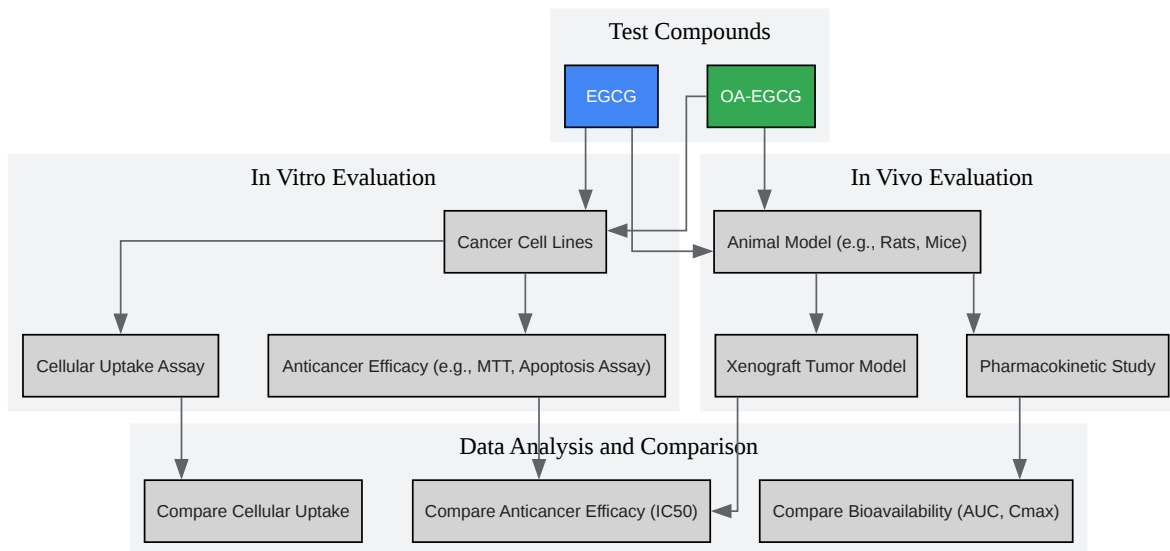

[Click to download full resolution via product page](#)

Caption: Comparative experimental workflow for evaluating EGCG and OA-EGCG.



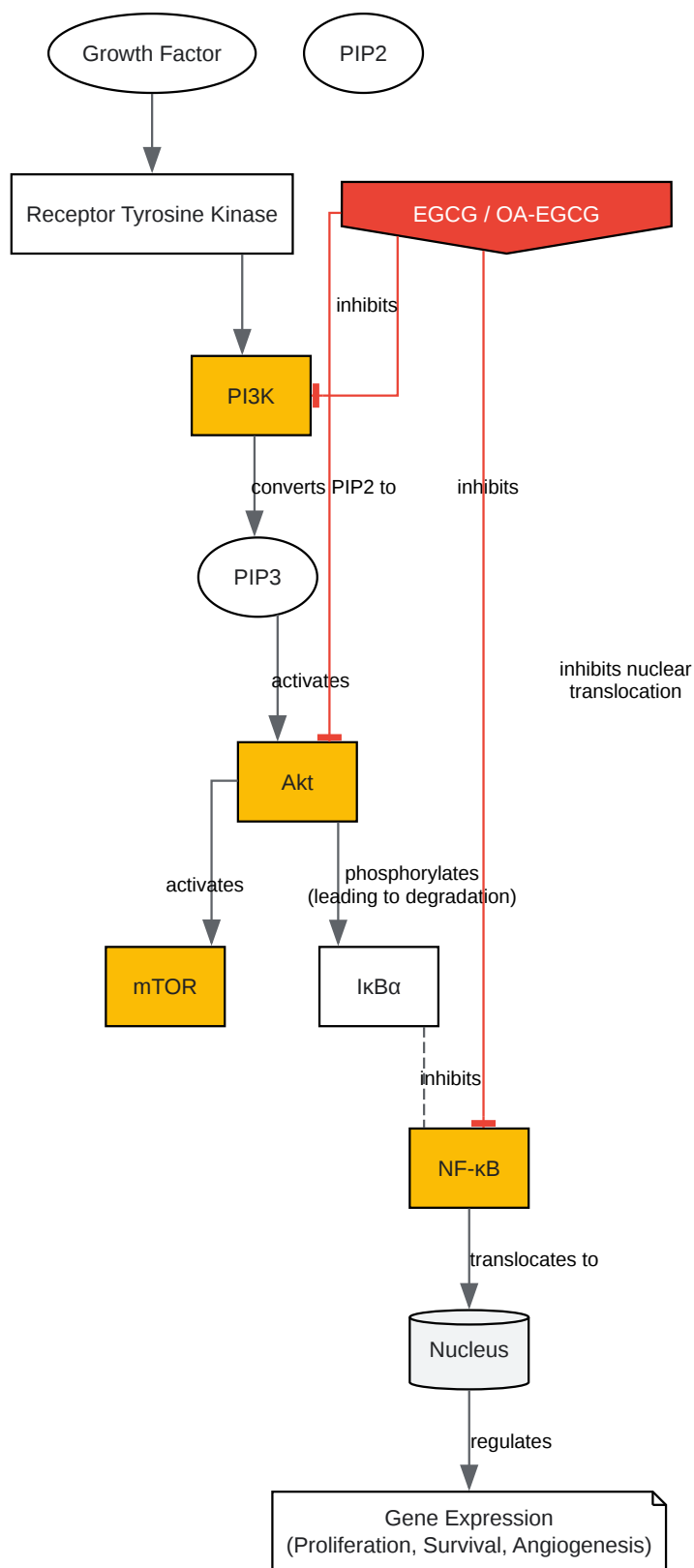

[Click to download full resolution via product page](#)

Caption: The PI3K/Akt/NF-κB signaling pathway and points of inhibition by EGCG/OA-EGCG.

### Need Custom Synthesis?

BenchChem offers custom synthesis for rare earth carbides and specific isotopic labeling.

Email: [info@benchchem.com](mailto:info@benchchem.com) or [Request Quote Online](#).

## References

- 1. Frontiers | Determination of (-)-epigallocatechin-3-gallate octaacetate and its metabolites in plasma of rats for pharmacokinetic study by ultra-performance-liquid-chromatography coupled to quadrupole-time-of-flight-mass-spectrometry [frontiersin.org]
- 2. Cellular Uptake of Epigallocatechin Gallate in Comparison to Its Major Oxidation Products and Their Antioxidant Capacity In Vitro - PMC [pmc.ncbi.nlm.nih.gov]
- 3. mdpi.com [mdpi.com]
- 4. accurateclinic.com [accurateclinic.com]
- 5. Comprehensive Review of EGCG Modification: Esterification Methods and Their Impacts on Biological Activities | MDPI [mdpi.com]
- 6. researchgate.net [researchgate.net]
- 7. Comparison of (-)-epigallocatechin-3-O-gallate (EGCG) and O-methyl EGCG bioavailability in rats - PubMed [pubmed.ncbi.nlm.nih.gov]
- 8. mdpi.com [mdpi.com]
- 9. dovepress.com [dovepress.com]
- 10. Protective Effects of Epigallocatechin Gallate (EGCG) on Endometrial, Breast, and Ovarian Cancers - PMC [pmc.ncbi.nlm.nih.gov]
- 11. mdpi.com [mdpi.com]
- 12. giffordbioscience.com [giffordbioscience.com]
- 13. Determination of Cellular Uptake and Endocytic Pathways - PMC [pmc.ncbi.nlm.nih.gov]
- 14. mm-encapsulation.com [mm-encapsulation.com]
- To cite this document: BenchChem. [Validating the Mechanism of Enhanced EGCG Delivery by Octaacetate Derivatization: A Comparative Guide]. BenchChem, [2025]. [Online PDF]. Available at: [<https://www.benchchem.com/product/b3025829#validating-the-mechanism-of-enhanced-egcg-delivery-by-octaacetate-derivatization>]

**Disclaimer & Data Validity:**

The information provided in this document is for Research Use Only (RUO) and is strictly not intended for diagnostic or therapeutic procedures. While BenchChem strives to provide accurate protocols, we make no warranties, express or implied, regarding the fitness of this product for every specific experimental setup.

**Technical Support:** The protocols provided are for reference purposes. Unsure if this reagent suits your experiment? [[Contact our Ph.D. Support Team for a compatibility check](#)]

**Need Industrial/Bulk Grade?** [Request Custom Synthesis Quote](#)

## BenchChem

Our mission is to be the trusted global source of essential and advanced chemicals, empowering scientists and researchers to drive progress in science and industry.

### Contact

Address: 3281 E Guasti Rd  
Ontario, CA 91761, United States  
Phone: (601) 213-4426  
Email: [info@benchchem.com](mailto:info@benchchem.com)