

Technical Support Center: Optimizing Lewis Acid Catalyst Ratios for Benzophenone Synthesis

Author: BenchChem Technical Support Team. **Date:** May 2026

Compound of Interest

Compound Name:	3,5-Dichloro-3',4'- dimethylbenzophenone
CAS No.:	951884-27-8
Cat. No.:	B3025062

[Get Quote](#)

Welcome to the Technical Support Center for benzophenone synthesis. This guide is designed for researchers, scientists, and drug development professionals to provide in-depth, practical solutions to common challenges encountered during the Lewis acid-catalyzed synthesis of benzophenone and its derivatives. Here, we move beyond simple protocols to explain the causality behind experimental choices, ensuring a deeper understanding and more effective troubleshooting.

Frequently Asked Questions (FAQs)

Q1: Why is a stoichiometric amount or even a slight excess of the Lewis acid catalyst, like AlCl_3 , typically required in Friedel-Crafts acylation for benzophenone synthesis?

A1: This is a critical and often misunderstood aspect of Friedel-Crafts acylation. Unlike some catalytic reactions where a small amount of catalyst is sufficient, the synthesis of benzophenone requires a stoichiometric quantity of the Lewis acid for two primary reasons.^[1]
^[2] First, the Lewis acid is needed to activate the benzoyl chloride, forming the highly

electrophilic acylium ion that is then attacked by the benzene ring.[3][4][5] Second, and crucially, the benzophenone product itself is a Lewis base due to the lone pairs on the carbonyl oxygen. It readily forms a stable complex with the Lewis acid.[1][2] This complexation effectively sequesters the catalyst, removing it from the reaction cycle.[6] Therefore, to ensure enough free catalyst is available to activate all the benzoyl chloride, at least one equivalent of the Lewis acid is necessary. A slight excess (typically 1.1 to 1.2 equivalents) is often used to drive the reaction to completion.[6]

Q2: I'm observing a low yield in my benzophenone synthesis despite using the correct stoichiometry of reactants and catalyst. What are the likely causes?

A2: Low yields in Friedel-Crafts acylation can stem from several factors. Here are the most common culprits:

- **Presence of Moisture:** Lewis acids like aluminum chloride react vigorously with water.[7] This not only deactivates the catalyst but can also lead to the hydrolysis of the benzoyl chloride starting material.[8] Ensure all glassware is rigorously dried, and that your solvents and reagents are anhydrous.[6][9]
- **Deactivated Aromatic Substrate:** If you are synthesizing a substituted benzophenone and your aromatic ring contains strongly electron-withdrawing groups (e.g., $-\text{NO}_2$, $-\text{CN}$), the ring will be deactivated towards electrophilic aromatic substitution, hindering the reaction.[6]
- **Impure Reagents:** The quality of your Lewis acid and benzoyl chloride is paramount. Old or improperly stored reagents can lead to significantly lower yields.[9]
- **Reaction Temperature:** While the reaction is often initiated at a low temperature (e.g., $0\text{ }^\circ\text{C}$) to control the initial exotherm, insufficient heating during the reaction can lead to incomplete conversion.[9][10] Conversely, excessively high temperatures can promote side reactions and charring.[9]

Q3: My reaction mixture turned dark and I've isolated a tarry, intractable material instead of my desired benzophenone. What happened?

A3: The formation of a dark, tarry substance is a common issue and usually points to side reactions or decomposition. The primary causes include:

- **Excessive Reaction Temperature:** Overheating the reaction mixture can lead to polymerization and decomposition of the starting materials and product.[9]
- **Side Reactions:** Friedel-Crafts reactions can be prone to side reactions, especially if the reaction conditions are not carefully controlled.[3] For instance, if there are any alkyl groups on your benzene ring, you might see unwanted alkylation reactions.
- **Impure Benzene:** Using benzene that is not thiophene-free can lead to side reactions and lower yields.[9]

Q4: Can I use a catalytic amount of a milder Lewis acid for benzophenone synthesis?

A4: While strong Lewis acids like AlCl_3 are typically used in stoichiometric amounts, it is possible to use catalytic amounts of milder Lewis acids, such as zinc chloride (ZnCl_2) or iron(III) chloride (FeCl_3), particularly when the aromatic ring is activated (contains electron-donating groups).[10] However, these reactions often require higher temperatures to achieve reasonable yields.[10] For unactivated substrates like benzene, using a catalytic amount of a mild Lewis acid will generally result in very low yields (below 10%).[10]

Troubleshooting Guide: A Deeper Dive

This section provides a more granular approach to diagnosing and solving specific issues you might encounter.

Problem: Low or No Product Formation

Initial Checks:

- **Reagent Purity:** Verify the purity and dryness of your benzene, benzoyl chloride, and Lewis acid. Use freshly opened or properly stored anhydrous reagents.
- **Glassware:** Ensure all glassware was scrupulously dried before use. Flame-drying under vacuum or oven-drying are recommended.
- **Inert Atmosphere:** The reaction is sensitive to atmospheric moisture. Conduct the reaction under a dry, inert atmosphere (e.g., nitrogen or argon).

Advanced Troubleshooting:

Symptom	Potential Cause	Suggested Solution
Reaction fails to initiate (no HCl evolution).	Insufficiently active catalyst or reaction temperature is too low.	Add a small crystal of iodine to activate the reaction. Ensure the initial temperature is not too low to prevent the reaction from starting.[9]
Reaction starts but stalls before completion.	Insufficient catalyst or catalyst deactivation.	Add an additional portion of the Lewis acid. This is particularly relevant if your aromatic substrate has any basic functionalities that can complex with the catalyst.[6]
Product is isolated, but the yield is consistently low.	Sub-optimal reaction conditions.	A systematic optimization of reaction parameters (temperature, reaction time, and catalyst loading) may be necessary. A design of experiments (DoE) approach can be highly effective.[10]

Problem: Formation of Byproducts

Common Byproducts and Their Causes:

Byproduct	Potential Cause	Identification	Mitigation Strategy
Benzoic Acid	Hydrolysis of benzoyl chloride.	Can be detected by IR (broad O-H stretch) and NMR spectroscopy.	Ensure strictly anhydrous conditions. [8]
Diphenylmethane	Over-reduction of benzophenone.	Can be identified by GC-MS and NMR.	This is more common in catalytic hydrogenations of benzophenone, but can occur under certain Friedel-Crafts conditions if reducing agents are inadvertently present. [11]
Poly-acylated products	The product is more reactive than the starting material.	Can be detected by chromatography (TLC, GC) and mass spectrometry.	This is less of a concern in Friedel-Crafts acylation compared to alkylation, as the acyl group deactivates the aromatic ring to further substitution. [1] [4] However, with highly activated aromatic rings, it can still occur. Using a less reactive Lewis acid or lower temperatures can help.

Experimental Protocols

General Procedure for the Synthesis of Benzophenone

Materials:

- Anhydrous Aluminum Chloride (AlCl_3)
- Anhydrous Benzene (thiophene-free)
- Benzoyl Chloride
- Anhydrous Dichloromethane (DCM) or Carbon Tetrachloride (CCl_4) (as solvent)
- Hydrochloric Acid (HCl), concentrated
- Ice

Procedure:

- Set up a three-necked round-bottom flask equipped with a mechanical stirrer, a dropping funnel, and a condenser fitted with a gas outlet to a trap for HCl gas.
- In the flask, combine anhydrous benzene and the solvent.
- Cool the flask in an ice bath to 0-5 °C.
- Slowly and carefully add anhydrous aluminum chloride to the stirred benzene solution.
- Once the AlCl_3 has been added, add benzoyl chloride dropwise from the dropping funnel over a period of 30-60 minutes, maintaining the temperature between 5-10 °C.[9]
- After the addition is complete, allow the reaction mixture to slowly warm to room temperature and then heat to a gentle reflux for 1-3 hours.[12]
- Cool the reaction mixture back down in an ice bath.
- Very slowly and cautiously quench the reaction by adding crushed ice, followed by concentrated HCl.
- Separate the organic layer. Extract the aqueous layer with the solvent.

- Combine the organic layers, wash with water, then with a dilute sodium bicarbonate solution, and finally with brine.
- Dry the organic layer over anhydrous magnesium sulfate or sodium sulfate, filter, and remove the solvent under reduced pressure.
- The crude benzophenone can be purified by recrystallization from ethanol or by vacuum distillation.[12]

Visualizing the Process

Workflow for Troubleshooting Low Yield

Caption: Troubleshooting workflow for low yield in benzophenone synthesis.

Mechanism of Lewis Acid Catalysis

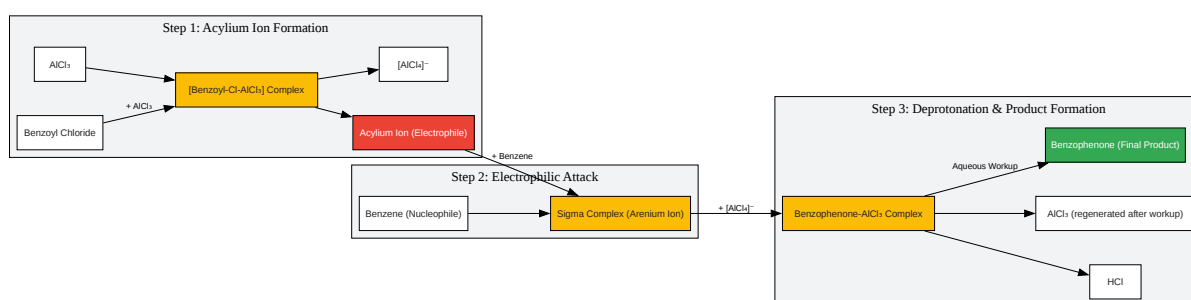

[Click to download full resolution via product page](#)

Need Custom Synthesis?

BenchChem offers custom synthesis for rare earth carbides and specific isotopic labeling.

Email: info@benchchem.com or [Request Quote Online](#).

Sources

- [1. Friedel–Crafts reaction - Wikipedia \[en.wikipedia.org\]](#)
- [2. Friedel-Crafts Acylation \[organic-chemistry.org\]](#)
- [3. SATHEE: Friedel Crafts Reaction \[sathee.iitk.ac.in\]](#)
- [4. Friedel-Crafts Acylation - Chemistry Steps \[chemistrysteps.com\]](#)
- [5. masterorganicchemistry.com \[masterorganicchemistry.com\]](#)
- [6. pdf.benchchem.com \[pdf.benchchem.com\]](#)
- [7. sciencemadness.org \[sciencemadness.org\]](#)
- [8. theses.gla.ac.uk \[theses.gla.ac.uk\]](#)
- [9. Organic Syntheses Procedure \[orgsyn.org\]](#)
- [10. researchgate.net \[researchgate.net\]](#)
- [11. pubs.acs.org \[pubs.acs.org\]](#)
- [12. sites.science.oregonstate.edu \[sites.science.oregonstate.edu\]](#)
- To cite this document: BenchChem. [Technical Support Center: Optimizing Lewis Acid Catalyst Ratios for Benzophenone Synthesis]. BenchChem, [2026]. [Online PDF]. Available at: [<https://www.benchchem.com/product/b3025062/docs#technical-support-center-optimizing-lewis-acid-catalyst-ratios-for-benzophenone-synthesis>]

Disclaimer & Data Validity:

The information provided in this document is for Research Use Only (RUO) and is strictly not intended for diagnostic or therapeutic procedures. While BenchChem strives to provide accurate protocols, we make no warranties, express or implied, regarding the fitness of this product for every specific experimental setup.

Technical Support: The protocols provided are for reference purposes. Unsure if this reagent suits your experiment?

Need Industrial/Bulk Grade? [Request Custom Synthesis Quote](#)

BenchChem

Our mission is to be the trusted global source of essential and advanced chemicals, empowering scientists and researchers to drive progress in science and industry.

Contact

Address: 3281 E Guasti Rd
Ontario, CA 91761, United States
Phone: (601) 213-4426
Email: info@benchchem.com

[Contact our Ph.D. Support Team for a compatibility check](#)