

Reproducibility of published synthesis methods for (2,5-Dimethoxybenzylidene)propanedinitrile

Author: BenchChem Technical Support Team. **Date:** April 2026

Compound of Interest

Compound Name:	(2,5-Dimethoxybenzylidene)propanedinitrile
CAS No.:	2972-75-0
Cat. No.:	B3025324

[Get Quote](#)

Reproducibility Guide: Synthesis of (2,5-Dimethoxybenzylidene)propanedinitrile Executive Summary & Technical Context

Compound: **(2,5-Dimethoxybenzylidene)propanedinitrile** CAS: 2972-75-0 Synonyms: 2-(2,5-Dimethoxybenzylidene)malononitrile; 2,5-Dimethoxybenzalmalononitrile.[1]

This guide evaluates the reproducibility of synthesis methods for **(2,5-Dimethoxybenzylidene)propanedinitrile**, a critical intermediate in the development of tyrosinase inhibitors and fused heterocyclic pharmacophores (e.g., pyranoquinolinones). The Knoevenagel condensation between 2,5-dimethoxybenzaldehyde and malononitrile is the standard route; however, reproducibility varies significantly based on catalyst choice and solvent systems.

This analysis compares two distinct methodologies:

- Method A (Classical): Base-catalyzed condensation in Ethanol (High reliability, moderate greenness).[1]
- Method B (Green Catalytic): Silicomolybdic Acid (SMA) catalyzed reaction in Ethanol:Water (High atom economy, room temperature).[1]

Chemical Profile & Validation Parameters

Use these physical constants to validate product purity immediately after synthesis.

Parameter	Specification	Notes for Validation
Molecular Formula	C ₁₂ H ₁₀ N ₂ O ₂	MW: 214.22 g/mol
Appearance	Yellow to Orange Powder	Distinct color change from the pale/white aldehyde starting material.[1]
Melting Point	98–100 °C	Sharp melting point indicates high purity [1].[1]
¹ H NMR Diagnostic	δ 8.27 ppm (s, 1H)	The vinylic proton signal is the primary marker for conversion. Absence of aldehyde peak (~10.4 ppm) confirms completion [2].[1]
Solubility	Soluble in CHCl ₃ , DMSO, Acetone	Poor solubility in water facilitates precipitation-based isolation.

Methodological Comparison

Feature	Method A: Classical Base-Catalyzed [1]	Method B: Green Lewis Acid (SMA) [2]
Catalyst	Piperidine (Organic Base)	Silicomolybdic Acid (Heteropolyacid)
Solvent	Ethanol (or DMF)	Ethanol : Water (1:[1]1)
Conditions	Reflux (80°C), 2–3 hours	Room Temperature, ~30 mins
Yield	78–83%	85%
Scalability	High (Industrial standard)	Moderate (Catalyst recovery required)
Green Metric	Moderate (Organic base waste)	Excellent (Aqueous media, reusable catalyst)
Reproducibility	High - Robust against moisture.[1]	Moderate - pH sensitive; requires precise catalyst prep. [1]

Detailed Experimental Protocols

Protocol A: Classical Piperidine-Catalyzed Synthesis (Robust)

Recommended for first-time synthesis or when absolute reliability is prioritized over green metrics.[1]

Reagents:

- 2,5-Dimethoxybenzaldehyde (10 mmol, 1.66 g)
- Malononitrile (10 mmol, 0.66 g)
- Ethanol (20 mL)
- Piperidine (Catalytic amount, ~3-5 drops)

Step-by-Step Workflow:

- **Dissolution:** In a 50 mL round-bottom flask, dissolve 1.66 g of 2,5-dimethoxybenzaldehyde and 0.66 g of malononitrile in 20 mL of ethanol. Stir until a clear solution is obtained.
- **Catalysis:** Add 3-5 drops of piperidine. A slight color change (yellowing) may occur immediately.^[1]
- **Reaction:** Heat the mixture to reflux (approx. 78-80°C) for 2 to 3 hours. Monitor via TLC (Hexane:EtOAc 7:3).^[1] The aldehyde spot should disappear.^[1]
- **Precipitation:** Cool the reaction mixture to room temperature. If precipitation does not occur spontaneously, cool in an ice bath.
- **Isolation:** Filter the solid precipitate under vacuum.
- **Purification:** Recrystallize the crude solid from hot ethanol or an ethanol/water mixture to yield bright yellow crystals.
- **Validation:** Confirm MP (98-100°C).

Protocol B: Green Silicomolybdic Acid (SMA) Synthesis

Recommended for high-throughput screening or environmentally conscious workflows.^[1]

Reagents:

- 2,5-Dimethoxybenzaldehyde (1 mmol)^[1]
- Malononitrile (1.2 mmol)^[1]
- Silicomolybdic Acid (SMA) (1 mol%)^[1]
- Ethanol:Water (1:1 v/v, 5 mL)

Step-by-Step Workflow:

- **Preparation:** Mix the aldehyde and malononitrile in the Ethanol:Water solvent system at room temperature.

- Catalyst Addition: Add 1 mol% of SMA to the heterogeneous mixture.
- Reaction: Stir vigorously at room temperature. The reaction is typically fast (15–30 minutes).
[1] The product will precipitate out of the aqueous medium.[1]
- Isolation: Filter the solid directly.[1] Wash the cake with water to remove the soluble SMA catalyst (which can be recovered from the filtrate).[1]
- Drying: Dry the yellow powder in a vacuum oven at 50°C.

Mechanistic & Logical Analysis

Reaction Mechanism (Knoevenagel Condensation)

The reaction proceeds via a base-catalyzed mechanism (or acid-assisted enolization in Method B).[1] The critical step is the deprotonation of malononitrile to form a carbanion, which attacks the carbonyl carbon of the aldehyde.[2]

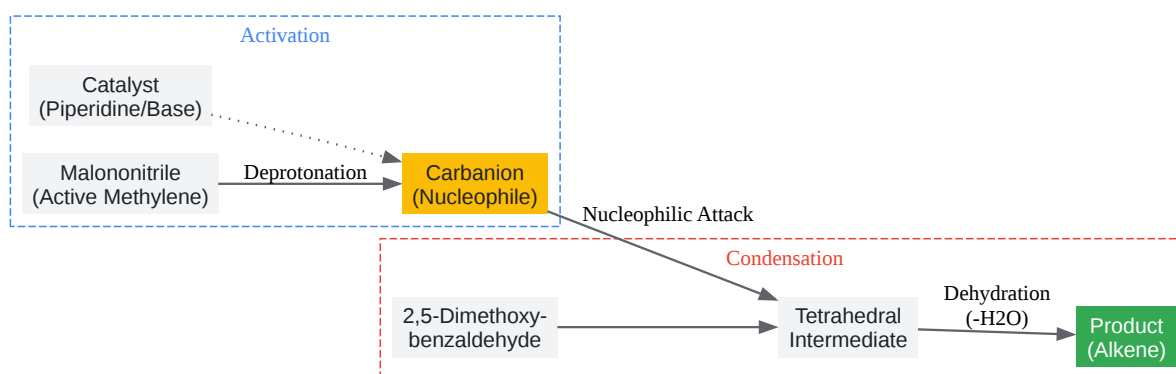

[Click to download full resolution via product page](#)

Caption: Base-catalyzed activation of malononitrile followed by nucleophilic attack and dehydration.[1][2]

Troubleshooting & Reproducibility Logic

- **Moisture Sensitivity:** While Method B uses water, the Knoevenagel reaction is reversible. In Method A (Ethanol), excess water can shift equilibrium back to the aldehyde. Ensure ethanol is dry if yield is low.^[1]
- **Isomerism:** The steric bulk of the 2,5-dimethoxy groups typically favors the E-isomer formation due to thermodynamic stability.
- **Catalyst Poisoning:** In Method B, ensure the SMA catalyst is free of contaminants; Lewis acids can be deactivated by strong coordinating bases.

Workflow Visualization

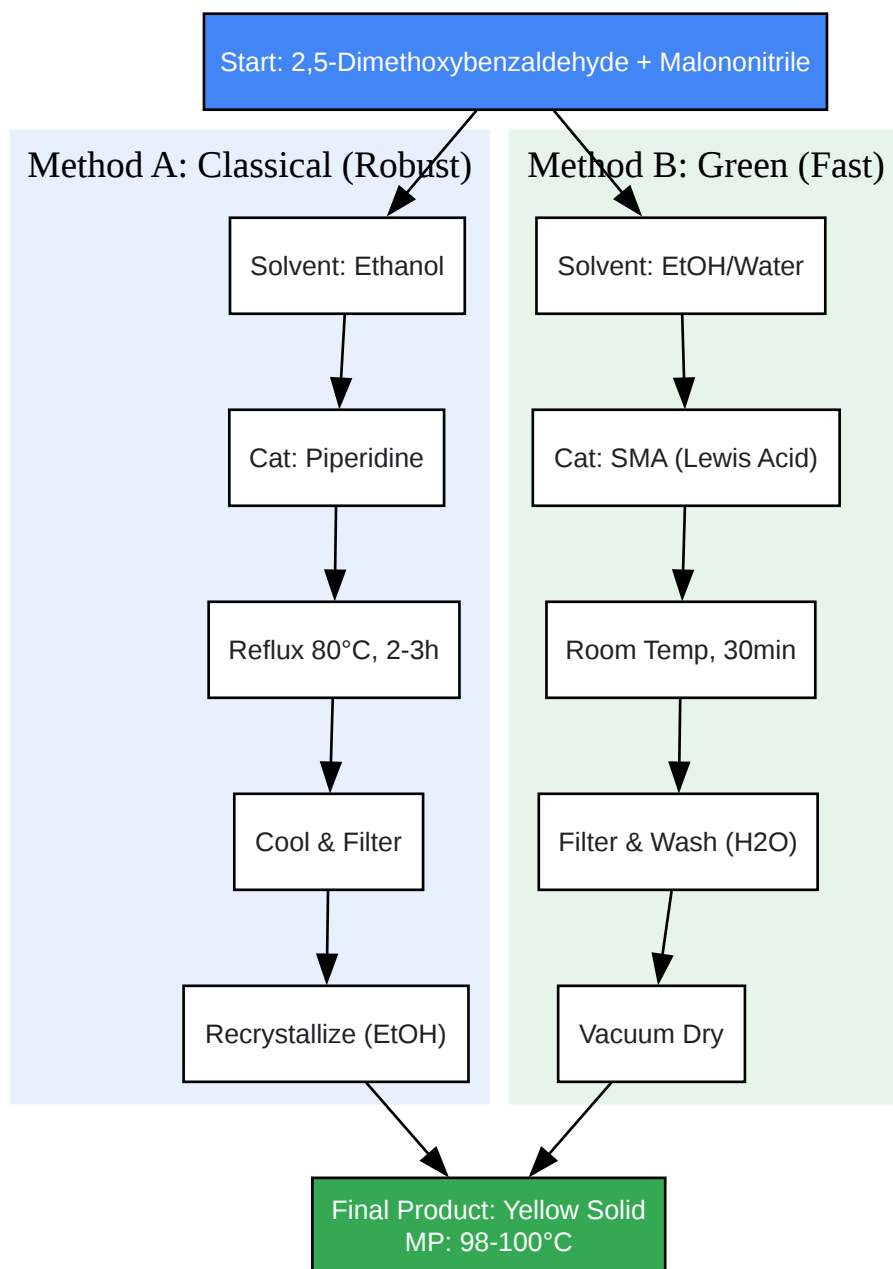

[Click to download full resolution via product page](#)

Caption: Comparative workflow for Classical (Left) vs. Green (Right) synthesis pathways.

References

- Design, synthesis, and evaluation of some newly synthesized pyranoquinolinone derivatives as potential antimicrobial agents. Pharmaspire, 2021.
 - Validates Method A, Melting Point (98-100°C)

- Unveiling the catalytic potential of silicomolybdic acid in crafting diverse biologically relevant organic compounds. RSC Advances, 2025. [1]
 - Validates Method B (Green/SMA), NMR data (1H: δ 8.27 ppm)
- Knoevenagel condensation between benzaldehyde and malononitrile in the presence of various catalysts. ResearchGate (General Reference).
 - Provides context for comparative catalytic efficiency in Knoevenagel systems.

Need Custom Synthesis?

BenchChem offers custom synthesis for rare earth carbides and specific isotopic labeling.

Email: info@benchchem.com or [Request Quote Online](#).

Sources

- 1. (2,5-Dimethoxybenzylidene)propanedinitrile | C₁₂H₁₀N₂O₂ | CID 708516 - PubChem [pubchem.ncbi.nlm.nih.gov]
- 2. (3,4-Dimethoxybenzylidene)malononitrile | 2972-80-7 | Benchchem [[benchchem.com](https://www.benchchem.com)]
- To cite this document: BenchChem. [Reproducibility of published synthesis methods for (2,5-Dimethoxybenzylidene)propanedinitrile]. BenchChem, [2026]. [Online PDF]. Available at: [<https://www.benchchem.com/product/b3025324/docs#reproducibility-of-published-synthesis-methods-for-2-5-dimethoxybenzylidene-propanedinitrile>]

Disclaimer & Data Validity:

The information provided in this document is for Research Use Only (RUO) and is strictly not intended for diagnostic or therapeutic procedures. While BenchChem strives to provide accurate protocols, we make no warranties, express or implied, regarding the fitness of this product for every specific experimental setup.

Technical Support: The protocols provided are for reference purposes. Unsure if this reagent suits your experiment?

Need Industrial/Bulk Grade? [Request Custom Synthesis Quote](#)

BenchChem

Our mission is to be the trusted global source of essential and advanced chemicals, empowering scientists and researchers to drive progress in science and industry.

Contact

Address: 3281 E Guasti Rd

Ontario, CA 91761, United States

Phone: (601) 213-4426

Email: info@benchchem.com

[Contact our Ph.D. Support Team for a compatibility check](#)