

Process Development Guide: Large-Scale Synthesis of (Dicyclopropylmethyl)amine Hydrochloride

Author: BenchChem Technical Support Team. **Date:** May 2026

Compound of Interest

Compound Name:	(Dicyclopropylmethyl)amine Hydrochloride
CAS No.:	51043-72-2
Cat. No.:	B3025387

[Get Quote](#)

Executive Summary & Strategic Analysis

(Dicyclopropylmethyl)amine is a critical pharmacophore found in antiviral fusion inhibitors and CNS-active agents. Its steric bulk and metabolic stability, provided by the twin cyclopropyl rings, make it a valuable but challenging intermediate.

The Scale-Up Challenge

The primary difficulty in scaling this synthesis is the chemo-stability of the cyclopropyl rings. These strained rings (approx.^[1] 27.5 kcal/mol strain energy) are susceptible to acid-catalyzed ring opening and thermal degradation at temperatures exceeding 100°C.

Route Selection: The "Oxime-Reduction" Strategy

While direct reductive amination (Leuckart-Wallach) is common for simple ketones, it requires high temperatures (180°C+) that risk ring degradation. We utilize a Two-Step Oxime Reduction

pathway. This route offers superior impurity control and operates under milder conditions ().

Parameter	Route A: Leuckart Reaction	Route B: Direct Reductive Amination	Route C: Oxime Reduction (Selected)
Conditions	Harsh (, Formic Acid)	Moderate (Hydride reagents)	Mild (, Pressure)
Scalability	High, but high impurity profile	Low (Stoichiometric boron waste)	High (Catalytic, clean workup)
Safety	CO evolution, Pressure	evolution, Boron toxicity	handling (Standard Engineering Control)
Purity	85-90% (requires distillation)	>95%	>98% (via crystallization)

Reaction Scheme & Process Logic

The synthesis proceeds from commercially available Dicyclopropyl ketone.

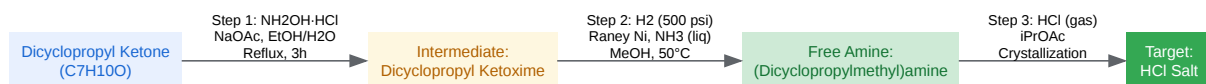

[Click to download full resolution via product page](#)

Figure 1: Synthetic pathway designed for minimal thermal stress on cyclopropyl rings.

Detailed Experimental Protocols

Step 1: Synthesis of Dicyclopropyl Ketoxime

Objective: Quantitative conversion of ketone to oxime while managing pH to prevent ring opening.

- Reagents:
 - Dicyclopropyl ketone (1.0 eq)
 - Hydroxylamine hydrochloride (1.2 eq)
 - Sodium Acetate trihydrate (1.5 eq)
 - Solvent: Ethanol/Water (3:1 v/v)

Protocol:

- Charge: To a glass-lined reactor, charge Ethanol/Water mixture and Sodium Acetate. Stir until dissolved.
- Addition: Add Hydroxylamine HCl. The solution is endothermic; allow to equilibrate to 20°C.
- Substrate Loading: Add Dicyclopropyl ketone in a single portion.
- Reaction: Heat to mild reflux (approx. 78°C). Monitor by GC/TLC.
 - Critical Control: Do not exceed 85°C jacket temperature.
- Workup: Upon completion (>99% conversion, typically 3-4h), distill off Ethanol under reduced pressure.
- Extraction: Add MTBE (Methyl tert-butyl ether) and Water. Separate phases. Wash organic layer with brine.
- Isolation: Concentrate the organic layer to yield the crude oxime as a viscous oil or low-melting solid.
 - Yield Expectation: 92-96%.

Step 2: Catalytic Hydrogenation (The Critical Step)

Objective: Reduction of the C=N bond without reducing the cyclopropyl rings. Safety Note: Raney Nickel is pyrophoric. Handle under inert atmosphere (Argon/Nitrogen) at all times.

- Reagents:
 - Crude Dicyclopropyl ketoxime (1.0 eq)
 - Raney Nickel (Type 2800 or similar, 10 wt% loading)
 - Ammonia (7N in Methanol or liquid NH₃) – Crucial for selectivity
 - Solvent: Methanol^[2]

Protocol:

- Catalyst Loading: In a glovebox or under strict purge, charge Raney Nickel (slurry in water/methanol) into the high-pressure autoclave.
- Substrate Prep: Dissolve the Ketoxime in Methanol containing Ammonia (approx. 5-10 eq of).
 - Mechanism:^{[3][4][5][6]} Excess ammonia suppresses the formation of the secondary amine dimer () by shifting the equilibrium away from the intermediate imine condensation.
- Pressurization: Seal reactor. Purge with (3x) and (3x). Pressurize to 500 psi (35 bar).
- Reaction: Heat to 50°C. Stir vigorously (gas-liquid mass transfer limited).
 - Endpoint: Uptake of Hydrogen ceases. Reaction typically takes 6-12 hours.
- Filtration: Cool to RT. Vent

- . Filter catalyst through a Celite pad under inert blanket. Do not let the catalyst dry out.
- Concentration: Carefully concentrate the filtrate to remove Methanol and excess Ammonia.
 - Caution: The free amine is volatile. Do not apply high vacuum at high temperatures.

Step 3: Salt Formation & Purification

Objective: Isolate the stable HCl salt and reject non-basic impurities.

- Reagents:
 - Crude (Dicyclopropylmethyl)amine[4]
 - HCl (4M in Dioxane or anhydrous gas)
 - Solvent: Isopropyl Acetate (iPrOAc) or Ethyl Acetate

Protocol:

- Dissolution: Dissolve crude amine in iPrOAc (10 volumes). Cool to 0-5°C.
- Acidification: Slowly bubble HCl gas or drip HCl/Dioxane into the solution. Maintain temp <20°C.
 - Observation: A thick white precipitate will form immediately.
- pH Control: Continue addition until pH of the supernatant is acidic (pH 2-3).
- Aging: Stir the slurry at 0°C for 2 hours to ripen the crystals.
- Filtration: Filter the white solid. Wash cake with cold iPrOAc and then Hexanes.
- Drying: Vacuum dry at 40°C.
 - Final Yield: 80-85% (from Ketone).[3]
 - Purity: >99% (HPLC).

Process Flow & Unit Operations

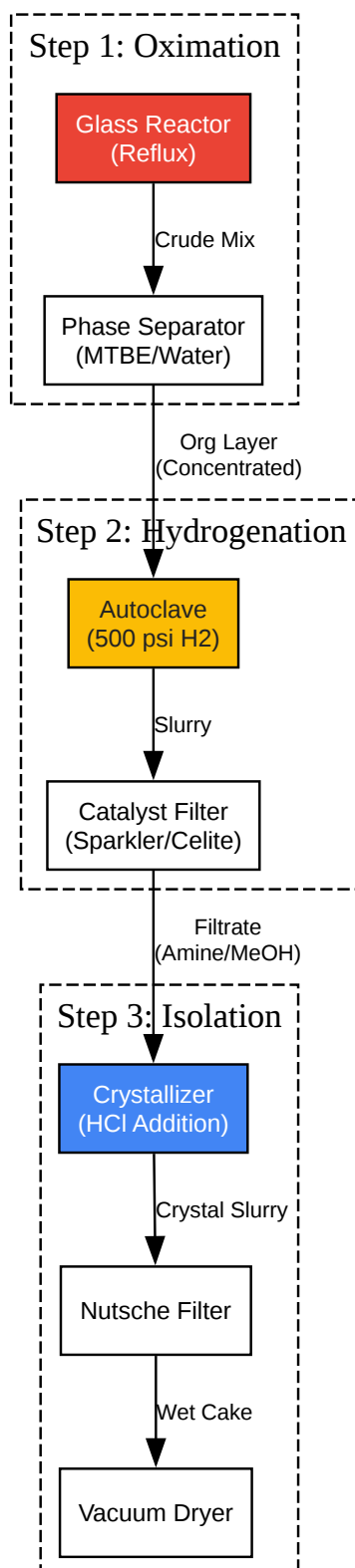

[Click to download full resolution via product page](#)

Figure 2: Unit operation workflow for the kilogram-scale production batch.

Analytical Specifications & Troubleshooting Quality Control Table

Test	Method	Specification	Failure Mode Analysis
Appearance	Visual	White crystalline solid	Yellowing indicates oxidation or residual oxime.
Identification	¹ H-NMR	Conforms to structure	Check for cyclopropyl ring signals (0.2-0.6 ppm).
Purity	HPLC (C18)	> 98.5% area	Main impurity: Dicyclopropyl ketone (unreacted).
Secondary Amine	GC-FID	< 0.5%	Caused by insufficient Ammonia during hydrogenation.
Water Content	KF	< 0.5%	Hygroscopic salt; ensure proper drying.

Troubleshooting Guide

- Problem: Low yield in Step 2 (Hydrogenation).
 - Root Cause:[1][3][4][5][6][7][8] Catalyst poisoning or insufficient pressure.
 - Fix: Ensure Ketoxime is sulfur-free. Increase pressure to 800 psi.
- Problem: "Gummy" precipitate in Step 3.
 - Root Cause:[1][3][4][5][6][7][8] Presence of water or alcohols during salt formation.

- Fix: Ensure the crude amine is dry (azeotrope with toluene if necessary) before adding HCl. Use anhydrous solvents.

References

- General Reductive Amination Reviews: Tripathi, R. P., et al. "Recent advances in the reductive amination of carbonyl compounds." *Current Organic Chemistry* 12.13 (2008): 1093-1115.
- Cyclopropyl Amine Synthesis (Oxime Route)
 - Nayal, O. S., et al. "Chemoselective Reductive Amination of Carbonyl Compounds." [8] *J. Org. Chem.* 2015, 80, 5912-5918. [8] [Link](#)
- Catalytic Hydrogenation Specifics: Grossman, R. B. *The Art of Writing Reasonable Organic Reaction Mechanisms*. (Context on imine reduction selectivity).
- Safety Data (Raney Nickel)
 - W.R. Grace & Co. "Raney Nickel Catalyst Handling Guide." [Link](#)

Disclaimer: This protocol involves hazardous materials (High-pressure Hydrogen, Raney Nickel, HCl gas). [4] All procedures must be performed in a properly equipped facility by trained personnel.

Need Custom Synthesis?

BenchChem offers custom synthesis for rare earth carbides and specific isotopic labeling.

Email: info@benchchem.com or [Request Quote Online](#).

Sources

- 1. longdom.org [longdom.org]
- 2. US4590292A - Process for the manufacture of cyclopropylamine - Google Patents [patents.google.com]
- 3. US3847985A - Process for the preparation of cyclopropylmethyl alkyl amines - Google Patents [patents.google.com]

- [4. CN106631824B - Synthesis method of \(1-cyclopropyl-1-methyl\) ethylamine hydrochloride - Google Patents \[patents.google.com\]](#)
- [5. scholar.utc.edu \[scholar.utc.edu\]](#)
- [6. researchgate.net \[researchgate.net\]](#)
- [7. researchgate.net \[researchgate.net\]](#)
- [8. Amine synthesis by reductive amination \(reductive alkylation\) \[organic-chemistry.org\]](#)
- To cite this document: BenchChem. [Process Development Guide: Large-Scale Synthesis of (Dicyclopropylmethyl)amine Hydrochloride]. BenchChem, [2026]. [Online PDF]. Available at: [\[https://www.benchchem.com/product/b3025387/docs#process-development-guide-large-scale-synthesis-of-dicyclopropylmethyl-amine-hydrochloride\]](https://www.benchchem.com/product/b3025387/docs#process-development-guide-large-scale-synthesis-of-dicyclopropylmethyl-amine-hydrochloride)

Disclaimer & Data Validity:

The information provided in this document is for Research Use Only (RUO) and is strictly not intended for diagnostic or therapeutic procedures. While BenchChem strives to provide accurate protocols, we make no warranties, express or implied, regarding the fitness of this product for every specific experimental setup.

Technical Support: The protocols provided are for reference purposes. Unsure if this reagent suits your experiment?

Need Industrial/Bulk Grade? [Request Custom Synthesis Quote](#)

BenchChem

Our mission is to be the trusted global source of essential and advanced chemicals, empowering scientists and researchers to drive progress in science and industry.

Contact

Address: 3281 E Guasti Rd

Ontario, CA 91761, United States

Phone: (601) 213-4426

Email: info@benchchem.com

Contact our Ph.D. Support Team for a compatibility check