

Application Note: Analysis of Callosobruchusic Acid by Gas Chromatography-Mass Spectrometry (GC-MS)

Author: BenchChem Technical Support Team. **Date:** April 2026

Compound of Interest

Compound Name: *Callosobruchusic acid*

Cat. No.: B3025743

[Get Quote](#)

Audience: Researchers, scientists, and drug development professionals.

Introduction

Callosobruchusic acid, a unique dicarboxylic acid, has been identified as a component in the reproductive biology of certain insects. Its analysis is crucial for understanding insect physiology and for potential applications in pest management and drug development. Gas Chromatography-Mass Spectrometry (GC-MS) is a powerful analytical technique for the separation, identification, and quantification of volatile and semi-volatile compounds. However, due to the low volatility of carboxylic acids like **Callosobruchusic acid**, a derivatization step is necessary to convert the analyte into a more volatile form suitable for GC-MS analysis. This application note provides a detailed protocol for the derivatization and subsequent GC-MS analysis of **Callosobruchusic acid**.

Experimental Protocols

1. Sample Preparation and Extraction

This protocol outlines a general procedure for extracting **Callosobruchusic acid** from a biological matrix. The specific steps may need optimization depending on the sample type.

- Materials:
 - Biological sample (e.g., insect tissue, secretions)
 - Methanol
 - Chloroform
 - Deionized water
 - Sodium sulfate (anhydrous)
 - Centrifuge
 - Vortex mixer
 - Rotary evaporator or nitrogen stream evaporator
- Procedure:
 - Homogenize the biological sample in a methanol/chloroform/water (2:1:0.8, v/v/v) solution.
 - Vortex the mixture vigorously for 10 minutes.
 - Centrifuge the homogenate at 3000 x g for 10 minutes to separate the layers.
 - Carefully collect the upper aqueous-methanolic layer, which contains the polar metabolites including **Callosobruchusic acid**.
 - Dry the collected supernatant under a gentle stream of nitrogen or using a rotary evaporator.
 - The dried extract is now ready for derivatization.

2. Derivatization: Trimethylsilylation

To increase the volatility of **Callosobruchusic acid** for GC-MS analysis, a trimethylsilylation (TMS) derivatization is performed. This reaction replaces the acidic protons of the carboxylic acid groups with trimethylsilyl groups.

- Materials:
 - Dried sample extract
 - N,O-Bis(trimethylsilyl)trifluoroacetamide (BSTFA) with 1% Trimethylchlorosilane (TMCS)
 - Pyridine (anhydrous)
 - Heating block or oven
 - GC vials with inserts
- Procedure:
 - Reconstitute the dried sample extract in 50 μ L of anhydrous pyridine.
 - Add 100 μ L of BSTFA with 1% TMCS to the sample solution in the GC vial.
 - Cap the vial tightly and vortex for 1 minute.
 - Heat the mixture at 70°C for 60 minutes to ensure complete derivatization.
 - Cool the vial to room temperature before GC-MS analysis.

3. GC-MS Analysis

The following are typical GC-MS parameters for the analysis of derivatized organic acids. Instrument conditions may require optimization.

- Instrumentation:
 - Gas Chromatograph coupled to a Mass Spectrometer (e.g., Agilent 7890A GC with 5975C MS)

- Capillary Column: HP-5MS (30 m x 0.25 mm i.d., 0.25 µm film thickness) or equivalent non-polar column.
- GC Conditions:
 - Injector Temperature: 280°C
 - Injection Mode: Splitless
 - Injection Volume: 1 µL
 - Carrier Gas: Helium at a constant flow rate of 1.0 mL/min
 - Oven Temperature Program:
 - Initial temperature: 80°C, hold for 2 minutes
 - Ramp: 10°C/min to 280°C
 - Hold at 280°C for 5 minutes
- MS Conditions:
 - Ion Source Temperature: 230°C
 - Quadrupole Temperature: 150°C
 - Ionization Mode: Electron Ionization (EI) at 70 eV
 - Mass Range: m/z 50-650
 - Scan Mode: Full Scan for qualitative analysis and Selected Ion Monitoring (SIM) for quantitative analysis.

Data Presentation

Quantitative analysis of **Callosobruchus acid** can be performed by creating a calibration curve using a certified standard of the derivatized compound. The peak area of a characteristic ion is plotted against the concentration.

Table 1: Hypothetical Quantitative GC-MS Data for Derivatized **Callosobruchus** Acid

Parameter	Value
Analyte	Bis(trimethylsilyl) Callosobruchusate
Retention Time (min)	15.8
Characteristic Ions (m/z)	Quantitative Ion: 345 [M-15]+Qualitative Ions: 73, 147, 257
Linear Range	0.1 - 50 µg/mL
Correlation Coefficient (r ²)	> 0.995
Limit of Detection (LOD)	0.05 µg/mL
Limit of Quantification (LOQ)	0.15 µg/mL

Visualizations

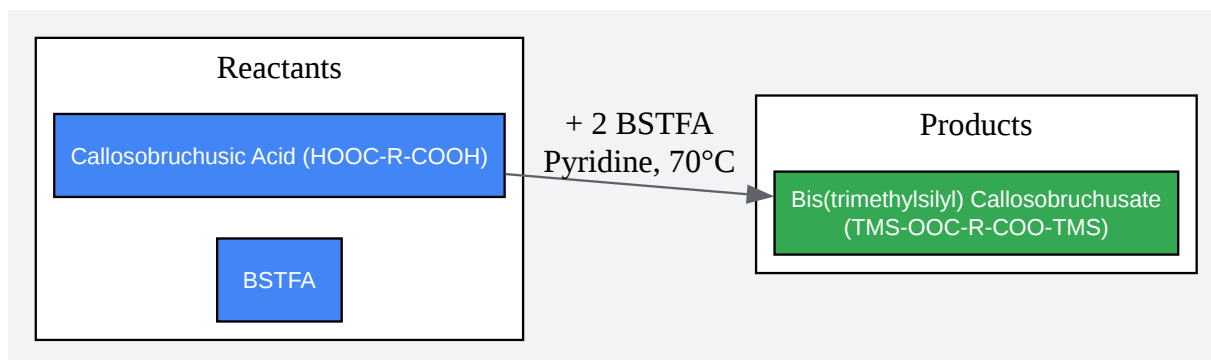
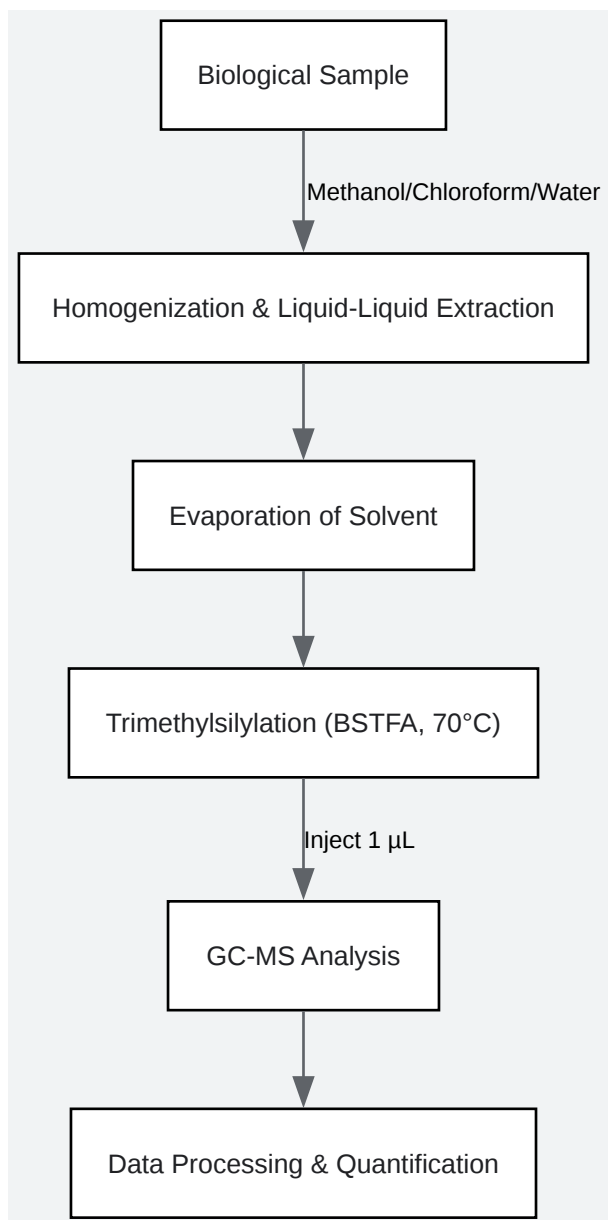

[Click to download full resolution via product page](#)

- To cite this document: BenchChem. [Application Note: Analysis of Callosobruchusic Acid by Gas Chromatography-Mass Spectrometry (GC-MS)]. BenchChem, [2026]. [Online PDF]. Available at: [<https://www.benchchem.com/product/b3025743/docs#application-note-analysis-of-callosobruchusic-acid-by-gas-chromatography-mass-spectrometry-gc-ms>]

Disclaimer & Data Validity:

The information provided in this document is for Research Use Only (RUO) and is strictly not intended for diagnostic or therapeutic procedures. While BenchChem strives to provide accurate protocols, we make no warranties, express or implied, regarding the fitness of this product for every specific experimental setup.

Technical Support: The protocols provided are for reference purposes. Unsure if this reagent suits your experiment?

Need Industrial/Bulk Grade? [Request Custom Synthesis Quote](#)

BenchChem

Our mission is to be the trusted global source of essential and advanced chemicals, empowering scientists and researchers to drive progress in science and industry.

Contact

Address: 3281 E Guasti Rd
Ontario, CA 91761, United States
Phone: (601) 213-4426
Email: info@benchchem.com

[Contact our Ph.D. Support Team for a compatibility check](#)