

A Comparative Guide to Quantitative Structure-Activity Relationship (QSAR) Studies of Propiophenone Derivatives

Author: BenchChem Technical Support Team. **Date:** April 2026

Compound of Interest

Compound Name:	2',5'-Dimethyl-3-(2,4-dimethylphenyl)propiophenone
CAS No.:	898794-08-6
Cat. No.:	B3025110

[Get Quote](#)

This guide provides an in-depth comparison of various Quantitative Structure-Activity Relationship (QSAR) methodologies applied to propiophenone derivatives. It is intended for researchers, scientists, and drug development professionals seeking to understand and apply these computational techniques to accelerate the discovery of novel therapeutic agents. We will delve into the causality behind experimental choices, present detailed protocols, and offer a comparative analysis of model performance based on published data.

Introduction: The Synergy of QSAR and Propiophenone Scaffolds

Quantitative Structure-Activity Relationship (QSAR) modeling is a pivotal computational tool in modern drug discovery.[1][2] It establishes a mathematical correlation between the chemical structure of a series of compounds and their biological activity.[3][4] By quantifying how structural modifications influence a molecule's efficacy, QSAR models enable the prediction of

activity for untested compounds, thereby prioritizing synthesis, reducing costs, and minimizing the reliance on extensive laboratory and animal testing.[1][3]

Propiophenone derivatives represent a versatile class of compounds with a wide spectrum of biological activities, including promising anticancer and anticonvulsant properties.[5][6][7][8] The inherent modifiability of the propiophenone scaffold makes it an excellent candidate for lead optimization through systematic structural changes. This guide will compare the application and performance of different QSAR approaches in elucidating the structural requirements for the biological activity of these derivatives.

Comparative Analysis of QSAR Methodologies

The selection of a QSAR methodology is a critical decision that influences the interpretability and predictive power of the resulting model. While all QSAR methods aim to connect structure with activity, they differ in how they represent the molecular structure through "descriptors".[9][10]

2D-QSAR: The Foundation of Structure-Activity Correlation

2D-QSAR models are the classical approach, correlating biological activity with physicochemical properties and topological indices derived from the 2D representation of molecules.[9][11] These descriptors are relatively simple to calculate and can provide valuable insights into the properties driving activity.

- **Causality Behind Descriptor Choice:** In 2D-QSAR, descriptors are chosen to represent different facets of the molecule's character. For instance, LogP (octanol-water partition coefficient) is used to quantify lipophilicity, which is crucial for membrane permeability.[9] Electronic descriptors like HOMO/LUMO energies relate to the molecule's reactivity and ability to engage in charge-transfer interactions.[12] Topological indices capture information about molecular size, shape, and branching.[13] For propiophenone derivatives studied for anticancer activity, descriptors such as electronic energy (Eelec), lipophilicity (logP), and chemical hardness (η) have been shown to play a significant role.[14]

3D-QSAR: Embracing Molecular Shape and Fields

3D-QSAR techniques offer a more detailed and spatially-aware analysis by considering the three-dimensional conformation of molecules and the fields they produce.[15][16] This approach is particularly powerful when ligand-receptor binding is the primary determinant of activity.

CoMFA is a pioneering 3D-QSAR method that correlates biological activity with the steric (Lennard-Jones) and electrostatic (Coulomb) fields surrounding a set of aligned molecules.[16][17] The underlying principle is that differences in the shape and electronic character of these fields are responsible for variations in binding affinity to a biological target.[17]

- **Expert Insight:** The most critical and challenging step in any 3D-QSAR study is achieving a reliable molecular alignment. The alignment hypothesis dictates that all molecules in the dataset bind to the receptor in a similar orientation. A poor alignment will inevitably lead to a non-predictive model.

CoMSIA is an extension of CoMFA that introduces additional descriptor fields: hydrophobic, hydrogen bond donor, and hydrogen bond acceptor.[16] It uses a Gaussian function to calculate similarity indices at each grid point, which results in smoother contour maps and a reduced sensitivity to small shifts in alignment compared to CoMFA.[16]

- **Performance Comparison:** For a series of phenyl alkyl ketone derivatives, CoMSIA models demonstrated greater robustness, as indicated by higher cross-validated correlation coefficient (R^2_{cv} or q^2) values, compared to CoMFA models.[18] This suggests that for certain datasets, the additional fields provided by CoMSIA can capture more relevant information for predicting biological activity. The choice between CoMFA and CoMSIA often depends on the specific nature of the ligand-receptor interactions. If hydrophobic and hydrogen bonding interactions are known to be critical, CoMSIA is likely the superior choice.

The Crucial Role of Model Validation

A QSAR model's utility is entirely dependent on its ability to make accurate predictions for new, untested compounds.[19] Therefore, rigorous validation is arguably the most important step in the QSAR workflow.[20][21] The Organisation for Economic Co-operation and Development (OECD) has established principles for the validation of QSAR models to ensure their reliability.[22]

- **Internal Validation:** This process assesses the robustness of the model using the training set data. The most common technique is leave-one-out (LOO) cross-validation, which generates the cross-validated correlation coefficient (q^2 or R^2_{cv}).^[15] A q^2 value greater than 0.5 is generally considered indicative of a robust model.^{[19][21]}
- **External Validation:** This is the ultimate test of a model's predictive power.^[20] The model is used to predict the activity of an external test set of compounds that were not used during model development. The predictive ability is quantified by the predictive r^2 (R^2_{pred}). An R^2_{pred} value greater than 0.6 is often required for a model to be considered predictive.^{[19][21]}
- **Y-Randomization:** This test ensures the model is not the result of a chance correlation. The biological activity data is shuffled randomly, and a new QSAR model is built. This process is repeated multiple times. If the resulting models have significantly lower q^2 and r^2 values than the original model, it confirms that the original model is statistically significant.^[19]

Quantitative Data Summary

The following table summarizes the performance of various QSAR models applied to propiophenone and related derivatives, providing a comparative overview of their predictive capabilities.

Study/Reference	Biological Activity	QSAR Method	Key Statistical Parameters	Noteworthy Findings
Phenylpropionone Derivatives[5][6]	Anticancer	2D-QSAR, 3D-QSAR (PLS)	Not specified in abstract	Identified key molecular descriptors and pharmacophores for enhanced anticancer activity.
Phenyl Alkyl Ketones[18]	PDE4 Inhibition	3D-QSAR (CoMFA, CoMSIA)	CoMFA: $q^2=0.7582$, $R^2_{pred}=0.9630$; CoMSIA: $q^2=0.8539$, $R^2_{pred}=0.9470$	CoMSIA model showed higher robustness (q^2). Both models had excellent predictive ability.
Aminobenzothiazole Derivatives[7]	Anticonvulsant	3D-QSAR (PHASE)	$r^2=0.9220$, $q^2=0.8144$	The model demonstrated good predictive power, aiding in the design of potent anticonvulsant agents.
Pteridinone Derivatives[23]	PLK1 Inhibition (Anticancer)	3D-QSAR (CoMFA, CoMSIA)	CoMFA: $q^2=0.67$, $R^2_{pred}=0.683$; CoMSIA: $q^2=0.66$, $R^2_{pred}=0.767$	Both models were satisfactory, with the CoMSIA model showing slightly better external predictivity.

Experimental Protocols & Workflows

This section provides a standardized, step-by-step methodology for conducting a 3D-QSAR (CoMFA/CoMSIA) study, a common and powerful approach for propiophenone derivatives.

Step-by-Step 3D-QSAR Workflow

- Data Set Preparation:
 - Compile a dataset of propiophenone derivatives with their corresponding biological activities (e.g., IC_{50} , ED_{50}).
 - Convert biological activity data to a logarithmic scale (e.g., $pIC_{50} = -\log(IC_{50})$) to ensure a linear relationship with free energy changes.
 - Divide the dataset into a training set (typically 70-80% of the compounds) for model generation and a test set (20-30%) for external validation.^[20] Ensure that the test set compounds have a range of activities and structural diversity representative of the entire dataset.
- Molecular Modeling and Alignment:
 - Draw the 2D structures of all compounds using chemical drawing software.
 - Convert the 2D structures to 3D and perform energy minimization using a suitable force field (e.g., MMFF94) or quantum mechanical method.
 - Crucial Step: Align all molecules in the training and test sets. This can be done by superimposing them onto a common template structure (e.g., the most active compound) or by using pharmacophore features. The quality of the alignment directly impacts the model's performance.
- Generation of Molecular Fields (CoMFA/CoMSIA):
 - Place the aligned molecules within a 3D grid box.
 - For CoMFA, calculate the steric (Lennard-Jones) and electrostatic (Coulomb) interaction energies at each grid point using a probe atom (typically a sp^3 carbon atom with a +1 charge).^[17]
 - For CoMSIA, calculate similarity indices for steric, electrostatic, hydrophobic, H-bond donor, and H-bond acceptor fields using a Gaussian function.^[16]

- Statistical Analysis (PLS Regression):
 - The calculated field values serve as the independent variables, and the biological activity (pIC_{50}) is the dependent variable.
 - Use Partial Least Squares (PLS) regression to build a linear relationship between the field values and the biological activity.^[5] PLS is well-suited for handling datasets with more variables than observations and where variables are intercorrelated.
 - Perform a LOO cross-validation during PLS analysis to determine the optimal number of components and to calculate the q^2 value.
- Model Validation and Interpretation:
 - Internal Validation: Assess the calculated q^2 value. A value > 0.5 indicates good robustness.^[19]
 - External Validation: Use the generated model to predict the pIC_{50} values for the test set compounds. Calculate the R^2_{pred} value to assess the model's predictive power.
 - Visualization: Generate CoMFA/CoMSIA contour maps. These maps visualize regions in 3D space where modifications to the molecular fields are predicted to increase or decrease biological activity, providing direct guidance for designing more potent molecules.^{[23][24]}

Visualizing the QSAR Process

Diagrams are essential for conceptualizing complex workflows. The following Graphviz diagrams illustrate the logical flow of a QSAR study.

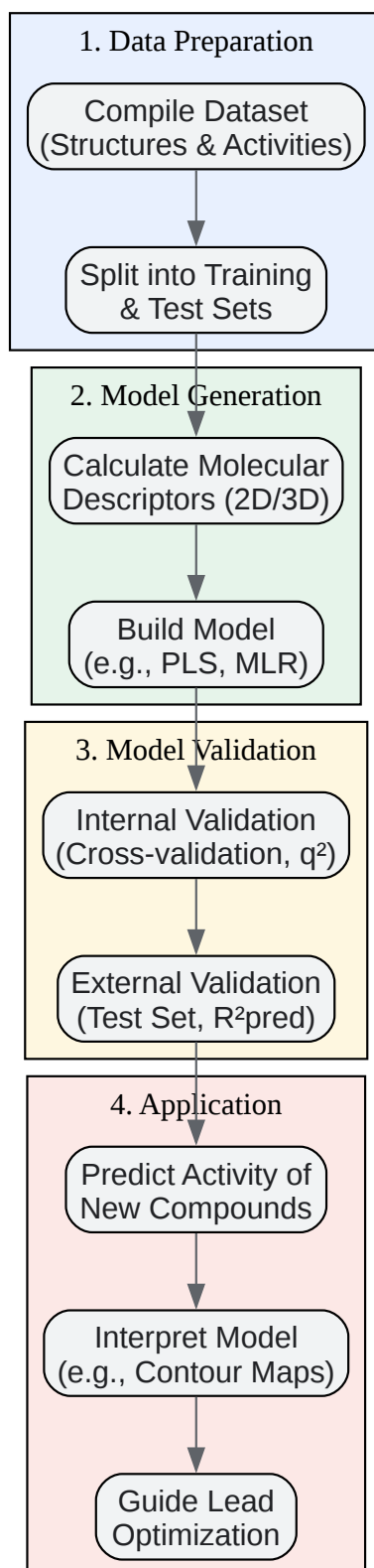

[Click to download full resolution via product page](#)

Caption: A generalized workflow for a predictive QSAR study.

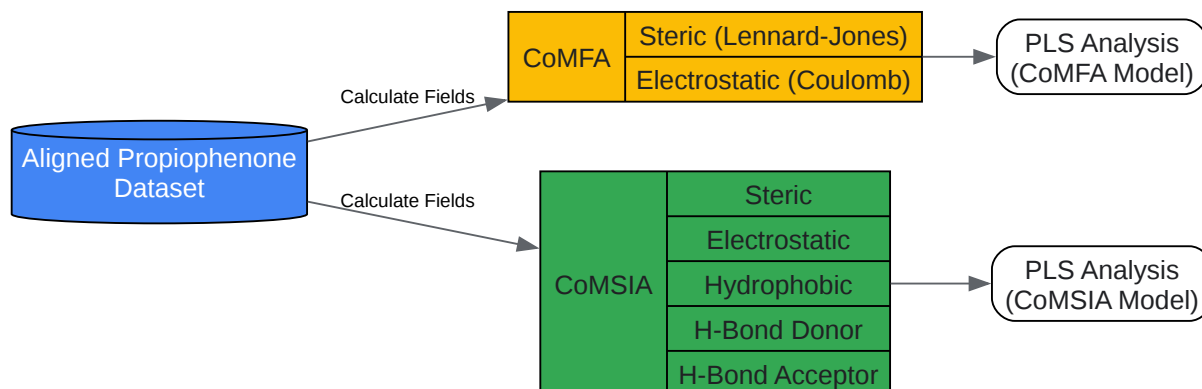

[Click to download full resolution via product page](#)

Caption: Comparison of descriptor fields in CoMFA and CoMSIA.

Conclusion and Future Perspectives

QSAR studies have proven to be an invaluable asset in the exploration of propiophenone derivatives for various therapeutic applications. 3D-QSAR methods like CoMFA and CoMSIA, in particular, provide detailed, spatially-resolved insights that can effectively guide the rational design of more potent and selective compounds. The choice between different QSAR methodologies should be guided by the specific research question and the nature of the available data.

The future of QSAR modeling will likely see an increased integration of machine learning and artificial intelligence techniques, which can capture complex, non-linear relationships between structure and activity. As computational power grows and more high-quality biological data becomes available, these advanced in-silico methods will continue to shorten the timeline and reduce the cost of bringing novel propiophenone-based drugs from the laboratory to the clinic.

References

- Validation Strategies for Robust Assessment of QSAR Models - ULisboa. (n.d.).
- Validation of QSAR Models - Basicmedical Key. (2016, July 18).
- QSAR Model Validation Guide. (2011, July 15). Scribd.

- Guidance Document on the Validation of (Quantitative) Structure-Activity Relationship [(Q)SAR] Models. (2014, September 3). OECD.
- What is the significance of QSAR in drug design? (2025, May 21). Patsnap Synapse.
- QSAR and 3D-QSAR Principles and applications in Drug Design (antineoplastic drugs). (n.d.). SVU Pedia.
- Best Practices for QSAR Model Development, Validation, and Exploitation. (2010, July 6).
- A Beginner's Guide to QSAR Modeling in Cheminformatics for Biopharma. (2024, August 13). Neovarsity.
- Quantitative structure (QSAR) techniques in Drug Design. (n.d.). CUTM Courseware.
- Phenylpropiophenone derivatives as potential anticancer agents: synthesis, biological evaluation and quantitative structure-activity relationship study. (2013, May 15). PubMed.
- QSAR in drug discovery (Chapter 10). (n.d.). Drug Design - Cambridge University Press & Assessment.
- Phenylpropiophenone derivatives as potential anticancer agents: Synthesis, biological evaluation and quantitative structure-activity relationship study. (2025, August 6). ResearchGate.
- 3D-QSAR. (2006, January 15). Drug Design Org.
- Synthesis, anticonvulsant activity and 3D-QSAR study of some prop-2-eneamido and 1-acetyl-pyrazolin derivatives of aminobenzothiazole. (2010, January 15). PubMed.
- 3D QSAR CoMFA/CoMSIA, molecular docking and molecular dynamics studies of fullerene-based HIV-1 PR. (n.d.).
- 3D-QSAR Studies, Molecular Docking, Molecular Dynamic Simulation, and ADMET Properties of Novel Pteridinone Derivatives as PLK1 Inhibitors for the Treatment of Prostate Cancer. (2023, January 2). MDPI.
- QSAR and 3D-QSAR studies applied to compounds with anticonvulsant activity. (2015, January 2).
- 3D QSAR Pharmacophore, CoMFA and CoMSIA Based Design and Docking Studies on Phenyl Alkyl Ketones as Inhibitors of Phosphodiesterase 4. (2012, September 15). PubMed.
- Beginner's Guide to 3D-QSAR in Drug Design. (2025, May 29). Neovarsity.
- QSAR and 3D-QSAR studies applied to compounds with anticonvulsant activity. (2015, January 15). PubMed.
- QSAR modelling and molecular docking studies for anti-cancer compounds against melanoma cell line SK-MEL-2. (2020, March 27). PMC.
- MOLECULAR DESCRIPTORS USED IN QSAR. (n.d.). HUF.
- Quantitative Structure-Activity Relationships (QSAR). (n.d.). Retro Synthetic Biology Team.
- QSAR Study and Molecular Design of Open-Chain Enaminones as Anticonvulsant Agents. (2011, December 14).
- QSAR Study of Anticonvulsant Derivatives. (2016, April 22). Scribd.

- QSAR. (2008, May 15). Drug Design Org.
- Anticancer Activities and QSAR Study of Novel Agents with a Chemical Profile of Benzimidazolyl-Retrochalcone. (n.d.). SCIRP.
- Tutorial: Molecular Descriptors in QSAR. (n.d.). UC Santa Barbara.
- Tackling descriptor intercorrelation in QSAR models. (2025, August 27). Cresset Group.
- Sar, Qsar And Docking Of Anticancer Flavonoids And Variants: A Review. (2026, January 17).

Need Custom Synthesis?

BenchChem offers custom synthesis for rare earth carbides and specific isotopic labeling.

Email: info@benchchem.com or [Request Quote Online](#).

Sources

- [1. What is the significance of QSAR in drug design? \[synapse.patsnap.com\]](#)
- [2. neovarsity.org \[neovarsity.org\]](#)
- [3. courseware.cutm.ac.in \[courseware.cutm.ac.in\]](#)
- [4. Quantitative Structure-Activity Relationships \(QSAR\) – Retro Synthetic Biology Team \[jfaulon.com\]](#)
- [5. Phenylpropiophenone derivatives as potential anticancer agents: synthesis, biological evaluation and quantitative structure-activity relationship study - PubMed \[pubmed.ncbi.nlm.nih.gov\]](#)
- [6. researchgate.net \[researchgate.net\]](#)
- [7. Synthesis, anticonvulsant activity and 3D-QSAR study of some prop-2-eneamido and 1-acetyl-pyrazolin derivatives of aminobenzothiazole - PubMed \[pubmed.ncbi.nlm.nih.gov\]](#)
- [8. QSAR and 3D-QSAR studies applied to compounds with anticonvulsant activity - PubMed \[pubmed.ncbi.nlm.nih.gov\]](#)
- [9. hufocw.org \[hufocw.org\]](#)
- [10. QSAR - Drug Design Org \[drugdesign.org\]](#)
- [11. QSAR in drug discovery \(Chapter 10\) - Drug Design \[cambridge.org\]](#)
- [12. Tutorial: Molecular Descriptors in QSAR \[people.chem.ucsb.edu\]](#)
- [13. cresset-group.com \[cresset-group.com\]](#)

- [14. Anticancer Activities and QSAR Study of Novel Agents with a Chemical Profile of Benzimidazolyl-Retrochalcone \[scirp.org\]](#)
- [15. pedia.svuonline.org \[pedia.svuonline.org\]](#)
- [16. neovarsity.org \[neovarsity.org\]](#)
- [17. 3D-QSAR - Drug Design Org \[drugdesign.org\]](#)
- [18. 3D QSAR pharmacophore, CoMFA and CoMSIA based design and docking studies on phenyl alkyl ketones as inhibitors of phosphodiesterase 4 - PubMed \[pubmed.ncbi.nlm.nih.gov\]](#)
- [19. elearning.uniroma1.it \[elearning.uniroma1.it\]](#)
- [20. Validation of QSAR Models | Basicmedical Key \[basicmedicalkey.com\]](#)
- [21. scribd.com \[scribd.com\]](#)
- [22. oecd.org \[oecd.org\]](#)
- [23. mdpi.com \[mdpi.com\]](#)
- [24. users.uoa.gr \[users.uoa.gr\]](#)
- To cite this document: BenchChem. [A Comparative Guide to Quantitative Structure-Activity Relationship (QSAR) Studies of Propiophenone Derivatives]. BenchChem, [2026]. [Online PDF]. Available at: [<https://www.benchchem.com/product/b3025110/docs#a-comparative-guide-to-quantitative-structure-activity-relationship-qsar-studies-of-propiophenone-derivatives>]

Disclaimer & Data Validity:

The information provided in this document is for Research Use Only (RUO) and is strictly not intended for diagnostic or therapeutic procedures. While BenchChem strives to provide accurate protocols, we make no warranties, express or implied, regarding the fitness of this product for every specific experimental setup.

Technical Support: The protocols provided are for reference purposes. Unsure if this reagent suits your experiment?

Need Industrial/Bulk Grade? [Request Custom Synthesis Quote](#)

BenchChem

Our mission is to be the trusted global source of essential and advanced chemicals, empowering scientists and researchers to drive progress in science and industry.

Contact

Address: 3281 E Guasti Rd

Ontario, CA 91761, United States

Phone: (601) 213-4426

Email: info@benchchem.com

[Contact our Ph.D. Support Team for a compatibility check](#)