

# theoretical and computational studies of Chroman-4-carboxylic Acid

**Author:** BenchChem Technical Support Team. **Date:** May 2026

## Compound of Interest

Compound Name: *Chroman-4-carboxylic Acid*

CAS No.: 20426-80-6

Cat. No.: B3024662

[Get Quote](#)

An In-Depth Technical Guide to the Theoretical and Computational Analysis of **Chroman-4-carboxylic Acid**

## Abstract

This technical guide provides a comprehensive framework for the multifaceted investigation of **Chroman-4-carboxylic Acid**, a heterocyclic compound of significant interest in medicinal chemistry. The chroman-4-one scaffold is a privileged structure found in numerous bioactive molecules.<sup>[1][2]</sup> This document bridges the gap between empirical laboratory synthesis and advanced in silico analysis, offering researchers and drug development professionals a cohesive protocol. We detail a robust synthetic pathway, outline rigorous spectroscopic characterization (<sup>1</sup>H NMR, <sup>13</sup>C NMR, FT-IR, UV-Vis), and provide a step-by-step guide to modern computational studies using Density Functional Theory (DFT). Furthermore, we explore the molecule's therapeutic potential through molecular docking simulations against a relevant biological target, Cyclooxygenase-2 (COX-2). The methodologies described herein are designed to be self-validating, where computational data corroborates experimental findings, ensuring a high degree of scientific integrity.

## Introduction: The Significance of the Chroman Scaffold

The chroman-4-one heterocyclic system, characterized by a benzene ring fused to a dihydropyran ring, is a foundational structure in a vast array of natural products and synthetic compounds.<sup>[1][3]</sup> Its derivatives, such as flavanones and isoflavanones, exhibit a wide spectrum of pharmacological activities, including anticancer, anti-inflammatory, antioxidant, and antimicrobial properties.<sup>[1][4]</sup> **Chroman-4-carboxylic Acid**, as a specific analogue, presents a unique combination of a rigid bicyclic core and a reactive carboxylic acid moiety, making it an attractive building block for the synthesis of novel therapeutic agents.

The synergy between experimental and computational chemistry is paramount in modern drug discovery. While synthesis and spectroscopic analysis provide tangible proof of a molecule's existence and structure, computational methods offer profound insights into its electronic properties, reactivity, and potential biological interactions at an atomic level.<sup>[5][6]</sup> This guide elucidates this synergistic workflow, demonstrating how theoretical calculations can not only predict and validate experimental results but also guide the rational design of future drug candidates.

## Synthesis and Spectroscopic Characterization

The foundation of any theoretical study is the accurate synthesis and unambiguous structural confirmation of the target molecule. This section details a reliable method for the preparation of **Chroman-4-carboxylic Acid** and the subsequent analytical techniques required for its characterization.

## Synthesis Methodology: Intramolecular Cyclization

A common and effective route to chroman-4-one derivatives involves the intramolecular cyclization of a phenolic precursor.<sup>[7]</sup> The following protocol is adapted from established methods for the synthesis of the chroman-4-one core.<sup>[7]</sup> The process begins with a Friedel-Crafts acylation of a phenol with a suitable three-carbon acid derivative, followed by a base-catalyzed ring closure.

## Experimental Protocol: Synthesis of 7-Hydroxychroman-4-one

Causality: This procedure is a precursor to obtaining the specific carboxylic acid, but establishes the core ring system. 7-Hydroxychroman-4-one is a common intermediate.[7]

- Step 1: Acylation. To a solution of resorcinol (1.0 equiv) in a suitable solvent, add 3-chloropropionic acid (1.1 equiv) and a Lewis acid catalyst (e.g., trifluoromethanesulfonic acid).
- Step 2: Reaction. Heat the mixture under reflux for 4-6 hours, monitoring the reaction progress by Thin Layer Chromatography (TLC). The Lewis acid facilitates the electrophilic substitution onto the electron-rich aromatic ring.
- Step 3: Work-up. After cooling, quench the reaction by pouring the mixture into ice water. Extract the aqueous layer with ethyl acetate. The organic layers are combined, washed with brine, dried over anhydrous  $\text{MgSO}_4$ , and concentrated under reduced pressure.
- Step 4: Cyclization. Dissolve the crude product from Step 3 in a 2 M solution of sodium hydroxide (NaOH). Stir the mixture at room temperature for 2-3 hours. The basic conditions promote an intramolecular  $\text{S}_{\text{N}}2$  reaction, where the phenoxide ion displaces the chloride, forming the heterocyclic ring.[7]
- Step 5: Purification. Neutralize the basic solution with dilute HCl to precipitate the product. Filter the solid, wash with cold water, and recrystallize from an appropriate solvent system (e.g., ethanol/water) to yield pure 7-Hydroxychroman-4-one.

Note: The synthesis of the specific **Chroman-4-carboxylic Acid** would require starting with a phenol already containing the precursor to the carboxylic acid at the desired position or subsequent modification of the chroman-4-one ring.

## Spectroscopic Analysis: Structural Elucidation

Spectroscopy is a non-destructive analytical tool essential for confirming the covalent structure of a synthesized molecule.[8][9] The data obtained serves as a benchmark for validating the results of subsequent computational calculations.

NMR spectroscopy provides detailed information about the carbon-hydrogen framework of a molecule.[10] Samples are typically dissolved in a deuterated solvent like  $\text{CDCl}_3$  or  $\text{DMSO-d}_6$ , with Tetramethylsilane (TMS) used as an internal standard.[10]

$^1\text{H}$  NMR Spectroscopy: The proton NMR spectrum will confirm the presence of aromatic and aliphatic protons. Key expected signals for a chroman-4-one structure include:

- Aromatic Protons: Signals in the range of  $\delta$  6.5-8.0 ppm, with splitting patterns determined by the substitution on the benzene ring.
- Methylene Protons (H-2): A triplet signal typically found around  $\delta$  4.5 ppm, indicative of the -O-CH<sub>2</sub>- group.[7]
- Methylene Protons (H-3): A triplet signal around  $\delta$  2.7 ppm, corresponding to the -CH<sub>2</sub>-C=O group.[7]
- Carboxylic Acid Proton: A broad singlet at  $\delta$  10-13 ppm, which is characteristic of the acidic proton of a carboxyl group.[10]

$^{13}\text{C}$  NMR Spectroscopy: The carbon NMR spectrum provides a count of unique carbon environments.

- Carbonyl Carbon (C-4): A signal in the downfield region, typically  $\delta$  185-195 ppm.[7]
- Carboxylic Acid Carbon: A signal around  $\delta$  170-185 ppm.[10]
- Aromatic Carbons: Multiple signals between  $\delta$  100-165 ppm.
- Aliphatic Carbons: Signals for C-2 (around  $\delta$  67 ppm) and C-3 (around  $\delta$  37 ppm) are characteristic of the chroman-4-one core.[7]

Assignment	Expected <sup>1</sup> H Chemical Shift (δ, ppm)	Expected <sup>13</sup> C Chemical Shift (δ, ppm)
Carboxylic Acid (-COOH)	10.0 - 13.0 (broad s)	170 - 185
Carbonyl (C=O)	-	185 - 195
Aromatic (Ar-H)	6.5 - 8.0 (m)	100 - 165
Methylene (-O-CH <sub>2</sub> )	~4.5 (t)	~67
Methylene (-CH <sub>2</sub> -C=O)	~2.7 (t)	~37

Table 1: Predicted <sup>1</sup>H and <sup>13</sup>C NMR Chemical Shifts for **Chroman-4-carboxylic Acid**.

FT-IR spectroscopy is used to identify the functional groups present in a molecule by measuring the absorption of infrared radiation.[\[9\]](#)[\[11\]](#)

Vibrational Mode	Expected Frequency (cm <sup>-1</sup> )	Significance
O-H Stretch (Carboxylic Acid)	2500 - 3300 (broad)	Confirms the presence of the -COOH group.
C-H Stretch (Aromatic)	3000 - 3100	Indicates the aromatic ring.
C-H Stretch (Aliphatic)	2850 - 3000	Indicates the -CH <sub>2</sub> - groups.
C=O Stretch (Carboxylic Acid)	1700 - 1725	Distinguishes the acid carbonyl.
C=O Stretch (Ketone)	1680 - 1700	Confirms the ketone in the pyranone ring.
C=C Stretch (Aromatic)	1450 - 1600	Aromatic ring skeletal vibrations.
C-O Stretch	1000 - 1300	Ether and carboxylic acid C-O bonds.

Table 2: Key FT-IR Vibrational Frequencies for **Chroman-4-carboxylic Acid**.

UV-Vis spectroscopy provides information about electronic transitions within the molecule.<sup>[12]</sup> Chroman-4-one derivatives typically exhibit absorption bands corresponding to  $\pi \rightarrow \pi^*$  and  $n \rightarrow \pi^*$  transitions, primarily associated with the aromatic ring and the carbonyl group.

## Computational Analysis: An In Silico Investigation

Computational chemistry provides a powerful lens to examine molecular properties that are difficult or impossible to measure experimentally.<sup>[5]</sup> Density Functional Theory (DFT) is a robust method for studying the electronic structure of molecules, offering a favorable balance between accuracy and computational cost.<sup>[13][14]</sup>

### Methodology: Density Functional Theory (DFT)

All theoretical calculations should be performed using a quantum chemistry software package like Gaussian. The B3LYP functional, a hybrid functional that combines Becke's three-parameter exchange functional with the Lee-Yang-Parr correlation functional, is widely used and provides reliable results for organic molecules.<sup>[15][16]</sup> A Pople-style basis set, such as 6-311++G(d,p), is recommended to provide sufficient flexibility for an accurate description of the molecule's electronic distribution.<sup>[15][16]</sup>

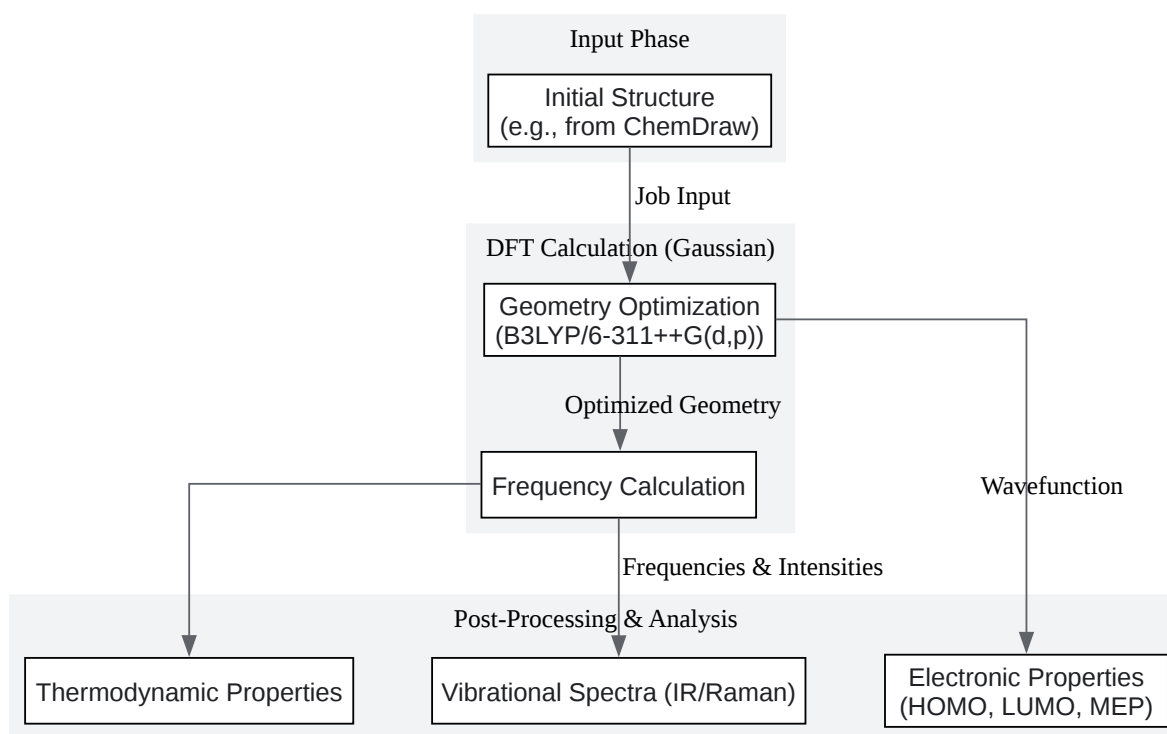

[Click to download full resolution via product page](#)

*Caption: DFT computational workflow.*

## Geometric Optimization and Vibrational Analysis

The first computational step is to find the molecule's lowest energy conformation through geometry optimization. The resulting structure provides theoretical bond lengths and angles that can be compared with crystallographic data if available.

A frequency calculation must be performed on the optimized geometry. The absence of imaginary frequencies confirms that the structure is a true energy minimum. The calculated vibrational frequencies can be scaled by an appropriate factor ( $\sim 0.967$  for B3LYP/6-311++G(d,p)) and directly compared to the experimental FT-IR spectrum. This comparison is a

critical self-validation step: a strong correlation between the theoretical and experimental spectra builds confidence in the chosen computational model.[17]

## Analysis of Electronic Properties

The Highest Occupied Molecular Orbital (HOMO) and the Lowest Unoccupied Molecular Orbital (LUMO) are key to understanding chemical reactivity. The HOMO represents the ability to donate an electron, while the LUMO represents the ability to accept an electron. The energy gap ( $\Delta E = E_{LUMO} - E_{HOMO}$ ) is an indicator of molecular stability and reactivity; a smaller gap suggests the molecule is more reactive.[13] These orbitals also govern UV-Vis absorption, as the lowest energy electronic transition is typically the HOMO  $\rightarrow$  LUMO excitation.

The MEP is a 3D map of the electrostatic potential on the molecule's surface. It is an invaluable tool for predicting reactive sites.

- Red Regions (Negative Potential): Indicate electron-rich areas, prone to electrophilic attack. These are typically found around electronegative atoms like oxygen.
- Blue Regions (Positive Potential): Indicate electron-deficient areas, prone to nucleophilic attack. These are often located around acidic hydrogen atoms.

The MEP map for **Chroman-4-carboxylic Acid** would be expected to show strong negative potential around the carbonyl and carboxylic oxygen atoms and a strong positive potential around the acidic proton of the carboxyl group.

## Molecular Docking Studies: A Pharmacological Perspective

Molecular docking is a computational technique that predicts the preferred orientation of one molecule (a ligand) when bound to a second (a receptor, typically a protein). It is a cornerstone of structure-based drug design.[18]

## Rationale and Target Selection

Given the known anti-inflammatory properties of many chromanone derivatives, Cyclooxygenase-2 (COX-2) is an excellent and highly relevant protein target.[4] COX-2 is an enzyme responsible for the synthesis of prostaglandins, which are key mediators of

inflammation. Inhibiting COX-2 is the mechanism of action for many non-steroidal anti-inflammatory drugs (NSAIDs).

## Molecular Docking Protocol

- **Step 1: Receptor Preparation.** Obtain the 3D crystal structure of human COX-2 from the Protein Data Bank (PDB; e.g., PDB ID: 1CX2). Prepare the protein by removing water molecules, adding hydrogen atoms, and assigning partial charges.
- **Step 2: Ligand Preparation.** Generate the 3D structure of **Chroman-4-carboxylic Acid** from the DFT-optimized geometry. Assign charges and define rotatable bonds.
- **Step 3: Grid Generation.** Define the active site of the COX-2 enzyme. This is typically done by creating a grid box centered on the co-crystallized ligand in the experimental structure.
- **Step 4: Docking Simulation.** Use a docking program (e.g., AutoDock, Glide) to systematically search for the best binding poses of the ligand within the receptor's active site. The program will score and rank the poses based on a scoring function that estimates the binding affinity (e.g., in kcal/mol).
- **Step 5: Analysis of Results.** Analyze the top-ranked pose to identify key intermolecular interactions, such as hydrogen bonds, hydrophobic interactions, and  $\pi$ - $\pi$  stacking, between the ligand and the amino acid residues of the active site. Visualizing the docked complex is crucial for understanding the binding mode.

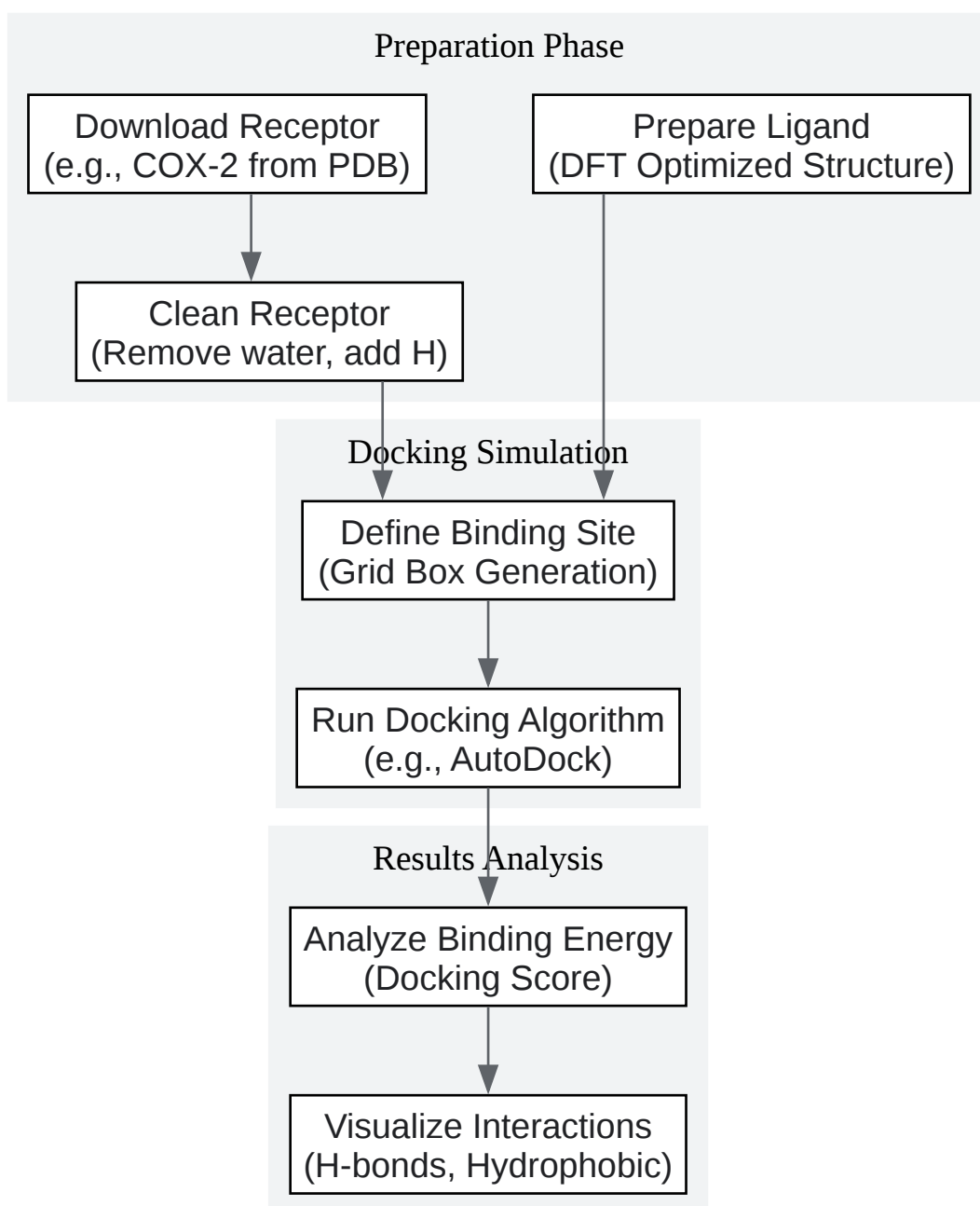

[Click to download full resolution via product page](#)

### Need Custom Synthesis?

BenchChem offers custom synthesis for rare earth carbides and specific isotopic labeling.

Email: [info@benchchem.com](mailto:info@benchchem.com) or [Request Quote Online](#).

## Sources

- [1. Chromanone-A Prerogative Therapeutic Scaffold: An Overview - PMC \[pmc.ncbi.nlm.nih.gov\]](#)
- [2. researchgate.net \[researchgate.net\]](#)
- [3. innospk.com \[innospk.com\]](#)
- [4. sciencescholar.us \[sciencescholar.us\]](#)
- [5. Computational Heterocyclic Chemistry \[ch.ic.ac.uk\]](#)
- [6. camjol.info \[camjol.info\]](#)
- [7. mdpi.com \[mdpi.com\]](#)
- [8. ijsat.org \[ijsat.org\]](#)
- [9. documents.thermofisher.com \[documents.thermofisher.com\]](#)
- [10. myneni.princeton.edu \[myneni.princeton.edu\]](#)
- [11. scispace.com \[scispace.com\]](#)
- [12. Synthesis, spectroscopic \(FT-IR, FT-Raman, NMR & UV-Vis\), reactive \(ELF, LOL, Fukui\), drug likeness and molecular docking insights on novel 4-\[3-\(3-methoxy-phenyl\)-3-oxo-propenyl\]-benzonitrile by experimental and computational methods - PMC \[pmc.ncbi.nlm.nih.gov\]](#)
- [13. researchgate.net \[researchgate.net\]](#)
- [14. Spectroscopic and computational study of chromone derivatives with antitumor activity: detailed DFT, QTAIM and docking ... \[ouci.dntb.gov.ua\]](#)
- [15. Conformational & spectroscopic characterization, charge analysis and molecular docking profiles of chromone-3-carboxylic acid using a quantum hybrid computational method - PMC \[pmc.ncbi.nlm.nih.gov\]](#)
- [16. Conformational & spectroscopic characterization, charge analysis and molecular docking profiles of chromone-3-carboxylic acid using a quantum hybrid computational method - PubMed \[pubmed.ncbi.nlm.nih.gov\]](#)
- [17. researchgate.net \[researchgate.net\]](#)
- [18. sciencescholar.us \[sciencescholar.us\]](#)
- [To cite this document: BenchChem. \[theoretical and computational studies of Chroman-4-carboxylic Acid\]. BenchChem, \[2026\]. \[Online PDF\]. Available at:](#)

[\[https://www.benchchem.com/product/b3024662/docs#theoretical-and-computational-studies-of-chroman-4-carboxylic-acid\]](https://www.benchchem.com/product/b3024662/docs#theoretical-and-computational-studies-of-chroman-4-carboxylic-acid)

### Disclaimer & Data Validity:

The information provided in this document is for Research Use Only (RUO) and is strictly not intended for diagnostic or therapeutic procedures. While BenchChem strives to provide accurate protocols, we make no warranties, express or implied, regarding the fitness of this product for every specific experimental setup.

**Technical Support:** The protocols provided are for reference purposes. Unsure if this reagent suits your experiment?

**Need Industrial/Bulk Grade?** [Request Custom Synthesis Quote](#)

## BenchChem

Our mission is to be the trusted global source of essential and advanced chemicals, empowering scientists and researchers to drive progress in science and industry.

### Contact

Address: 3281 E Guasti Rd  
Ontario, CA 91761, United States  
Phone: (601) 213-4426  
Email: [info@benchchem.com](mailto:info@benchchem.com)

[Contact our Ph.D. Support Team for a compatibility check](#)