

Comprehensive Analytical Strategies for the Characterization of Chroman-4-carboxylic Acid

Author: BenchChem Technical Support Team. **Date:** May 2026

Compound of Interest

Compound Name: *Chroman-4-carboxylic Acid*

CAS No.: 20426-80-6

Cat. No.: B3024662

[Get Quote](#)

Abstract: This document provides a comprehensive guide to the analytical methods for the characterization of **Chroman-4-carboxylic Acid**, a key intermediate in the synthesis of various pharmaceutical compounds. The protocols and discussions herein are tailored for researchers, scientists, and drug development professionals, emphasizing not just the procedural steps but also the underlying scientific principles that govern method selection and optimization. This guide is built on the pillars of expertise, trustworthiness, and authoritative scientific grounding to ensure robust and reproducible results.

Introduction: The Significance of Chroman-4-carboxylic Acid

Chroman-4-carboxylic Acid and its derivatives are pivotal structural motifs in a range of biologically active molecules. Their presence in pharmaceuticals necessitates rigorous analytical characterization to ensure identity, purity, and quality. The analytical methods detailed in this guide are designed to provide a comprehensive profile of the molecule, from its structural confirmation to the quantification of impurities.

Foundational Analytical Techniques

A multi-faceted approach is essential for the complete characterization of **Chroman-4-carboxylic Acid**. The following sections detail the primary analytical techniques and provide step-by-step protocols for their implementation.

High-Performance Liquid Chromatography (HPLC) for Purity Assessment and Quantification

HPLC is the cornerstone for assessing the purity of **Chroman-4-carboxylic Acid** and for quantifying it in various matrices. A well-developed HPLC method can separate the target analyte from its precursors, by-products, and degradation products.

The Rationale Behind Method Selection: A reversed-phase HPLC method is generally preferred due to the moderate polarity of **Chroman-4-carboxylic Acid**. The choice of a C18 column provides excellent retention and separation capabilities for this class of compounds. UV detection is suitable as the chroman moiety contains a chromophore that absorbs in the UV region.

Experimental Workflow for HPLC Analysis:

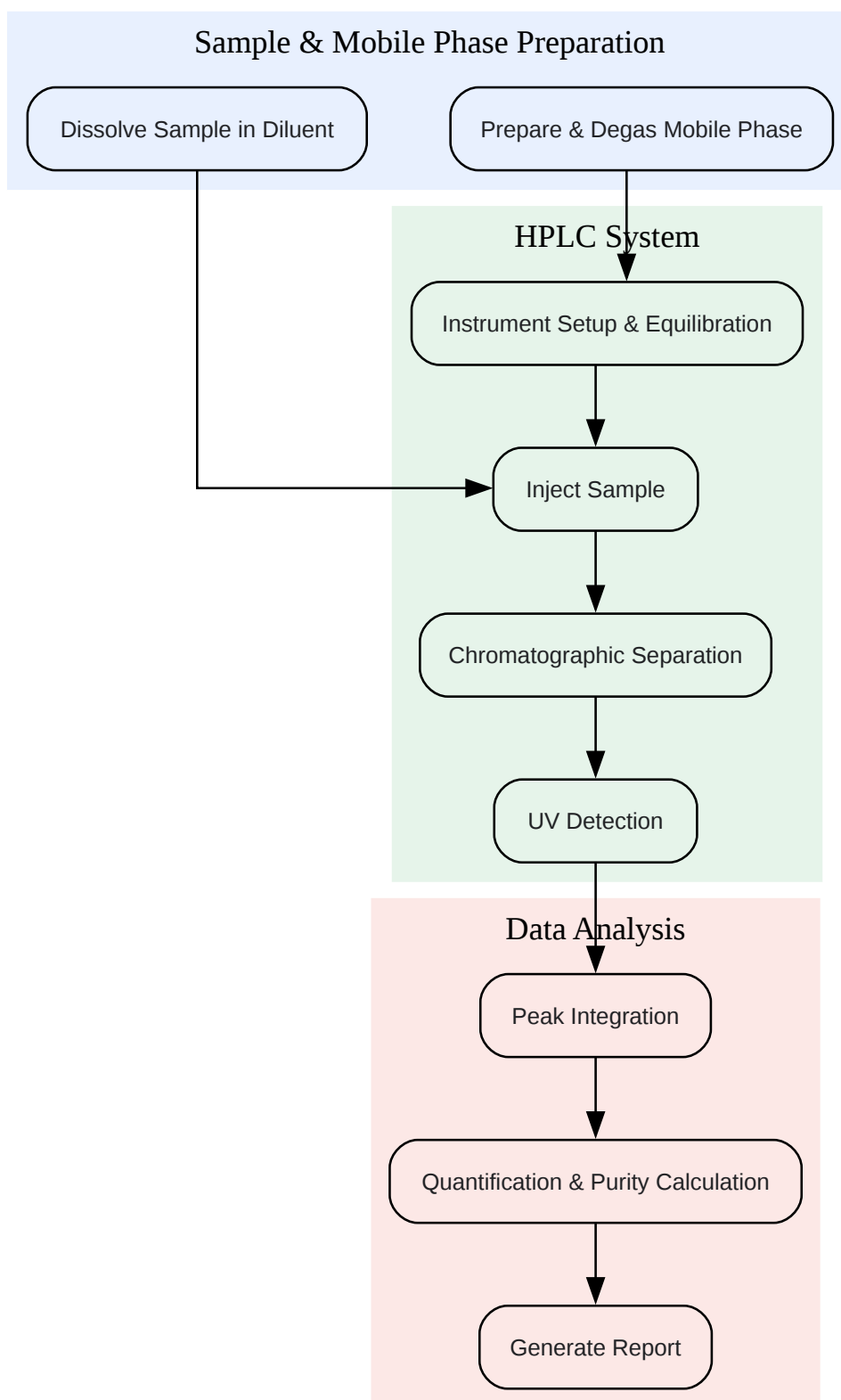

[Click to download full resolution via product page](#)

Figure 1: A generalized workflow for the HPLC analysis of **Chroman-4-carboxylic Acid**.

Detailed HPLC Protocol:

Objective: To determine the purity of a **Chroman-4-carboxylic Acid** sample and quantify the main component.

Materials and Reagents:

- **Chroman-4-carboxylic Acid** reference standard and sample
- Acetonitrile (HPLC grade)
- Water (HPLC grade)
- Formic acid (or other suitable acid for pH adjustment)
- Methanol (for sample dissolution)

Instrumentation:

- HPLC system with a quaternary or binary pump
- Autosampler
- Column oven
- UV-Vis or Diode Array Detector (DAD)
- C18 reversed-phase column (e.g., 4.6 x 150 mm, 5 μ m particle size)

Chromatographic Conditions:

Parameter	Recommended Setting
Mobile Phase A	Water with 0.1% Formic Acid
Mobile Phase B	Acetonitrile with 0.1% Formic Acid
Gradient	0-2 min: 10% B; 2-15 min: 10-90% B; 15-18 min: 90% B; 18-20 min: 10% B
Flow Rate	1.0 mL/min
Column Temperature	30 °C
Detection Wavelength	275 nm
Injection Volume	10 µL
Run Time	20 minutes

Procedure:

- **Standard Preparation:** Accurately weigh and dissolve the **Chroman-4-carboxylic Acid** reference standard in methanol to prepare a stock solution of 1 mg/mL. Further dilute to a working concentration of 0.1 mg/mL.
- **Sample Preparation:** Prepare the sample in the same manner as the standard.
- **System Equilibration:** Equilibrate the HPLC system with the initial mobile phase composition for at least 30 minutes or until a stable baseline is achieved.
- **Injection:** Inject the standard and sample solutions.
- **Data Analysis:** Integrate the peaks and calculate the purity of the sample by area normalization. For quantification, use a calibration curve generated from a series of standard solutions.

Gas Chromatography-Mass Spectrometry (GC-MS) for Volatile Impurities and Structural Confirmation

GC-MS is a powerful technique for the identification of volatile and semi-volatile impurities that may be present in the **Chroman-4-carboxylic Acid** sample. Derivatization is often necessary to increase the volatility of the carboxylic acid.

The Rationale Behind Derivatization: Carboxylic acids are polar and have low volatility, making them unsuitable for direct GC analysis. Derivatization, typically through esterification (e.g., with diazomethane or by Fischer esterification), converts the carboxylic acid into a more volatile ester, enabling its passage through the GC column.

Experimental Workflow for GC-MS Analysis:

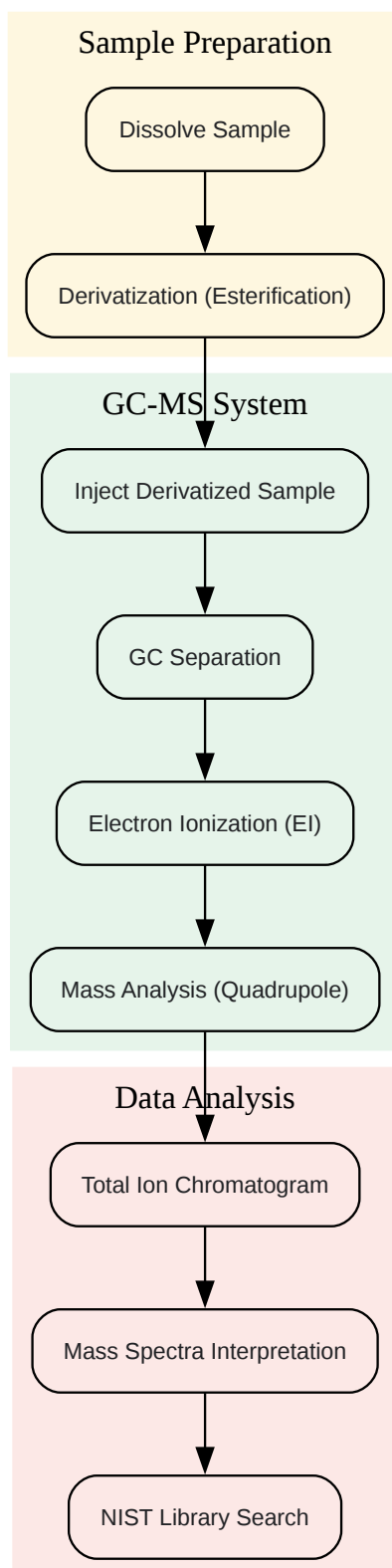

[Click to download full resolution via product page](#)

Figure 2: A typical workflow for the GC-MS analysis of **Chroman-4-carboxylic Acid** following derivatization.

Detailed GC-MS Protocol:

Objective: To identify volatile impurities and confirm the structure of **Chroman-4-carboxylic Acid** after derivatization.

Materials and Reagents:

- **Chroman-4-carboxylic Acid** sample
- Methanol (anhydrous)
- Sulfuric acid (concentrated)
- Dichloromethane (DCM)
- Sodium bicarbonate solution (saturated)
- Sodium sulfate (anhydrous)

Instrumentation:

- GC-MS system with a capillary column (e.g., DB-5ms, 30 m x 0.25 mm x 0.25 μ m)
- Electron Ionization (EI) source
- Quadrupole mass analyzer

GC-MS Conditions:

Parameter	Recommended Setting
Inlet Temperature	250 °C
Carrier Gas	Helium at a constant flow of 1.0 mL/min
Oven Program	50 °C (hold 2 min), ramp to 280 °C at 10 °C/min, hold 5 min
Ion Source Temp	230 °C
Ionization Energy	70 eV
Mass Range	40-450 amu
Solvent Delay	3 minutes

Procedure:

- Derivatization (Fischer Esterification):
 - To 10 mg of the sample, add 2 mL of anhydrous methanol and 2-3 drops of concentrated sulfuric acid.
 - Reflux the mixture for 2-3 hours.
 - After cooling, add 5 mL of DCM and wash with saturated sodium bicarbonate solution.
 - Separate the organic layer, dry over anhydrous sodium sulfate, and concentrate under a stream of nitrogen.
 - Reconstitute in a small volume of DCM for injection.
- GC-MS Analysis: Inject the derivatized sample into the GC-MS system.
- Data Analysis: Analyze the total ion chromatogram (TIC) for peaks. Obtain the mass spectrum for each peak and compare it with a library database (e.g., NIST) for identification. The mass spectrum of the methyl ester of **Chroman-4-carboxylic Acid** should show a molecular ion peak and characteristic fragmentation patterns.

Nuclear Magnetic Resonance (NMR) Spectroscopy for Unambiguous Structural Elucidation

NMR spectroscopy is an indispensable tool for the definitive structural confirmation of **Chroman-4-carboxylic Acid**. Both ^1H and ^{13}C NMR provide detailed information about the molecular structure.

The Power of NMR in Structural Analysis: ^1H NMR provides information on the number of different types of protons, their chemical environment, and their connectivity through spin-spin coupling. ^{13}C NMR provides information on the number and types of carbon atoms. Together, they allow for the complete assembly of the molecular structure.

Detailed NMR Protocol:

Objective: To confirm the chemical structure of **Chroman-4-carboxylic Acid**.

Materials and Reagents:

- **Chroman-4-carboxylic Acid** sample
- Deuterated solvent (e.g., DMSO- d_6 or CDCl_3)
- Tetramethylsilane (TMS) as an internal standard (if not already in the solvent)

Instrumentation:

- NMR spectrometer (e.g., 400 MHz or higher)

NMR Acquisition Parameters:

Parameter	¹ H NMR	¹³ C NMR
Solvent	DMSO-d ₆	DMSO-d ₆
Pulse Program	zg30	zgpg30
Number of Scans	16	1024
Relaxation Delay	1.0 s	2.0 s
Acquisition Time	~4 s	~1 s
Spectral Width	~20 ppm	~240 ppm

Procedure:

- **Sample Preparation:** Dissolve 5-10 mg of the sample in approximately 0.6 mL of the deuterated solvent in an NMR tube.
- **NMR Acquisition:** Acquire the ¹H and ¹³C NMR spectra.
- **Data Analysis:** Process the spectra (Fourier transform, phase correction, and baseline correction). Integrate the ¹H NMR signals and assign the chemical shifts to the respective protons. Assign the chemical shifts in the ¹³C NMR spectrum. The expected chemical shifts and coupling patterns should be consistent with the structure of **Chroman-4-carboxylic Acid**.

Mass Spectrometry (MS) for Molecular Weight Determination

High-resolution mass spectrometry (HRMS) provides an accurate mass measurement, which can be used to determine the elemental composition of **Chroman-4-carboxylic Acid**.

The Advantage of HRMS: HRMS can measure mass-to-charge ratios to a very high degree of accuracy (typically < 5 ppm), which allows for the unambiguous determination of the elemental formula of a molecule.

Detailed MS Protocol:

Objective: To confirm the molecular weight and determine the elemental composition of **Chroman-4-carboxylic Acid**.

Materials and Reagents:

- **Chroman-4-carboxylic Acid** sample
- Suitable solvent (e.g., methanol or acetonitrile)

Instrumentation:

- Mass spectrometer with a soft ionization source (e.g., ESI or APCI)
- High-resolution mass analyzer (e.g., TOF or Orbitrap)

MS Parameters (ESI-Negative Mode):

Parameter	Recommended Setting
Ionization Mode	Electrospray Ionization (ESI), Negative
Capillary Voltage	-3.5 kV
Cone Voltage	-30 V
Desolvation Gas Flow	600 L/hr
Desolvation Temp	350 °C
Mass Range	50-500 m/z

Procedure:

- **Sample Preparation:** Prepare a dilute solution of the sample (e.g., 10 µg/mL) in the chosen solvent.
- **Infusion:** Infuse the sample directly into the mass spectrometer.
- **Data Acquisition:** Acquire the mass spectrum.

- **Data Analysis:** Determine the accurate mass of the deprotonated molecule $[M-H]^-$. Use the accurate mass to calculate the elemental composition and compare it with the theoretical formula of **Chroman-4-carboxylic Acid** ($C_{10}H_{10}O_3$).

Method Validation and System Suitability

For use in a regulated environment, the analytical methods described must be validated according to ICH guidelines. Key validation parameters include:

- **Specificity:** The ability to assess the analyte unequivocally in the presence of other components.
- **Linearity:** The ability to obtain test results that are directly proportional to the concentration of the analyte.
- **Range:** The interval between the upper and lower concentrations of the analyte that have been demonstrated to be determined with a suitable level of precision, accuracy, and linearity.
- **Accuracy:** The closeness of the test results obtained by the method to the true value.
- **Precision:** The degree of agreement among individual test results when the method is applied repeatedly to multiple samplings of a homogeneous sample.
- **Robustness:** A measure of the method's capacity to remain unaffected by small, but deliberate variations in method parameters.

System suitability tests should be performed before each analytical run to ensure the performance of the analytical system.

Conclusion

The analytical characterization of **Chroman-4-carboxylic Acid** requires a combination of chromatographic and spectroscopic techniques. The protocols provided in this guide offer a robust starting point for developing and implementing methods for the identity, purity, and quantification of this important pharmaceutical intermediate. Adherence to sound scientific

principles and regulatory guidelines is paramount for ensuring the quality and safety of the final drug product.

References

- ICH Harmonised Tripartite Guideline, Q2(R1) Validation of Analytical Procedures: Text and Methodology, International Council for Harmonisation of Technical Requirements for Pharmaceuticals for Human Use. [\[Link\]](#)
- To cite this document: BenchChem. [\[Comprehensive Analytical Strategies for the Characterization of Chroman-4-carboxylic Acid\]](#). BenchChem, [2026]. [\[Online PDF\]](#). Available at: [\[https://www.benchchem.com/product/b3024662/docs#comprehensive-analytical-strategies-for-the-characterization-of-chroman-4-carboxylic-acid\]](https://www.benchchem.com/product/b3024662/docs#comprehensive-analytical-strategies-for-the-characterization-of-chroman-4-carboxylic-acid)

Disclaimer & Data Validity:

The information provided in this document is for Research Use Only (RUO) and is strictly not intended for diagnostic or therapeutic procedures. While BenchChem strives to provide accurate protocols, we make no warranties, express or implied, regarding the fitness of this product for every specific experimental setup.

Technical Support: The protocols provided are for reference purposes. Unsure if this reagent suits your experiment?

Need Industrial/Bulk Grade? [Request Custom Synthesis Quote](#)

BenchChem

Our mission is to be the trusted global source of essential and advanced chemicals, empowering scientists and researchers to drive progress in science and industry.

Contact

Address: 3281 E Guasti Rd

Ontario, CA 91761, United States

Phone: (601) 213-4426

Email: info@benchchem.com

Contact our Ph.D. Support Team for a compatibility check