

Comparative Performance Guide: 4-(Trifluoromethyl)cyclohexanecarboxylic Acid in Lead Optimization

Author: BenchChem Technical Support Team. **Date:** May 2026

Compound of Interest

Compound Name:	4-(Trifluoromethyl)cyclohexanecarboxylic Acid
CAS No.:	95233-30-0
Cat. No.:	B3024382

[Get Quote](#)

Executive Summary: The "Fluorine Effect" in Alicyclic Scaffolds

In modern drug discovery, the cyclohexane ring serves as a critical linker, providing defined vectors for substituent display. While 4-tert-butylcyclohexanecarboxylic acid (4-tBu-CHCA) has long been the gold standard for sterically demanding, conformationally locked scaffolds, **4-(Trifluoromethyl)cyclohexanecarboxylic acid** (4-TFM-CHCA) offers a distinct bioisosteric alternative.

This guide reviews the performance of 4-TFM-CHCA, specifically analyzing its utility in modulating lipophilicity (LogP), metabolic stability (Cl_{int}), and acidity (pKa) compared to its hydrocarbon analogs.

Verdict: 4-TFM-CHCA is the superior choice when the target requires the steric bulk of a tert-butyl group but demands lower oxidative clearance and modulated acidity.

Part 1: Physicochemical Performance Matrix

The substitution of a tert-butyl group with a trifluoromethyl group is not merely a steric swap; it is an electronic modulation. The strong electron-withdrawing nature of the fluorine atoms significantly alters the physicochemical profile of the molecule.

Comparative Data Table

Metric	4-TFM-CHCA (Subject)	4-tBu-CHCA (Comparator)	Impact Analysis
Electronic Effect	Electron-Withdrawing ()	Electron-Donating ()	TFM lowers pKa of the distal acid.
Acidity (pKa)	4.60 ± 0.10	5.03 ± 0.25	TFM analog is more acidic; higher ionization at physiological pH.
Lipophilicity	High (Polar Hydrophobicity)	High (Lipophilic Hydrophobicity)	TFM introduces a dipole moment while maintaining bulk.
Metabolic Stability	High (Blocked C4 position)	Moderate to High	TFM is chemically inert to CYP450 oxidation.
Steric Volume	~42 Å ³	~48 Å ³	TFM is slightly smaller but bioisosteric.
Conformation	Biased Equatorial ()	Locked Equatorial (-Bu)	Both favor trans-diequatorial geometry.

“

Expert Insight: The pKa shift (~0.4 units) is critical. If your lead compound suffers from poor solubility due to high LogD, the increased ionization of the TFM analog at pH 7.4 can improve aqueous solubility without sacrificing the hydrophobic binding interaction required by the target pocket.

Part 2: Metabolic Stability & Pharmacokinetics

One of the primary failure modes for alkyl-rich scaffolds is oxidative metabolism by Cytochrome P450 enzymes (specifically CYP3A4 and CYP2D6).

The Metabolic Block Mechanism

In the tert-butyl analog, the methyl groups are susceptible to hydroxylation (

-oxidation). While the tert-butyl group is relatively stable, the methine proton at the 4-position (if available) or adjacent carbons can be attack points.

The Trifluoromethyl group confers metabolic resistance through two mechanisms:

- **C-F Bond Strength:** The C-F bond (approx. 116 kcal/mol) is significantly stronger than the C-H bond (~99 kcal/mol), rendering the group inert to oxidative attack.
- **Electronic Shielding:** The electron-withdrawing nature of

deactivates the cyclohexane ring toward electrophilic attack by the high-valent iron-oxo species in P450 enzymes.

Visualization: Metabolic Pathway Comparison

The following diagram illustrates the divergence in metabolic fate between the hydrocarbon and fluorinated analogs.

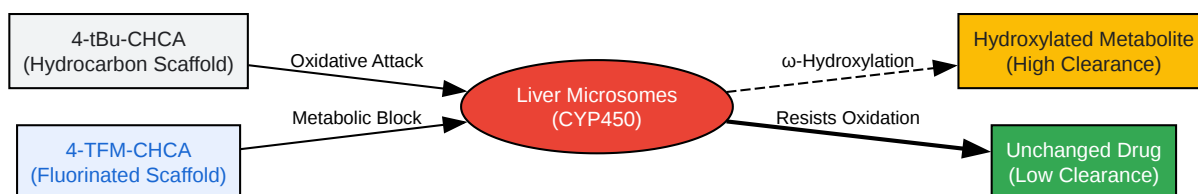

[Click to download full resolution via product page](#)

Figure 1: Metabolic fate divergence.[1] The Trifluoromethyl moiety (blue path) blocks the oxidative hydroxylation pathway common to alkyl groups, leading to improved half-life ().

Part 3: Experimental Protocols

To utilize 4-TFM-CHCA effectively, one must control its stereochemistry. The commercial material often comes as a mixture of cis and trans isomers. For most medicinal chemistry applications, the trans-isomer (diequatorial) is the desired scaffold to extend the pharmacophore linearly.

Protocol 1: Isomer Equilibration and Isolation

Objective: Maximize the yield of the thermodynamically stable trans-isomer.

Reagents:

- Crude **4-(Trifluoromethyl)cyclohexanecarboxylic acid** (cis/trans mix)
- Sodium Ethoxide (NaOEt) or Potassium tert-butoxide (KOtBu)
- Ethanol (EtOH) or THF
- HCl (1M)

Step-by-Step Workflow:

- Dissolution: Dissolve 10.0 g of the crude acid mixture in 100 mL of absolute Ethanol.

- Base Treatment: Add 2.5 equivalents of NaOEt (21% wt in EtOH). The solution will heat up slightly (exothermic).
- Reflux: Heat the mixture to reflux (78°C) for 12–24 hours.
 - Mechanism:^[2]^[3]^[4] The base deprotonates the α -carbon (next to the carboxylate). The resulting enolate is planar. Reprotonation occurs from the less hindered face, driving the equilibrium toward the thermodynamic trans product (where both bulky groups are equatorial).
- Monitoring: Monitor by ¹H-NMR or GC-MS. Look for the shift in the α -proton signal.
 - Trans-isomer:
 - proton appears as a triplet of triplets (tt) with large coupling constants (10–15 Hz) due to axial-axial coupling.
 - Cis-isomer:
 - proton appears as a broad multiplet or quintet with smaller couplings.
- Workup:
 - Cool to room temperature.
 - Concentrate to remove bulk ethanol.
 - Dilute with water (50 mL) and acidify with 1M HCl to pH 2.
 - Extract with Ethyl Acetate (3 x 50 mL).
- Purification: Recrystallize from Hexanes/Ethyl Acetate. The trans-isomer is typically less soluble and crystallizes first.

Protocol 2: Synthesis via Hydrogenation

If starting from 4-(trifluoromethyl)benzoic acid, aromatic hydrogenation is required.

Key Parameter: Catalyst Selection.

- Rh/C (5%) or Ru/C (5%) are superior to Pd/C for reducing electron-deficient aromatic rings.
- Conditions: 50–100 psi

, MeOH, 60°C.
- Note: This method yields a cis-rich mixture initially, requiring the equilibration step described in Protocol 1.

Part 4: Structural Biology & Bioisosterism

When docking 4-TFM-CHCA into a binding pocket previously optimized for a tert-butyl group, consider the "Polar Hydrophobicity" concept.

- Volume: The

group occupies approximately 90% of the volume of a tert-butyl group. It will fit into almost any pocket that accommodates a t-butyl group.
- Dipole: Unlike the non-polar t-butyl, the C-F bonds create a local dipole. If the binding pocket contains backbone amides or polar side chains (Ser, Thr) near the hydrophobic floor, the

group can engage in orthogonal dipolar interactions, potentially increasing potency (

) where a t-butyl group would only offer Van der Waals contact.

Workflow Visualization: Synthesis to Screening

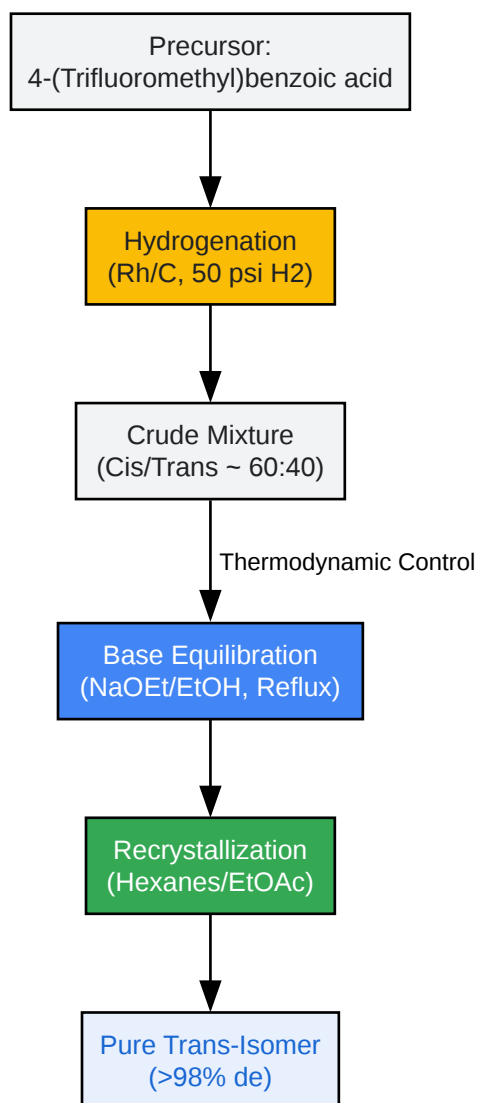

[Click to download full resolution via product page](#)

Figure 2: Synthetic workflow for isolating the bio-active trans-isomer from aromatic precursors. [5][6][7]

References

- Purser, S., et al. "Fluorine in medicinal chemistry." Chemical Society Reviews, 2008.
- Meanwell, N. A. "Fluorine and Fluorinated Motifs in the Design and Application of Bioisosteres for Drug Design." Journal of Medicinal Chemistry, 2018.

- Hagmann, W. K. "The Many Roles for Fluorine in Medicinal Chemistry." *Journal of Medicinal Chemistry*, 2008.
- Linclau, B., et al. "The attractive interaction of the trifluoromethyl group with an amide dipole." *Angewandte Chemie*, 2016.
- Sigma-Aldrich. "**trans-4-(Trifluoromethyl)cyclohexanecarboxylic acid** Product Specification."

Need Custom Synthesis?

BenchChem offers custom synthesis for rare earth carbides and specific isotopic labeling.

Email: info@benchchem.com or [Request Quote Online](#).

Sources

- [1. pubs.acs.org \[pubs.acs.org\]](https://pubs.acs.org)
- [2. Cis vs Trans Conformations Explained: Definition, Examples, Practice & Video Lessons \[pearson.com\]](https://www.pearson.com)
- [3. youtube.com \[youtube.com\]](https://www.youtube.com)
- [4. youtube.com \[youtube.com\]](https://www.youtube.com)
- [5. WO2017134212A1 - Process for the preparation of trans-4-amino-1-cyclohexanecarboxylic acid and its derivatives - Google Patents \[patents.google.com\]](https://patents.google.com)
- [6. TRANS-4-\(TRIFLUOROMETHYL\)CYCLOHEXANECARBOXYLIC ACID | 133261-33-3 \[chemicalbook.com\]](https://www.chemicalbook.com)
- [7. trans-4-\(Phenoxymethyl\)cyclohexanecarboxylic acid - PMC \[pmc.ncbi.nlm.nih.gov\]](https://pubmed.ncbi.nlm.nih.gov)
- To cite this document: BenchChem. [Comparative Performance Guide: 4-(Trifluoromethyl)cyclohexanecarboxylic Acid in Lead Optimization]. BenchChem, [2026]. [Online PDF]. Available at: [\[https://www.benchchem.com/product/b3024382/docs#comparative-performance-guide-4-trifluoromethyl-cyclohexanecarboxylic-acid-in-lead-optimization\]](https://www.benchchem.com/product/b3024382/docs#comparative-performance-guide-4-trifluoromethyl-cyclohexanecarboxylic-acid-in-lead-optimization)

Disclaimer & Data Validity:

The information provided in this document is for Research Use Only (RUO) and is strictly not intended for diagnostic or therapeutic procedures. While BenchChem strives to provide accurate protocols, we make no warranties, express or implied, regarding the fitness of this product for every specific experimental setup.

Technical Support: The protocols provided are for reference purposes. Unsure if this reagent suits your experiment?

Need Industrial/Bulk Grade? [Request Custom Synthesis Quote](#)

BenchChem

Our mission is to be the trusted global source of essential and advanced chemicals, empowering scientists and researchers to drive progress in science and industry.

Contact

Address: 3281 E Guasti Rd
Ontario, CA 91761, United States
Phone: (601) 213-4426
Email: info@benchchem.com

[Contact our Ph.D. Support Team for a compatibility check](#)