

Application Notes and Protocols for the Sonogashira Coupling of Substituted Chloropyrimidines

Author: BenchChem Technical Support Team. **Date:** April 2026

Compound of Interest

| | |
|----------------|-------------------------------------|
| Compound Name: | 2-Chloro-4-ethyl-5-methylpyrimidine |
| CAS No.: | 1233932-32-5 |
| Cat. No.: | B3024486 |

[Get Quote](#)

Introduction: Unlocking the Potential of the Pyrimidine Core

The pyrimidine scaffold is a cornerstone in medicinal chemistry, forming the structural basis of numerous FDA-approved therapeutics, particularly in oncology.^[1] Its prevalence stems from its ability to engage in critical biological interactions, often acting as a bioisostere for purines and participating in hydrogen bonding with kinase hinges. The strategic functionalization of this privileged heterocycle is therefore a paramount objective in modern drug discovery.

The Sonogashira cross-coupling reaction, a powerful method for forging carbon-carbon bonds between sp^2 -hybridized carbons and sp -hybridized carbons, presents a highly effective strategy for introducing alkynyl moieties onto the pyrimidine core.^{[1][2][3]} These alkynyl-substituted pyrimidines serve as versatile intermediates, enabling further molecular elaboration or acting as key pharmacophoric elements themselves. This document provides a detailed technical guide and field-proven protocols for the successful execution of the Sonogashira coupling with

substituted chloropyrimidines, addressing the unique challenges posed by these less reactive, yet readily available, substrates.

Mechanistic Rationale and Strategic Considerations

The Sonogashira reaction traditionally employs a dual catalytic system comprising a palladium complex and a copper(I) salt.^{[2][4][5]} While copper-free variants exist to mitigate side reactions like alkyne homocoupling, the copper-cocatalyzed pathway remains highly efficient and widely utilized.^{[2][6]} Understanding the roles of each component is critical for reaction optimization and troubleshooting.

The Catalytic Duet: Palladium and Copper

The reaction proceeds via two interconnected catalytic cycles:

- **The Palladium Cycle:** The active Pd(0) species undergoes oxidative addition into the C-Cl bond of the pyrimidine ring. This is often the rate-determining step, particularly for less reactive aryl chlorides.^[7]
- **The Copper Cycle:** Concurrently, the copper(I) salt reacts with the terminal alkyne in the presence of a base to form a copper(I) acetylide intermediate.^{[2][4]} This species is more nucleophilic than the parent alkyne.
- **Transmetalation:** The copper acetylide then transfers its alkynyl group to the palladium center, regenerating the copper(I) catalyst.
- **Reductive Elimination:** The newly formed diorganopalladium(II) complex undergoes reductive elimination to yield the desired alkynylpyrimidine product and regenerate the active Pd(0) catalyst, thus completing the cycle.^[4]

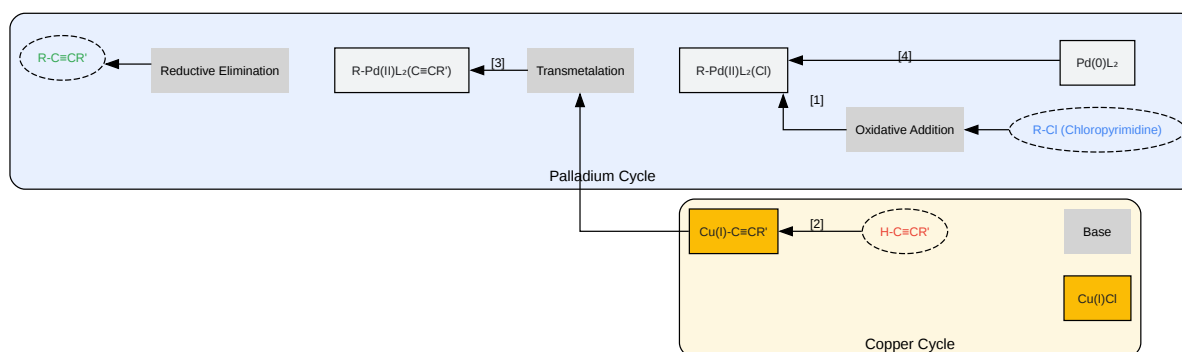

Figure 1: The Copper-Catalyzed Sonogashira Catalytic Cycle

[Click to download full resolution via product page](#)

Figure 1: The Copper-Catalyzed Sonogashira Catalytic Cycle

Key Considerations for Chloropyrimidines

- **Reactivity Hierarchy:** The C-Cl bond is significantly less reactive than C-Br or C-I bonds in palladium-catalyzed couplings.[8] Consequently, more forcing conditions (higher temperatures, more active catalysts) are often required.
- **Regioselectivity:** In polychlorinated pyrimidines, the chlorine atoms exhibit differential reactivity, enabling site-selective functionalization. The general order of reactivity is C4 > C6 > C2.[9] This is governed by the electronic and steric environment of each position; the C4 and C6 positions are more electron-deficient and accessible than the C2 position, which is flanked by two nitrogen atoms.[9][10]
- **Catalyst and Ligand Selection:** For challenging substrates like chloropyrimidines, the choice of the palladium source and its associated ligands is paramount.

- Catalysts: Common precatalysts include $[Pd(PPh_3)_4]$ and $[PdCl_2(PPh_3)_2]$.^{[2][4]} The latter is often more stable and soluble.
- Ligands: Electron-rich and sterically bulky phosphine ligands (e.g., XPhos, SPhos) can accelerate the rate-limiting oxidative addition step and are often beneficial for couplings involving aryl chlorides.^{[6][7]}
- Base and Solvent: An amine base, typically triethylamine (Et_3N) or diisopropylamine (DIPA), is essential to neutralize the HCl generated and to facilitate the deprotonation of the alkyne.^{[2][11]} Often, the amine can serve as both the base and the solvent.^[12] Anhydrous, degassed solvents like tetrahydrofuran (THF) or N,N-dimethylformamide (DMF) are also commonly used.^[9]
- Inert Atmosphere: Sonogashira couplings require an inert atmosphere (Argon or Nitrogen) because the active Pd(0) complexes are oxygen-sensitive, and oxygen can promote the undesirable homocoupling of the terminal alkyne (Glaser coupling).^{[2][8]}

Optimized Protocol: Sonogashira Coupling of 2,4-Dichloropyrimidine

This protocol provides a robust starting point for the regioselective Sonogashira coupling at the more reactive C4 position of 2,4-dichloropyrimidine. Optimization may be required for different substituted chloropyrimidines or terminal alkynes.

Materials and Reagents

- Substrate: 2,4-Dichloropyrimidine (1.0 equiv.)
- Alkyne: Terminal Alkyne (e.g., Phenylacetylene, 1.1-1.2 equiv.)
- Palladium Catalyst: Bis(triphenylphosphine)palladium(II) dichloride $[PdCl_2(PPh_3)_2]$ (1-5 mol%)
- Copper Co-catalyst: Copper(I) iodide $[CuI]$ (2-10 mol%)
- Base: Triethylamine (Et_3N), distilled and degassed

- Solvent: Anhydrous, degassed Tetrahydrofuran (THF)
- Other: Anhydrous sodium sulfate (Na_2SO_4), Celite®, Silica gel for chromatography, Deuterated solvent for NMR analysis, Solvents for chromatography (e.g., Hexanes, Ethyl Acetate).

Experimental Workflow

Figure 2: Step-by-Step Experimental Workflow

Step-by-Step Procedure

- Preparation: To a flame-dried Schlenk flask equipped with a magnetic stir bar, add 2,4-dichloropyrimidine (1.0 mmol, 1.0 equiv.), $[\text{PdCl}_2(\text{PPh}_3)_2]$ (0.03 mmol, 3 mol%), and CuI (0.06 mmol, 6 mol%).
- Inerting: Seal the flask with a septum, and evacuate and backfill with dry argon or nitrogen. Repeat this cycle three times to ensure an inert atmosphere.[8]
- Solvent and Reagent Addition: Add anhydrous, degassed THF (~10 mL) followed by degassed triethylamine (3.0 mmol, 3.0 equiv.) via syringe. Stir the resulting suspension for 5-10 minutes at room temperature.
- Alkyne Addition: Add the terminal alkyne (1.1 mmol, 1.1 equiv.) dropwise via syringe.
- Reaction: Heat the reaction mixture to 50-70 °C. Monitor the progress of the reaction by Thin Layer Chromatography (TLC) or Liquid Chromatography-Mass Spectrometry (LC-MS) until the starting material is consumed (typically 4-24 hours).
- Work-up: Upon completion, cool the reaction mixture to room temperature. Dilute with ethyl acetate and filter the mixture through a pad of Celite® to remove the catalyst residues, washing the pad with additional ethyl acetate.
- Extraction: Transfer the filtrate to a separatory funnel and wash sequentially with water and brine. Dry the organic layer over anhydrous sodium sulfate (Na_2SO_4), filter, and concentrate under reduced pressure.
- Purification: Purify the crude residue by flash column chromatography on silica gel using an appropriate eluent system (e.g., a gradient of ethyl acetate in hexanes) to afford the pure 2-

chloro-4-alkynylpyrimidine product.

Data Summary: Representative Reaction Conditions

The conditions outlined below serve as a general guide. Yields are highly dependent on the specific substrates used.

| Chloropyrimidine Substrate | Alkyne Substrate | Pd Catalyst (mol%) | CuI (mol%) | Base (equiv.) | Solvent | Temp (°C) | Typical Yield Range |
|-----------------------------------|-------------------------|--|------------|-------------------------------------|---------|-----------|----------------------|
| 2,4,6-Trichloropyrimidine | Phenylacetylene | PdCl ₂ (PPh ₃) ₂ (3) | 6 | Et ₃ N (3) | THF | 60-70 | 70-90% (at C4) |
| 2,4-Dichloropyrimidine | 1-Heptyne | Pd(PPh ₃) ₄ (5) | 10 | Et ₃ N (2) | DMF | 80 | 65-85% (at C4) |
| 5-Bromo-2-chloropyrimidine | Trimethylsilylacetylene | Pd(PPh ₃) ₄ (5) | 10 | DIPA (2) | THF | RT-50 | >90% (at C5-Br) |
| 4-Chloro-2-(methylthio)pyrimidine | 4-Ethynylanisole | Pd ₂ (dba) ₃ /XPhos (2/4) | — | CS ₂ CO ₃ (2) | Dioxane | 100 | 60-80% (Copper-free) |

Troubleshooting and Field-Proven Insights

- Problem: Reaction is sluggish or fails to initiate.
 - Insight: The quality of the copper(I) iodide and the amine base is critical. CuI should be off-white or light tan; dark green or brown CuI is oxidized and inactive. The amine base

should be distilled and stored over KOH to remove water and amine oxides, which can poison the catalyst.[12] Filtering the amine through a plug of alumina just before use can be effective.[12]

- Problem: Significant formation of a dark precipitate (Palladium black).
 - Insight: This indicates catalyst decomposition. Ensure the reaction is rigorously deoxygenated. If the problem persists, consider a more robust ligand system (e.g., using a precatalyst like Pd₂(dba)₃ with a bulky, electron-rich phosphine ligand).[6] Anecdotal evidence suggests that THF can sometimes promote the formation of Pd black; switching the solvent to DMF or using the amine as the solvent may help.[12]
- Problem: Formation of alkyne homocoupling (Glaser) product.
 - Insight: This side reaction is promoted by oxygen and excess copper. Ensure strict anaerobic conditions. If it remains a problem, a copper-free protocol is the best solution.[6] Copper-free conditions often require a stronger base (e.g., Cs₂CO₃, K₃PO₄) and may benefit from more specialized palladium/ligand systems.[6][13]
- Problem: Difficulty coupling electron-rich or sterically hindered chloropyrimidines.
 - Insight: These substrates are particularly challenging. Increase the reaction temperature (microwave irradiation can be highly effective for accelerating these reactions), and employ a more active catalyst system, such as one using a bulky N-heterocyclic carbene (NHC) or phosphine ligand.[7][14][15]

Conclusion

The Sonogashira coupling of substituted chloropyrimidines is a robust and highly valuable transformation for the synthesis of complex molecules in drug discovery and materials science. While the lower reactivity of the C-Cl bond presents challenges, these can be readily overcome through the careful selection of catalysts, ligands, and reaction conditions. By understanding the underlying mechanism and the key parameters governing reactivity and selectivity, researchers can effectively leverage this protocol to unlock novel chemical space and accelerate the development of innovative molecular entities.

References

- Wikipedia. Sonogashira coupling. [\[Link\]](#)
- Pearson+. What is the role of copper in the Sonogashira coupling reaction? | Study Prep. [\[Link\]](#)
- Chemistry LibreTexts. Sonogashira Coupling. [\[Link\]](#)
- MDPI. Palladium and Copper Catalyzed Sonogashira cross Coupling an Excellent Methodology for C-C Bond Formation over 17 Years: A Review. [\[Link\]](#)
- Sussex Drug Discovery Centre. Guidelines for Sonogashira cross-coupling reactions. [\[Link\]](#)
- RSC Publishing. Copper-catalyzed Sonogashira reactions: advances and perspectives since 2014. [\[Link\]](#)
- ACS Publications. Two Competing Mechanisms for the Copper-Free Sonogashira Cross-Coupling Reaction | Organometallics. [\[Link\]](#)
- Organic Chemistry Portal. Sonogashira Coupling. [\[Link\]](#)
- ResearchGate. Coupling reaction of organoboronic acids with chloropyrimidines and trichlorotriazine. [\[Link\]](#)
- PMC. Protocol for Sonogashira coupling of alkynes and aryl halides via nickel catalysis. [\[Link\]](#)
- Universiteit Leiden. Catalyst-controlled regioselective Sonogashira coupling of 9-substituted-6-chloro-2,8-diiodopurines. [\[Link\]](#)
- Royal Society of Chemistry. Sonogashira Coupling | Synthetic Methods in Drug Discovery: Volume 1. [\[Link\]](#)
- ResearchGate. (PDF) Recent Advances in Sonogashira Reactions. [\[Link\]](#)
- ACS Publications. Two Competing Mechanisms for the Copper-Free Sonogashira Cross-Coupling Reaction. [\[Link\]](#)

- KAUST Repository. Optimization of an Efficient and Sustainable Sonogashira Cross-Coupling Protocol. [\[Link\]](#)
- Beilstein Journals. Recent developments and trends in the iron- and cobalt-catalyzed Sonogashira reactions. [\[Link\]](#)
- Semantic Scholar. Microwave-Assisted Regioselective Suzuki Coupling of 2,4-Dichloropyrimidines with Aryl and Heteroaryl Boronic Acids. [\[Link\]](#)
- Reddit. Struggling to make a sonogashira coupling reaction happen : r/Chempros. [\[Link\]](#)
- RSC Publishing. Catalyst-controlled regioselective Sonogashira coupling of 9-substituted-6-chloro-2,8-diiodopurines - Organic Chemistry Frontiers. [\[Link\]](#)
- ACS Publications. Copper-Catalyzed Direct Syntheses of Phenoxyrimidines from Chloropyrimidines and Arylboronic Acids: A Cascade Avenue and Unconventional Substrate Pairs. [\[Link\]](#)
- Beilstein-Journals. Recent developments and trends in the iron- and cobalt-catalyzed Sonogashira reactions. [\[Link\]](#)
- ResearchGate. Microwave-Assisted Synthesis of Aminopyrimidines | Request PDF. [\[Link\]](#)
- Preprints.org. Copper-Free Sonogashira Cross-Coupling of Aryl Chlorides with (Hetero)arylacetylenes in the Presence of Ppm Molar Loadings of $\{[Pd(OH)Cl(NHC)]_2\}$ Complexes. Hydrogen Chloride as a Coupling Product. Co-catalytic Effect of Water. [\[Link\]](#)
- MDPI. Synthesis of Alkynyl Ketones by Sonogashira Cross-Coupling of Acyl Chlorides with Terminal Alkynes Mediated by Palladium Catalysts Deposited over Donor-Functionalized Silica Gel. [\[Link\]](#)
- J&K Scientific LLC. Sonogashira Cross-Coupling. [\[Link\]](#)
- Semantic Scholar. Recent Applications of the Sonogashira Reaction in the Synthesis of Drugs and Their Derivatives: A Review. [\[Link\]](#)
- ResearchGate. (PDF) Microwave-Assisted Suzuki-Miyaura and Sonogashira. [\[Link\]](#)

- ResearchGate. Sonogashira cross-coupling of 3a–c with terminal alkynes to afford... [[Link](#)]
- Organic Chemistry Portal. Rapid Homogeneous-Phase Sonogashira Coupling Reactions Using Controlled Microwave Heating. [[Link](#)]
- ResearchGate. Recent Applications of the Sonogashira Reaction in the Synthesis of Drugs and Their Derivatives: A Review | Request PDF. [[Link](#)]
- Figshare. Process Research and Development of a Dihydropyrimidine Dehydrogenase Inactivator: Large-Scale Preparation of Eniluracil Using a Sonogashira Coupling. [[Link](#)]
- ResearchGate. Synthesis of Aryl-Substituted Pyrimidines by Site-Selective Suzuki–Miyura Cross-Coupling Reactions of 2,4,5,6-Tetrachloropyrimidine. [[Link](#)]
- RSC Publishing. Recent advances in Sonogashira reactions - Chemical Society Reviews. [[Link](#)]
- ResearchGate. Sonogashira cross-coupling reaction in 4-chloro-2-trichloromethylquinazoline series is possible despite a side dimerization reaction | Request PDF. [[Link](#)]

Need Custom Synthesis?

BenchChem offers custom synthesis for rare earth carbides and specific isotopic labeling.

Email: info@benchchem.com or [Request Quote Online](#).

Sources

- [1. pdf.benchchem.com](https://pdf.benchchem.com) [pdf.benchchem.com]
- [2. Sonogashira coupling - Wikipedia](https://en.wikipedia.org) [en.wikipedia.org]
- [3. mdpi.com](https://mdpi.com) [mdpi.com]
- [4. chem.libretexts.org](https://chem.libretexts.org) [chem.libretexts.org]
- [5. researchgate.net](https://researchgate.net) [researchgate.net]
- [6. pdf.benchchem.com](https://pdf.benchchem.com) [pdf.benchchem.com]
- [7. books.rsc.org](https://books.rsc.org) [books.rsc.org]

- [8. pdf.benchchem.com \[pdf.benchchem.com\]](https://pdf.benchchem.com)
- [9. pdf.benchchem.com \[pdf.benchchem.com\]](https://pdf.benchchem.com)
- [10. researchgate.net \[researchgate.net\]](https://researchgate.net)
- [11. jk-sci.com \[jk-sci.com\]](https://jk-sci.com)
- [12. reddit.com \[reddit.com\]](https://reddit.com)
- [13. Sonogashira Coupling \[organic-chemistry.org\]](https://organic-chemistry.org)
- [14. Rapid Homogeneous-Phase Sonogashira Coupling Reactions Using Controlled Microwave Heating \[organic-chemistry.org\]](https://organic-chemistry.org)
- [15. pdf.benchchem.com \[pdf.benchchem.com\]](https://pdf.benchchem.com)
- To cite this document: BenchChem. [Application Notes and Protocols for the Sonogashira Coupling of Substituted Chloropyrimidines]. BenchChem, [2026]. [Online PDF]. Available at: [\[https://www.benchchem.com/product/b3024486/docs#application-notes-and-protocols-for-the-sonogashira-coupling-of-substituted-chloropyrimidines\]](https://www.benchchem.com/product/b3024486/docs#application-notes-and-protocols-for-the-sonogashira-coupling-of-substituted-chloropyrimidines)

Disclaimer & Data Validity:

The information provided in this document is for Research Use Only (RUO) and is strictly not intended for diagnostic or therapeutic procedures. While BenchChem strives to provide accurate protocols, we make no warranties, express or implied, regarding the fitness of this product for every specific experimental setup.

Technical Support: The protocols provided are for reference purposes. Unsure if this reagent suits your experiment?

Need Industrial/Bulk Grade? [Request Custom Synthesis Quote](#)

BenchChem

Our mission is to be the trusted global source of essential and advanced chemicals, empowering scientists and researchers to drive progress in science and industry.

Contact

Address: 3281 E Guasti Rd

Ontario, CA 91761, United States

Phone: (601) 213-4426

Email: info@benchchem.com

Contact our Ph.D. Support Team for a compatibility check