

Application Note: One-Pot Synthesis Techniques for Substituted Dihydrochalcones

Author: BenchChem Technical Support Team. **Date:** April 2026

Compound of Interest

Compound Name: 3'-Cyano-3-(3,5-dimethylphenyl)propiophenone

CAS No.: 898780-26-2

Cat. No.: B3023884

[Get Quote](#)

Executive Summary

Dihydrochalcones (DHCs) represent a critical scaffold in medicinal chemistry and food science, serving as potent antioxidants (e.g., Phloretin), non-caloric sweeteners (e.g., Neohesperidin DC), and antidiabetic agents. Traditional synthesis involves a laborious two-step process: Claisen-Schmidt condensation to form a chalcone, followed by isolation, purification, and a separate hydrogenation step.

This guide details one-pot (telescoped) protocols that eliminate intermediate isolation, significantly reducing solvent waste and processing time. We focus on two primary methodologies:

- **Sequential Reductive Condensation:** A telescoped aldol condensation followed by in-situ Catalytic Transfer Hydrogenation (CTH).
- **Direct Friedel-Crafts Alkylation:** A convergent approach using acid-catalyzed coupling.

Mechanistic Strategies & Pathway Logic

To achieve a "one-pot" outcome, we must reconcile the conflicting conditions of the two required transformations: the base-mediated aldol condensation and the typically neutral/acidic hydrogenation.

Reaction Pathways Overview

The following diagram illustrates the two strategic entry points for DHC synthesis.

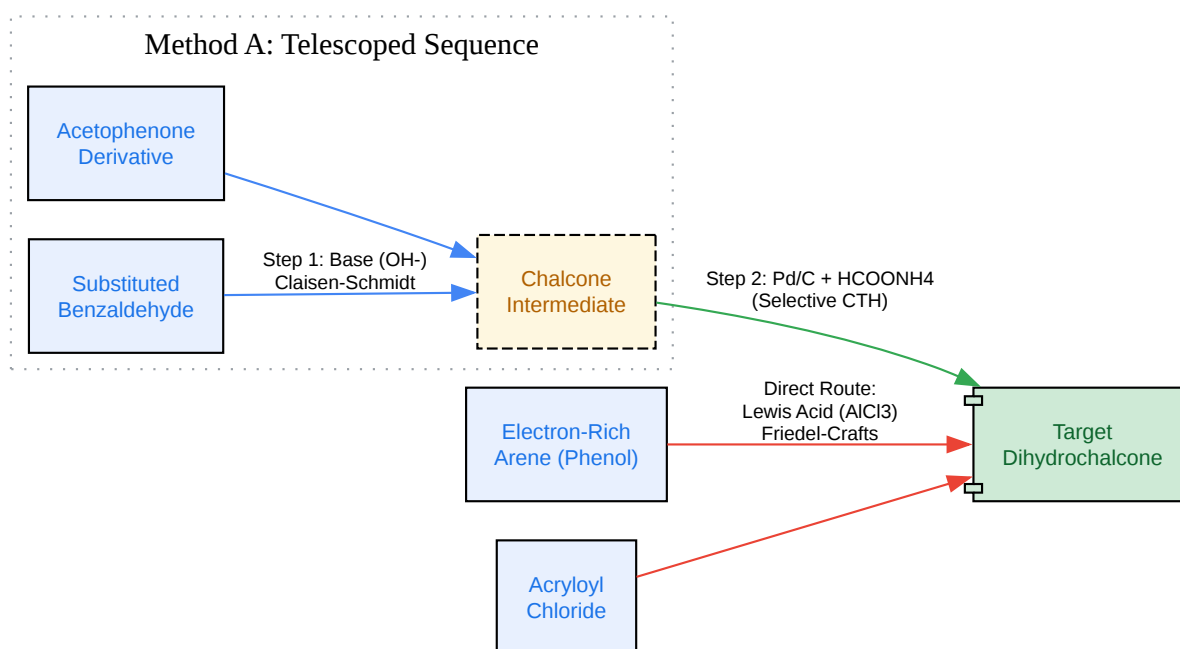

[Click to download full resolution via product page](#)

Figure 1: Comparison of Telescoped Reductive Condensation (Method A) and Direct Friedel-Crafts (Method B) pathways.

Protocol A: Telescoped Reductive Condensation (The "Workhorse" Method)

This method is preferred for its versatility and mild conditions. It combines base-catalyzed condensation with Catalytic Transfer Hydrogenation (CTH) using ammonium formate. CTH is superior to H₂ gas balloons for one-pot protocols because it allows precise stoichiometric control, minimizing the risk of over-reducing the ketone to an alcohol [1, 2].

Critical Parameters

- Solvent System: Ethanol/Water (Eco-friendly, supports both steps).
- Catalyst: 10% Pd/C.
- Hydrogen Source: Ammonium Formate (Solid, easy to handle).
- Selectivity Control: The rate of C=C reduction is significantly faster than C=O reduction under mild CTH conditions. Stopping the reaction immediately after alkene consumption is crucial.

Step-by-Step Protocol

Materials:

- Substituted Benzaldehyde (1.0 equiv)[1]
- Substituted Acetophenone (1.0 equiv)[1]
- NaOH (2.0 equiv, 40% aq. solution)
- Ethanol (10 mL/mmol)
- Ammonium Formate (2.5 - 3.0 equiv)
- 10% Pd/C (5-10 wt% of substrate mass)

Workflow:

- Condensation Phase:
 - Dissolve aldehyde and acetophenone in Ethanol in a round-bottom flask.
 - Add NaOH solution dropwise at room temperature (RT).

- Observation: Solution typically turns yellow/orange, indicating chalcone formation.
- Stir at RT for 2–4 hours. Monitor by TLC (Hexane:EtOAc 4:1) until starting materials disappear.
- Transition (The "Telescope"):
 - Crucial Step: Do not isolate the solid chalcone.
 - If the mixture is a thick slurry, add a minimal amount of Ethanol to facilitate stirring.
 - Optional: Some protocols suggest neutralizing with dilute HCl, but ammonium formate works effectively in slightly basic/neutral media. For sensitive substrates, adjust pH to ~7-8 with dilute HCl.
- Reduction Phase:
 - Add 10% Pd/C carefully to the reaction mixture.
 - Add Ammonium Formate in a single portion.
 - Reflux the mixture (approx. 70–80°C) for 30–60 minutes.
 - Monitoring: The intense yellow color of the chalcone will fade to colorless or pale yellow. Stop heating immediately upon decolorization to prevent ketone reduction [2].
- Workup:
 - Filter hot through a Celite pad to remove Pd/C. Wash the pad with hot ethanol.
 - Concentrate the filtrate under reduced pressure.
 - Add water and extract with Ethyl Acetate (3x).
 - Wash combined organics with brine, dry over Na₂SO₄, and concentrate.
 - Recrystallize from Ethanol/Water if necessary.[1]

Data Summary Table: Typical Yields (Method A)

Substrate (Aldehyde)	Substrate (Ketone)	Time (Condensation)	Time (Reduction)	Yield (Isolated)
Benzaldehyde	Acetophenone	2 h	30 min	92%
4-Methoxybenzaldehyde	4-Hydroxyacetophenone	4 h	45 min	85%
3-Nitrobenzaldehyde	Acetophenone	1.5 h	20 min	88%*

*Note: Nitro groups may be reduced to amines under these conditions. Use Method B for nitro-containing substrates.

Protocol B: Direct Friedel-Crafts Alkylation

This method is ideal for electron-rich phenolic substrates (e.g., synthesis of Phloretin analogues). It utilizes a Lewis acid to drive the reaction between a dihydrocinnamic acid (or acryloyl chloride) and a phenol [3].

Mechanism & Logic

Unlike Method A, this forms the C-C bond after the saturation level is established (if using dihydrocinnamic acid) or uses a tandem alkylation mechanism. The key here is the "Tandem Friedel-Crafts Acylation-Alkylation" if starting from acryloyl chloride.

Step-by-Step Protocol

Materials:

- Substituted Phenol (1.0 equiv)
- 3-Chloropropionyl chloride or Acryloyl chloride (1.2 equiv)
- Lewis Acid: AlCl_3 (3.0 equiv) or $\text{BF}_3 \cdot \text{OEt}_2$

- Solvent: Dichloromethane (DCM) or Nitromethane (anhydrous)

Workflow:

- Setup:
 - Flame-dry a two-neck flask and purge with Argon/Nitrogen.
 - Add AlCl_3 and DCM; cool to 0°C .
- Acylation/Alkylation:
 - Add the Phenol and Acryloyl chloride sequentially.
 - Allow the mixture to warm to RT and stir for 6–12 hours.
 - Mechanism:^{[1][2][3][4]} The reaction proceeds via an initial esterification (in some cases) followed by Fries rearrangement or direct ring acylation.
- Quenching:
 - Pour the reaction mixture carefully onto crushed ice/HCl.
 - Safety: Exothermic reaction with HCl gas evolution.
- Purification:
 - Extract with DCM, wash with NaHCO_3 (to remove unreacted acids).
 - Purify via column chromatography (DHCs from this method often require silica gel purification due to regioisomers).

Experimental Workflow Visualization

The following diagram details the decision-making process and workflow for the Telescoped Method (Protocol A), which is the most broadly applicable for general research.

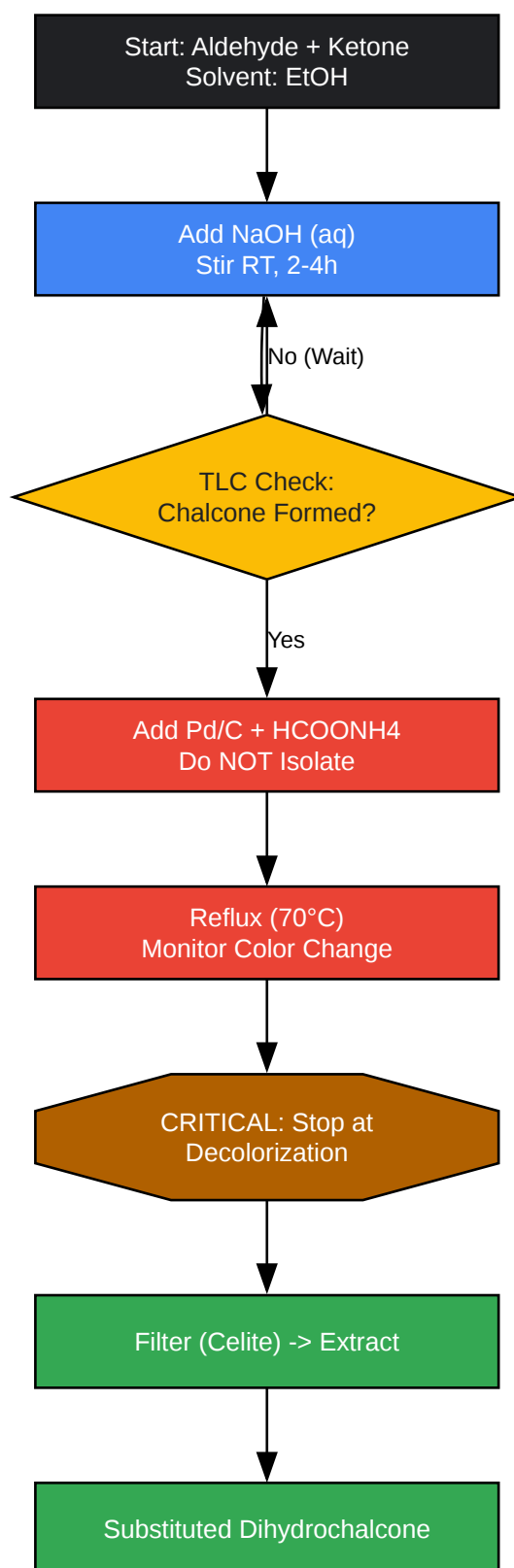

[Click to download full resolution via product page](#)

Figure 2: Operational workflow for the telescoped synthesis of dihydrochalcones.

Troubleshooting & Optimization (Expert Insights)

Issue	Probable Cause	Corrective Action
Over-reduction (Alcohol formation)	Reaction time too long or excess reductant.	Stop reaction immediately when yellow color fades. Reduce Ammonium Formate to 2.0 equiv.
Incomplete Condensation	Steric hindrance on aldehyde or weak base.	Increase temperature of Step 1 to 40°C or use KOH instead of NaOH.
Dimerization/Side Products	High concentration leading to Michael addition.	Dilute the reaction mixture before adding the reducing agent.
Catalyst Poisoning	Sulfur or amine groups in substrate.	Use higher Pd loading (10-20%) or switch to Raney Nickel (requires H ₂ pressure).

References

- Ahmed, N., & van Lier, J. E. (2006). Pd-C/ammonium formate: a selective catalyst for the hydrogenation of chalcones to dihydrochalcones.[5] *Journal of Chemical Research*, 2006(5), 371-373.
- Andrade, C. K. Z., & Silva, W. A. (2006). One-Step Reduction of Chalcones to Saturated Alcohols by Ammonium Formate/Palladium on Carbon: A Versatile Method.[6][7] *Letters in Organic Chemistry*, 3(1), 39-41. (Note: Discusses conditions leading to alcohols, establishing the boundary for DHC selectivity).
- Wang, D., et al. (2012). Facile synthesis of dihydrochalcones via the AlCl₃-promoted tandem Friedel–Crafts acylation and alkylation. *Tetrahedron Letters*, 53(15), 1978-1982.
- Gallagher, K. M., et al. (2009). Synthesis and Hydrogenation of Disubstituted Chalcones: A Guided-Inquiry Organic Chemistry Project. *Journal of Chemical Education*, 86(2).

Need Custom Synthesis?

BenchChem offers custom synthesis for rare earth carbides and specific isotopic labeling.

Email: info@benchchem.com or [Request Quote Online](#).

Sources

- [1. chemrevlett.com](http://chemrevlett.com) [chemrevlett.com]
- [2. uomustansiriyah.edu.iq](http://uomustansiriyah.edu.iq) [uomustansiriyah.edu.iq]
- [3. researchgate.net](http://researchgate.net) [researchgate.net]
- [4. par.nsf.gov](http://par.nsf.gov) [par.nsf.gov]
- [5. researchgate.net](http://researchgate.net) [researchgate.net]
- [6. researchgate.net](http://researchgate.net) [researchgate.net]
- [7. discovery.researcher.life](http://discovery.researcher.life) [discovery.researcher.life]
- To cite this document: BenchChem. [Application Note: One-Pot Synthesis Techniques for Substituted Dihydrochalcones]. BenchChem, [2026]. [Online PDF]. Available at: [<https://www.benchchem.com/product/b3023884/docs#application-note-one-pot-synthesis-techniques-for-substituted-dihydrochalcones>]

Disclaimer & Data Validity:

The information provided in this document is for Research Use Only (RUO) and is strictly not intended for diagnostic or therapeutic procedures. While BenchChem strives to provide accurate protocols, we make no warranties, express or implied, regarding the fitness of this product for every specific experimental setup.

Technical Support: The protocols provided are for reference purposes. Unsure if this reagent suits your experiment?

Need Industrial/Bulk Grade? [Request Custom Synthesis Quote](#)

BenchChem

Our mission is to be the trusted global source of essential and advanced chemicals, empowering scientists and researchers to drive progress in science and industry.

Contact

Address: 3281 E Guasti Rd

Ontario, CA 91761, United States

Phone: (601) 213-4426

Email: info@benchchem.com

[Contact our Ph.D. Support Team for a compatibility check](#)