

Application Note: Microwave-Assisted Synthesis of N-Heterocyclic Acetamides

Author: BenchChem Technical Support Team. **Date:** April 2026

Compound of Interest

Compound Name: Acetamide, N-3-dibenzofuranyl-

CAS No.: 5834-25-3

Cat. No.: B3023428

[Get Quote](#)

Abstract

N-heterocyclic acetamides are privileged scaffolds in modern drug discovery, appearing in over a quarter of all known pharmaceuticals.[1] Their synthesis, however, can be challenging, often requiring harsh conditions, long reaction times, and complex purification procedures. This application note provides a comprehensive guide to the use of Microwave-Assisted Organic Synthesis (MAOS) for the rapid, efficient, and clean preparation of N-heterocyclic acetamides. We will explore the fundamental principles of microwave heating, present detailed, field-tested protocols for direct amidation, and offer expert insights into reaction optimization and troubleshooting. This guide is intended for researchers, chemists, and drug development professionals seeking to leverage this powerful green chemistry technique to accelerate their discovery workflows.[2][3]

Introduction: The Microwave Advantage in Amide Bond Formation

The amide bond is a cornerstone of medicinal chemistry, yet its formation is not always straightforward. Traditional methods often rely on stoichiometric activating agents, which

generate significant waste, or require high temperatures and prolonged heating, leading to side-product formation and decomposition of sensitive substrates.[1][4]

Microwave-Assisted Organic Synthesis (MAOS) has emerged as a transformative technology that directly addresses these challenges.[3] Unlike conventional conductive heating, which relies on slow, inefficient heat transfer from an external source, microwave irradiation provides rapid and uniform "volumetric" heating.[5][6] This is achieved through the direct interaction of the electromagnetic field with polar molecules in the reaction mixture.

Core Mechanisms of Microwave Heating:

- **Dipolar Polarization:** Polar molecules, such as the solvents and reactants in an amidation reaction, continuously attempt to align their dipoles with the rapidly oscillating electric field of the microwave. This constant reorientation generates friction, leading to rapid and efficient heating of the bulk material.[7]
- **Ionic Conduction:** If charged particles (ions) are present, they will migrate through the solution under the influence of the oscillating electric field. Collisions with other molecules generate heat, contributing to the overall temperature increase.[7]

This direct energy transfer mechanism results in remarkable reaction rate accelerations, often reducing reaction times from many hours to mere minutes.[5][8][9] The result is not only a significant increase in throughput but also often leads to higher product yields and improved purity profiles by minimizing the time available for side reactions to occur.[2][8]

General Protocol: Microwave-Assisted Acetylation of N-Heterocycles

This section details a robust, general protocol for the direct amidation of a primary or secondary amine-containing N-heterocycle with a carboxylic acid under microwave conditions. This procedure is designed to be a starting point and can be optimized for specific substrates.

Essential Equipment and Reagents

- **Microwave Reactor:** A dedicated single-mode microwave synthesizer (e.g., CEM Discover®, Biotage® Initiator+) is required for controlled and safe operation.[10][11][12] Domestic microwave ovens should never be used for chemical synthesis.

- Reaction Vessels: Use only manufacturer-approved microwave process vials (e.g., 2-5 mL or 10 mL) capable of withstanding high pressures and temperatures.[10][13]
- Stir Bars: A magnetic stir bar appropriate for the vial size is crucial for ensuring uniform heat distribution.[14]
- Reagents:
 - N-Heterocyclic Amine (1.0 equiv)
 - Carboxylic Acid (e.g., Acetic Acid, 1.1 - 2.0 equiv)
 - High-boiling point, microwave-absorbent solvent (e.g., DMF, DMSO, NMP, or Acetonitrile)
 - (Optional) Catalyst: For less reactive partners, a catalyst such as ceric ammonium nitrate (CAN) may be beneficial.[4][15]
 - (Optional) Dehydrating agent or coupling reagent.

Step-by-Step Experimental Procedure

- Vial Preparation: Place a suitable magnetic stir bar into a clean, dry microwave reaction vial.
- Reagent Addition: To the vial, add the N-heterocyclic amine (e.g., 0.5 mmol, 1.0 equiv).
- Solvent & Acid Addition: Add the chosen solvent (e.g., 2.0 mL of DMF). Ensure all solid material is wetted by the solvent.[13] Add the carboxylic acid (e.g., 0.6 mmol, 1.2 equiv). If using a catalyst, it should be added at this stage.
- Sealing: Securely seal the vial with a new, appropriate cap or septum. An improper seal can lead to solvent loss and pressure failure.[10]
- Microwave Reactor Setup:
 - Place the sealed vial into the microwave cavity.
 - Program the reaction parameters. A typical starting point for amidation is:
 - Temperature: 150 °C

- Time: 10-20 minutes
 - Power: Dynamic (instrument automatically adjusts power to maintain temperature)
 - Stirring: High
 - Pre-stirring: 10 seconds[10]
- Initiate Synthesis: Start the microwave program. The instrument will monitor temperature and pressure in real-time.
 - Cooling: After the irradiation period, the instrument will automatically cool the vial with a jet of compressed air to a safe handling temperature (typically < 50 °C).[10]
 - Work-up & Analysis: Once cooled, carefully uncap the vial in a fume hood. The reaction mixture can be analyzed by TLC or LC-MS to determine conversion. The product can then be isolated using standard purification techniques (e.g., extraction, crystallization, or column chromatography).

Workflow Visualization

The following diagram illustrates the general workflow for this protocol.

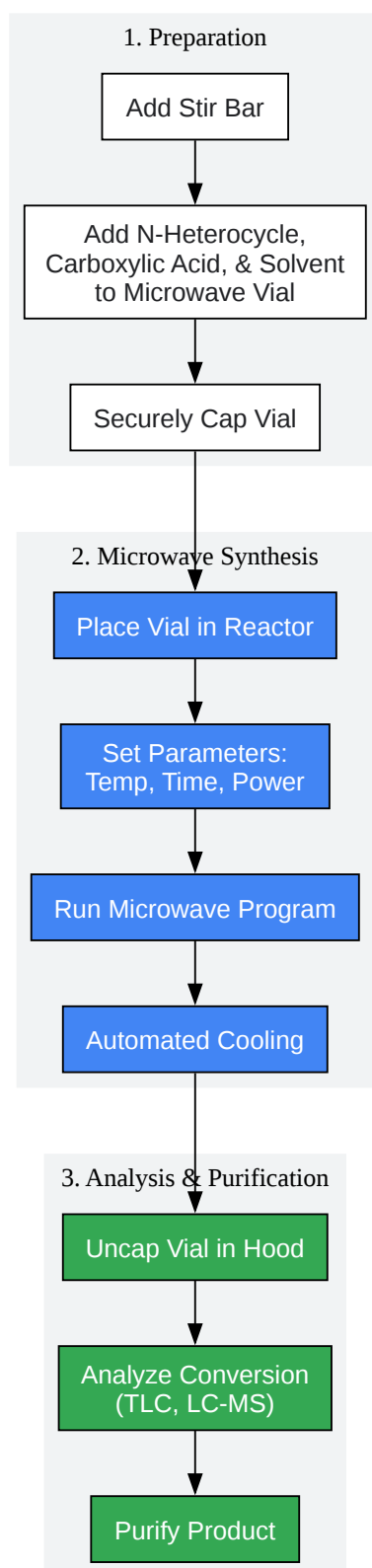

[Click to download full resolution via product page](#)

Caption: General workflow for microwave-assisted N-acetamide synthesis.

Case Study: Comparative Synthesis

To illustrate the profound impact of MAOS, consider the synthesis of various aminopyridine, pyrrolidine, and piperidine acetamides. A study demonstrated that these compounds could be prepared in minutes with good yields under microwave irradiation, whereas conventional heating required 2-3 hours to achieve moderate yields.[16]

Compound Type	Conventional Method (70°C)	Microwave Method (65-70°C)
Reaction Time	2–3 hours	3–5 minutes
Yield	~60% (Moderate)	75–85% (Good to Excellent)
Solvent	Acetonitrile	Acetonitrile
Base	Triethylamine	Triethylamine

Data synthesized from literature reports for illustrative purposes.[16]

This dramatic reduction in reaction time—by a factor of over 30—while simultaneously increasing the yield, highlights the primary driver for adopting MAOS in a drug discovery setting: efficiency and speed.[8][16]

Optimization and Troubleshooting

While the general protocol is robust, optimization is often necessary for novel or challenging substrates.

- **Solvent Choice:** The solvent must be polar enough to absorb microwave energy efficiently. High-boiling point solvents like DMF, DMSO, and NMP are excellent choices as they allow for high reaction temperatures to be reached. For lower temperature reactions, solvents like acetonitrile or ethanol can be effective.
- **Temperature Screening:** If the initial reaction at 150 °C gives low conversion, incrementally increase the temperature (e.g., to 170 °C or 190 °C). Conversely, if side products are observed, a lower temperature may be beneficial. Modern reactors allow for precise temperature control, which is a key advantage.[5]

- **Time:** If conversion is incomplete after 15 minutes, the reaction time can be extended. However, one of the primary goals of MAOS is speed; if a reaction requires more than 60 minutes, a change in solvent, temperature, or the addition of a catalyst should be considered.
- **Catalysis:** For difficult couplings between electron-poor amines and electron-rich acids (or vice-versa), direct amidation may be slow. The use of a catalyst, such as a Lewis acid, can facilitate the reaction.^{[4][15]} Solvent-free conditions, using a solid support or a neat mixture of reactants, can also be highly effective and align with green chemistry principles.^{[17][18]}
- **Safety and Pressure:** Always operate within the pressure and temperature limits of the reaction vessel. If a reaction is known to produce gaseous byproducts, use a system with pressure management technology, such as CEM's ActiVent®, to prevent over-pressurization.^[11] Never exceed the recommended maximum fill volume for the vial.^[14]

Conclusion

Microwave-assisted synthesis represents a paradigm shift in the preparation of N-heterocyclic acetamides. By leveraging direct, efficient energy transfer, MAOS dramatically accelerates reaction rates, reduces synthesis times from hours to minutes, and often improves yields and product purity.^{[2][3][9]} This technology empowers researchers to rapidly generate libraries of target compounds, accelerating the pace of drug discovery and development. The protocols and insights provided in this note serve as a validated starting point for scientists looking to integrate this powerful and green chemical technique into their laboratories.

References

- **Microwaves in Organic Synthetic Chemistry- A Greener Approach to Environmental Protection: An Overview.** (2024). International Journal of Trend in Scientific Research and Development. [\[Link\]](#)
- **Gudle, A., Paret, S., & Dalimba, U.** (2025). Microwave-Assisted Organic Synthesis: An Eco-Friendly Method of Green Chemistry. MDPI. [\[Link\]](#)
- **Microwave-Assisted Organic Synthesis: A Green Chemistry Strategy.** (n.d.). International Journal of Research in Pharmacy and Allied Science. [\[Link\]](#)

- Al-Sanea, M. M., et al. (2021). Microwave-Assisted Synthesis, Structural Characterization and Assessment of the Antibacterial Activity of Some New Aminopyridine, Pyrrolidine, Piperidine and Morpholine Acetamides. MDPI. [[Link](#)]
- Importance of Microwave Heating In Organic Synthesis. (2022). ResearchGate. [[Link](#)]
- Biris, A. R., et al. (2021). Impact of Microwaves on Organic Synthesis and Strategies toward Flow Processes and Scaling Up. ACS Publications. [[Link](#)]
- Cao, H., et al. (2025). Microwave-assisted direct amidation of thioesters: a green approach. Organic & Biomolecular Chemistry (RSC Publishing). [[Link](#)]
- Microwaves-assisted solvent-free synthesis of N-acetamides by amidation or aminolysis. (n.d.). ScienceDirect. [[Link](#)]
- Charville, H., et al. (2020). Microwave-Assisted Catalytic Method for a Green Synthesis of Amides Directly from Amines and Carboxylic Acids. PMC. [[Link](#)]
- Microwaves-assisted solvent-free synthesis of N-acetamides by amidation or aminolysis | Request PDF. (2025). ResearchGate. [[Link](#)]
- Microwave-assisted One-pot Synthesis of Amide Bond using WEB. (n.d.). Bentham Science. [[Link](#)]
- Microwave Reaction Tutorial. (2020). Biotage. [[Link](#)]
- Microwave Assisted Reactions for Synthesis of Bioactive Azaheterocycles. (2020). ResearchGate. [[Link](#)]
- Microwave Assisted Synthesis Of New Heterocyclic Compounds. (2024). International Journal of Pharmaceutical Sciences. [[Link](#)]
- Synthesis of β -amyloid (1-42) using microwave heating on the Biotage® Initiator+ Alstra. (2026). Biotage. [[Link](#)]
- Microwave-Assisted Synthesis of Amide under Solvent-free Conditions. (2025). ResearchGate. [[Link](#)]

- Organic Syntheses Procedure. (n.d.). Organic Syntheses. [[Link](#)]
- Microwave-induced synthesis of bioactive nitrogen heterocycles. (2024). EurekaAlert!. [[Link](#)]
- Microwave-Induced Synthesis of Bioactive Nitrogen Heterocycles. (2024). Bentham Science Publishers. [[Link](#)]
- Microwave-Assisted Catalytic Method for a Green Synthesis of Amides Directly from Amines and Carboxylic Acids. (2020). MDPI. [[Link](#)]
- Biotage microwave reaction tutorial for the teaching laboratory. (2015). Norlab. [[Link](#)]
- microwave-assisted synthesis of nitrogen heterocycles. (n.d.). [[Link](#)]
- Solvent-free efficient microwave assisted synthesis of α,β -unsaturated compounds and their antimicrobial activity assessment. (2019). OAText. [[Link](#)]
- Initiator+ SPWave - Microwave Peptide Synthesizer. (n.d.). Technoprocur.cz. [[Link](#)]
- Manual. (n.d.). CEM Corporation. [[Link](#)]
- CEM Discover SP Microwave Reactor Manual. (n.d.). [[Link](#)]
- Continuous Flow Microwave Chemistry. (n.d.). AWS. [[Link](#)]
- Operation of the CEM Discover SP Microwave Reaction System for Amino Acid Hydrolysis. (n.d.). [[Link](#)]
- Microwave Assisted Synthesis of Heterocycles- Green Chemistry Approaches. (2017). International Journal of ChemTech Research. [[Link](#)]
- CEM Discover 2.0 Brochure. (n.d.). Cemis-Tech. [[Link](#)]
- Microwave-assisted synthesis of N-heterocycles in medicinal chemistry. (n.d.). IRIS-AperTO. [[Link](#)]
- Microwave-assisted multicomponent reactions in heterocyclic chemistry and mechanistic aspects. (n.d.). PMC. [[Link](#)]

- MICROWAVE-ASSISTED SYNTHETIC APPROACHES TO BIOLOGICALLY ACTIVE N-BASED FIVE-MEMBERED HETEROCYCLES AS RESPONSE TO GREEN CHEMISTR. (n.d.). Revue Roumaine de Chimie. [[Link](#)]

Need Custom Synthesis?

BenchChem offers custom synthesis for rare earth carbides and specific isotopic labeling.

Email: info@benchchem.com or [Request Quote Online](#).

Sources

- [1. benthamscience.com](https://www.benthamscience.com) [[benthamscience.com](https://www.benthamscience.com)]
- [2. ajgreenchem.com](https://www.ajgreenchem.com) [[ajgreenchem.com](https://www.ajgreenchem.com)]
- [3. ijpsjournal.com](https://www.ijpsjournal.com) [[ijpsjournal.com](https://www.ijpsjournal.com)]
- [4. Microwave-Assisted Catalytic Method for a Green Synthesis of Amides Directly from Amines and Carboxylic Acids - PMC](#) [[pmc.ncbi.nlm.nih.gov](https://pubmed.ncbi.nlm.nih.gov)]
- [5. mdpi.com](https://www.mdpi.com) [[mdpi.com](https://www.mdpi.com)]
- [6. pubs.acs.org](https://pubs.acs.org) [pubs.acs.org]
- [7. ijrpas.com](https://www.ijrpas.com) [[ijrpas.com](https://www.ijrpas.com)]
- [8. researchgate.net](https://www.researchgate.net) [[researchgate.net](https://www.researchgate.net)]
- [9. researchgate.net](https://www.researchgate.net) [[researchgate.net](https://www.researchgate.net)]
- [10. Organic Syntheses Procedure](https://www.orgsyn.org) [[orgsyn.org](https://www.orgsyn.org)]
- [11. commons.lbl.gov](https://commons.lbl.gov) [commons.lbl.gov]
- [12. cemis.tech](https://www.cemis.tech) [[cemis.tech](https://www.cemis.tech)]
- [13. biotage.com](https://www.biotage.com) [[biotage.com](https://www.biotage.com)]
- [14. chem.kmu.edu.tw](https://chem.kmu.edu.tw) [chem.kmu.edu.tw]
- [15. mdpi.com](https://www.mdpi.com) [[mdpi.com](https://www.mdpi.com)]
- [16. mdpi.com](https://www.mdpi.com) [[mdpi.com](https://www.mdpi.com)]
- [17. researchgate.net](https://www.researchgate.net) [[researchgate.net](https://www.researchgate.net)]
- [18. researchgate.net](https://www.researchgate.net) [[researchgate.net](https://www.researchgate.net)]

- To cite this document: BenchChem. [Application Note: Microwave-Assisted Synthesis of N-Heterocyclic Acetamides]. BenchChem, [2026]. [Online PDF]. Available at: [<https://www.benchchem.com/product/b3023428/docs#application-note-microwave-assisted-synthesis-of-n-heterocyclic-acetamides>]

Disclaimer & Data Validity:

The information provided in this document is for Research Use Only (RUO) and is strictly not intended for diagnostic or therapeutic procedures. While BenchChem strives to provide accurate protocols, we make no warranties, express or implied, regarding the fitness of this product for every specific experimental setup.

Technical Support: The protocols provided are for reference purposes. Unsure if this reagent suits your experiment?

Need Industrial/Bulk Grade? [Request Custom Synthesis Quote](#)

BenchChem

Our mission is to be the trusted global source of essential and advanced chemicals, empowering scientists and researchers to drive progress in science and industry.

Contact

Address: 3281 E Guasti Rd
Ontario, CA 91761, United States
Phone: (601) 213-4426
Email: info@benchchem.com

[Contact our Ph.D. Support Team for a compatibility check](#)