

Technical Support Center: Oximation of 4-Methoxybenzaldehyde

Author: BenchChem Technical Support Team. **Date:** May 2026

Compound of Interest

Compound Name: 4-Methoxybenzaldehyde oxime

CAS No.: 3717-22-4

Cat. No.: B3022790

[Get Quote](#)

Welcome to the technical support guide for the oximation of 4-methoxybenzaldehyde. This resource is designed for researchers, chemists, and drug development professionals to navigate the common challenges and side reactions encountered during this synthesis. Here, we move beyond simple protocols to explain the causality behind the procedures, ensuring you can troubleshoot effectively and optimize your results.

Section 1: Troubleshooting Guide - Common Experimental Issues

This section addresses specific problems you may encounter during the synthesis and purification of **4-methoxybenzaldehyde oxime**. Each issue is presented in a question-and-answer format, detailing the probable causes and providing validated solutions.

Q1: My reaction yield is significantly lower than expected. What are the likely causes and how can I improve it?

A1: Low yield is a frequent issue stemming from several potential factors, ranging from reaction conditions to workup procedures.

Probable Causes & Solutions:

- Incomplete Reaction: The reaction may not have reached completion.
 - Solution: Ensure you are using a slight excess of hydroxylamine hydrochloride (typically 1.1 to 1.5 equivalents) to drive the reaction forward. Monitor the reaction progress using Thin Layer Chromatography (TLC) until the 4-methoxybenzaldehyde starting material spot is no longer visible.^[1]
- Suboptimal pH: The reaction is pH-sensitive. The free hydroxylamine base (NH_2OH) is the active nucleophile, but it is generated in situ from its salt ($\text{NH}_2\text{OH}\cdot\text{HCl}$). If the medium is too acidic, the concentration of the free base is too low. If it's too basic, the hydroxylamine can become unstable.
 - Solution: Use a mild base like sodium hydroxide, sodium acetate, or sodium carbonate to neutralize the HCl generated from the hydroxylamine hydrochloride.^{[2][3]} The goal is a final pH that is typically near neutral or slightly basic. An ethanol/water mixture is a common solvent system that facilitates the dissolution of both the organic aldehyde and the inorganic salts.^[1]
- Product Loss During Workup: The oxime product can be lost during extraction or precipitation steps.
 - Solution: After the reaction, the volume of the organic solvent (e.g., ethanol) is often reduced under pressure. The product is then typically precipitated by adding cold water.^[1] ^[2] Ensure the water is sufficiently cold to minimize the solubility of the oxime. If performing an extraction, ensure the pH of the aqueous layer is controlled to prevent the oxime from partitioning unfavorably.^[1]

Troubleshooting Workflow: Low Yield

Below is a logical workflow to diagnose and resolve low-yield issues.

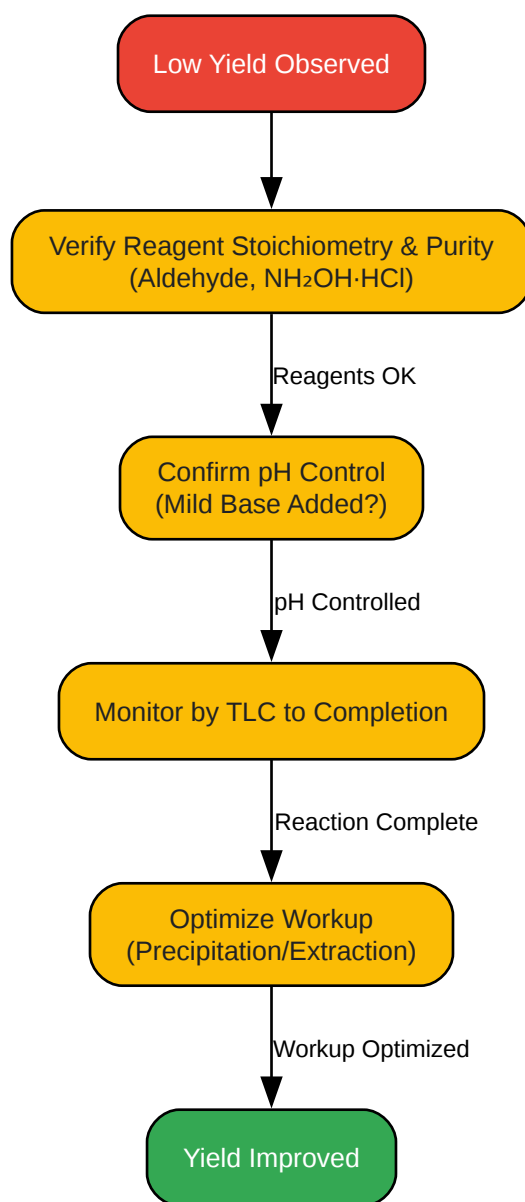

[Click to download full resolution via product page](#)

Caption: A step-by-step workflow for troubleshooting low product yield.

Q2: My final product is contaminated with 4-methoxybenzonnitrile. How did this form and how can I prevent it?

A2: The formation of 4-methoxybenzonnitrile is a classic side reaction resulting from the dehydration of the aldoxime. This process is mechanistically related to the Beckmann

rearrangement.[4][5]

Mechanism & Prevention:

- Causality (Beckmann Rearrangement of an Aldoxime): Under acidic conditions or at high temperatures, the hydroxyl group of the oxime can be protonated, turning it into a good leaving group (water). A subsequent rearrangement and loss of a proton leads to the formation of the nitrile.[4][6]
- Prevention:
 - Temperature Control: Avoid excessive heating. While some protocols use reflux, prolonged exposure to high temperatures can favor dehydration.[1] If possible, conduct the reaction at room temperature or with gentle warming.
 - pH Management: Strictly avoid strongly acidic conditions. The use of a mild base not only facilitates the oximation but also prevents the acidic conditions that catalyze nitrile formation.[1]

Q3: I've isolated my product, but NMR analysis shows unreacted 4-methoxybenzaldehyde. What went wrong?

A3: This is a clear indication of either an incomplete reaction or, more commonly, inefficient purification.

Causes & Solutions:

- Incomplete Reaction: As detailed in Q1, ensure sufficient reaction time and an adequate amount of hydroxylamine hydrochloride.[1]
- Inefficient Purification: The starting aldehyde and the product oxime have similar polarities, which can make separation challenging.
 - Recrystallization: This is the most effective method for purification.[7] An ethanol/water solvent system is often ideal. Dissolve the crude product in a minimum amount of hot ethanol and then add water dropwise until the solution becomes slightly cloudy. Reheat to

clarify and then allow it to cool slowly.[1] This procedure decreases the solubility of the slightly less polar oxime relative to the aldehyde, allowing for its selective crystallization.

- Column Chromatography: If recrystallization is ineffective, column chromatography using a silica gel stationary phase with a non-polar/polar eluent system (e.g., a gradient of ethyl acetate in petroleum ether or hexane) can be used for separation.[1]

Q4: My product appears to be a mixture of E/Z isomers. Is this normal, and can I isolate a single isomer?

A4: Yes, the formation of a mixture of syn (E) and anti (Z) isomers is a very common and expected outcome for the oximation of most aldehydes.[1][7]

Management of Isomers:

- Acceptance: For many subsequent synthetic steps, the mixture of isomers is perfectly acceptable and can be used without separation.[1]
- Separation: If a single isomer is required for stereospecific reactions or characterization, separation can be attempted.
 - Fractional Crystallization: The two isomers may have slightly different solubilities, allowing for separation through careful, repeated recrystallization.
 - Chromatography: Meticulous column chromatography can sometimes resolve the E/Z isomers.[1]
- Influence on Ratio: The ratio of isomers can sometimes be influenced by the choice of solvent and the pH of the reaction, although achieving high selectivity can be difficult.

Section 2: Key Side Reactions Overview

The primary side reactions in this oximation are driven by the reactivity of the aldehyde starting material and the oxime product itself. Understanding these pathways is crucial for optimizing the reaction.

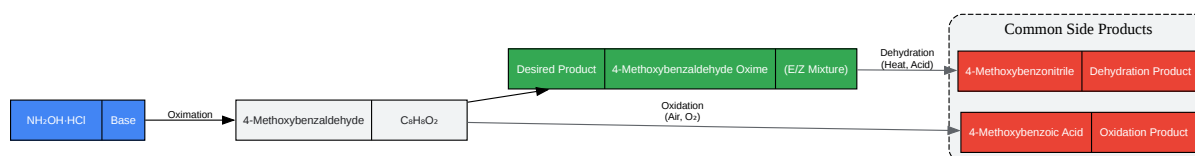

[Click to download full resolution via product page](#)

Caption: The desired oximation pathway and major side reactions.

Section 3: Frequently Asked Questions (FAQs)

Q: What are the standard, baseline conditions for this oximation? A: A widely adopted and reliable method involves dissolving 4-methoxybenzaldehyde in ethanol, followed by the addition of an aqueous solution of hydroxylamine hydrochloride and a mild base such as sodium hydroxide or sodium acetate.^{[2][8]} The reaction can often be performed at room temperature or with gentle heating to reflux for 1-2 hours, with completion monitored by TLC.^[8]

Parameter	Recommended Condition	Rationale
Hydroxylamine	1.1 - 1.5 equivalents	Drives the reaction to completion.
Base	Mild base (NaOH, NaOAc, Na ₂ CO ₃)	Neutralizes HCl, generating the free nucleophile (NH ₂ OH). [2][3]
Solvent	Ethanol/Water	Good solubility for both organic and inorganic reagents.[1]
Temperature	Room Temp to Reflux (e.g., ~80°C)	Balances reaction rate with minimizing side reactions like dehydration.
Monitoring	Thin Layer Chromatography (TLC)	Visual confirmation of the consumption of the starting aldehyde.[1][2]

Q: My product is "oiling out" during recrystallization instead of forming crystals. What should I do? A: "Oiling out" occurs when the solute's solubility is too low in the hot solvent or the solution cools too rapidly, causing it to separate as a liquid phase instead of forming a crystal lattice.[1]

- **Add More Solvent:** Add a small amount of the primary solvent (e.g., hot ethanol) to the oiled-out mixture until it fully redissolves.
- **Slow Cooling:** Allow the flask to cool to room temperature slowly and undisturbed before moving it to an ice bath. Rapid cooling promotes oiling.
- **Induce Crystallization:** Scratch the inside of the flask at the solvent-air interface with a glass rod. The microscopic scratches on the glass can provide nucleation sites for crystal growth.
[1]

Q: Can I use Gas Chromatography-Mass Spectrometry (GC-MS) to check the purity of my oxime product? A: It is strongly advised not to use GC-MS for analyzing benzaldehyde oximes. Oximes are often thermally labile and can decompose in the high temperatures of the GC

injection port. This decomposition can lead to the detection of the parent aldehyde (4-methoxybenzaldehyde) or the nitrile, even if these impurities are not present in your bulk sample, giving a false purity reading.[1] Preferable analytical techniques that operate at lower temperatures include ^1H NMR, LC-MS, and HPLC.[1]

Section 4: Experimental Protocols

Protocol 1: Synthesis of 4-Methoxybenzaldehyde Oxime

This protocol is adapted from established procedures for the synthesis of substituted benzaldehyde oximes.[1][2]

- **Preparation:** In a round-bottom flask equipped with a magnetic stirrer and reflux condenser, dissolve 4-methoxybenzaldehyde (1.0 eq) in ethanol (approx. 5-10 mL per gram of aldehyde).
- **Reagent Addition:** In a separate beaker, prepare a solution of hydroxylamine hydrochloride (1.2 eq) and sodium hydroxide (1.2 eq) in a minimal amount of water.
- **Reaction:** Slowly add the aqueous hydroxylamine solution to the stirred ethanolic solution of the aldehyde at room temperature.
- **Heating & Monitoring:** Heat the mixture to a gentle reflux ($\sim 80^\circ\text{C}$) and monitor the reaction's progress by TLC (e.g., using a 4:1 hexane:ethyl acetate eluent) until the starting aldehyde spot has completely disappeared (typically 1-2 hours).
- **Workup:** Cool the reaction mixture to room temperature. Reduce the volume of ethanol using a rotary evaporator.
- **Precipitation:** Add cold water to the concentrated residue to precipitate the crude oxime product.
- **Isolation:** Collect the white precipitate by filtration using a Buchner funnel, wash the solid with a small amount of cold water, and allow it to air dry or dry under vacuum.[1][2]

Protocol 2: Purification by Recrystallization

- Solvent Selection: An ethanol/water mixture is an excellent choice for **4-methoxybenzaldehyde oxime**.
- Dissolution: Place the crude, dried oxime in an Erlenmeyer flask. Add a minimal amount of hot ethanol and swirl to dissolve the solid completely.
- Induce Precipitation: While the solution is still hot, add water dropwise until the solution just begins to turn persistently cloudy.
- Clarification: Add a few more drops of hot ethanol to redissolve the precipitate and make the solution clear again.
- Crystallization: Cover the flask and allow it to cool slowly to room temperature. White, needle-like crystals should form. Once at room temperature, the flask can be placed in an ice bath to maximize crystal formation.
- Isolation: Collect the purified crystals by vacuum filtration, wash with a small amount of cold ethanol/water, and dry thoroughly.

References

- Chem-Impex. (n.d.). **4-Methoxybenzaldehyde Oxime**. Retrieved from [\[Link\]](#)
- LookChem. (n.d.). 4-Methoxybenzaldehyde 123-11-5 wiki. Retrieved from [\[Link\]](#)
- Master Organic Chemistry. (n.d.). Beckmann Rearrangement. Retrieved from [\[Link\]](#)
- Wikipedia. (n.d.). Beckmann rearrangement. Retrieved from [\[Link\]](#)
- Avila, H. P., et al. (n.d.). An Efficient Procedure for Synthesis of Oximes by Grinding. Asian Journal of Chemistry. Retrieved from [\[Link\]](#)
- Chemistry Steps. (n.d.). The Beckmann Rearrangement. Retrieved from [\[Link\]](#)
- Organic Chemistry Portal. (n.d.). Beckmann Rearrangement. Retrieved from [\[Link\]](#)
- Google Patents. (n.d.). CN112724006A - Method for synthesizing p-methoxybenzaldehyde by using anethole as raw material.

- PubChem. (n.d.). 4-Methoxybenzaldehyde. Retrieved from [[Link](#)]
- ResearchGate. (2020). Figure S14. ¹H NMR (300 MHz, DMSO-d₆) of **4-methoxybenzaldehyde oxime** (21). Retrieved from [[Link](#)]

Need Custom Synthesis?

BenchChem offers custom synthesis for rare earth carbides and specific isotopic labeling.

Email: info@benchchem.com or [Request Quote Online](#).

Sources

- 1. [benchchem.com](https://www.benchchem.com) [[benchchem.com](#)]
- 2. pdf.benchchem.com [[pdf.benchchem.com](#)]
- 3. asianpubs.org [[asianpubs.org](#)]
- 4. masterorganicchemistry.com [[masterorganicchemistry.com](#)]
- 5. Beckmann rearrangement - Wikipedia [en.wikipedia.org]
- 6. Beckmann Rearrangement [organic-chemistry.org]
- 7. smolecule.com [[smolecule.com](#)]
- 8. pdf.benchchem.com [[pdf.benchchem.com](#)]
- To cite this document: BenchChem. [Technical Support Center: Oximation of 4-Methoxybenzaldehyde]. BenchChem, [2026]. [Online PDF]. Available at: [<https://www.benchchem.com/product/b3022790/docs#technical-support-center-oximation-of-4-methoxybenzaldehyde>]

Disclaimer & Data Validity:

The information provided in this document is for Research Use Only (RUO) and is strictly not intended for diagnostic or therapeutic procedures. While BenchChem strives to provide accurate protocols, we make no warranties, express or implied, regarding the fitness of this product for every specific experimental setup.

Technical Support: The protocols provided are for reference purposes. Unsure if this reagent suits your experiment?

Need Industrial/Bulk Grade? [Request Custom Synthesis Quote](#)

BenchChem

Our mission is to be the trusted global source of essential and advanced chemicals, empowering scientists and researchers to drive progress in science and industry.

Contact

Address: 3281 E Guasti Rd
Ontario, CA 91761, United States
Phone: (601) 213-4426
Email: info@benchchem.com

[Contact our Ph.D. Support Team for a compatibility check](#)