

temperature optimization for 4-Aminocyclohexanecarbonitrile hydrochloride reactions

Author: BenchChem Technical Support Team. **Date:** May 2026

Compound of Interest

Compound Name:	4-Aminocyclohexanecarbonitrile hydrochloride
CAS No.:	873537-33-8
Cat. No.:	B3021767

[Get Quote](#)

Technical Support Center: 4-Aminocyclohexanecarbonitrile Hydrochloride Introduction: The Critical Role of Temperature in Bifunctional Systems

4-Aminocyclohexanecarbonitrile hydrochloride is a valuable building block in pharmaceutical and chemical synthesis, featuring two distinct reactive centers: a primary amine and a nitrile group. The reactivity of both functional groups is highly dependent on thermal conditions. Inadequate temperature control is a primary source of failed or low-yielding reactions, leading to impurity generation, starting material decomposition, or stalled conversions.

This guide provides a structured, problem-oriented approach to temperature optimization. It moves beyond simple procedural steps to explain the underlying chemical principles, enabling

researchers to troubleshoot effectively and develop robust, scalable synthetic protocols.

Section 1: Frequently Asked Questions (FAQs)

Q1: What is the general thermal stability of **4-Aminocyclohexanecarbonitrile hydrochloride**?

The hydrochloride salt form is significantly more stable for storage than its freebase counterpart, which can be unstable at room temperature.[1] While specific decomposition temperature data for this exact molecule is not readily available, analogous small organic molecules can undergo thermal decomposition at elevated temperatures.[2][3] It is crucial to assume that prolonged exposure to high temperatures (e.g., >100-120 °C), especially in the presence of reactive reagents, can lead to degradation.

Q2: Why is temperature optimization more critical for this molecule than for a simple monofunctional compound?

This molecule's bifunctional nature creates a landscape of competing reactions, each with its own temperature-dependent rate constant. For example, when reacting a reagent with the amine group, excessive heat might initiate unintended side reactions at the nitrile group (e.g., hydrolysis in aqueous conditions) or vice-versa. Temperature is the primary lever to control the selectivity between these competing pathways.

Q3: My reaction is exothermic. How does this impact my temperature strategy?

For exothermic reactions, such as many acylations or alkylations of the amine group, the initial temperature setting is critical. The primary goal is to prevent a thermal runaway, where the heat generated by the reaction accelerates the reaction rate, generating even more heat.

- Strategy: Start the reaction at a low temperature (e.g., 0 °C) and add the limiting reagent slowly to allow the cooling apparatus to dissipate the generated heat.[4] Once the initial exotherm is controlled, the reaction can often be allowed to warm to room temperature or be gently heated to ensure complete conversion.

Section 2: Troubleshooting Guide - A Problem-Oriented Approach

This section addresses the most common experimental failures and links them directly to potential temperature-related causes.

Issue 1: Low Reaction Yield or Stalled Conversion

Q1.1: I've run my reaction for the prescribed time, but analysis (TLC/LCMS) shows significant unreacted starting material. What is the first temperature-related parameter to check?

The most likely cause is insufficient thermal energy to overcome the reaction's activation energy. Many reactions, particularly those that are not highly exothermic, require heating to proceed at a practical rate.^[5]

- Causality: Chemical reactions occur when molecules collide with sufficient energy (the activation energy). Lowering the temperature reduces the kinetic energy of molecules, leading to fewer successful reactive collisions per unit of time.^[5]
- Solution:
 - Confirm Stability: First, ensure your starting material and desired product are stable at higher temperatures. Run a small-scale experiment where you heat the starting material in the reaction solvent to the proposed new temperature and monitor for decomposition over time.
 - Incremental Increase: Increase the reaction temperature in controlled increments (e.g., 10-15 °C) and monitor the reaction progress at each new setpoint.
 - Reference Similar Reactions: For example, the hydrolysis of nitriles to carboxylic acids almost always requires significant heat, often heating under reflux for several hours.^{[6][7]}

Q1.2: My reaction starts well but then stalls before completion, even with gentle heating. What could be happening?

This can occur if a reaction intermediate is thermally unstable or if an equilibrium is reached.

- Causality: An intermediate may decompose or participate in an unproductive side reaction at the chosen temperature, preventing the reaction from proceeding to the final product.

Alternatively, if the reaction is reversible, you may have reached a thermodynamic equilibrium where the rates of the forward and reverse reactions are equal.

- Solution:
 - Lower the Temperature: Counterintuitively, try running the reaction at a lower temperature for a longer period. This can sometimes disfavor the decomposition pathway of an intermediate.
 - Use a Scavenger: If an inhibitory byproduct is formed (e.g., water in a reaction that needs to be anhydrous), a scavenger or drying agent can be used. If the reaction is reversible, consider adding an excess of one reagent to push the equilibrium forward (Le Châtelier's principle).

Issue 2: High Impurity Profile

Q2.1: My final product is contaminated with multiple byproducts. How can temperature be used to improve purity?

Impurity formation is often a result of running a reaction at too high a temperature, which provides enough energy to activate undesired reaction pathways.

- Causality: Every potential reaction has its own activation energy. By running a reaction at the lowest possible temperature that still allows the desired transformation to occur at a reasonable rate, you can often "freeze out" the higher-energy side reactions.
- Solution: Methodically lower the reaction temperature. This is a classic strategy to enhance selectivity. For example, reducing a nitrile with Diisobutylaluminium hydride (DIBALH) must be done at very low temperatures (e.g., -78 °C) to prevent over-reduction from the aldehyde to the alcohol.[8]

Q2.2: I'm trying to perform an N-alkylation on the amine, but I'm getting a significant amount of the di-alkylated product. How can I control this with temperature?

Over-alkylation is a common issue where the mono-alkylated product, which is also a nucleophile, competes with the starting material for the alkylating agent.[9]

- Causality: This side reaction also has a temperature-dependent rate. While temperature is one factor, stoichiometry is often the primary control. However, running the reaction at a lower temperature can help improve selectivity for the mono-alkylated product.
- Solution:
 - Use a significant excess of the starting amine relative to the alkylating agent.
 - Perform the reaction at the lowest feasible temperature.
 - Add the alkylating agent slowly to a cooled solution of the amine to maintain a low instantaneous concentration of the alkylating agent.

Section 3: Experimental Protocol: Systematic Temperature Optimization

This protocol provides a self-validating workflow for determining the optimal temperature for a given reaction. It relies on parallel experimentation and regular in-process controls (IPCs).

Objective: To identify the temperature that provides the best balance of reaction rate and purity.

Methodology:

- Preparation:
 - Set up three identical small-scale reactions in parallel (e.g., in a multi-well reaction block or three round-bottom flasks in separate heating mantles).
 - Ensure all glassware is properly dried and all reagents are weighed accurately.^[4]
- Temperature Screening:
 - Reaction 1 (Low Temp): Set to a baseline temperature (e.g., 20 °C).
 - Reaction 2 (Mid Temp): Set to a moderately elevated temperature (e.g., 40 °C).
 - Reaction 3 (High Temp): Set to a higher, but still reasonable, temperature (e.g., 60 °C).

- Execution and Monitoring:
 - Start all three reactions simultaneously.
 - After a set time interval (e.g., 1 hour), carefully and quickly take a small aliquot from each reaction for analysis.
 - Analyze each aliquot by a suitable method (TLC or LCMS is preferred) to assess two key metrics:
 - Conversion: The percentage of starting material consumed.
 - Purity: The ratio of the desired product to any visible impurities.
- Data Analysis and Iteration:
 - Continue taking and analyzing samples at regular intervals (e.g., every 1-2 hours).
 - Scenario A (Ideal): The "High Temp" reaction goes to completion fastest with no significant impurity formation. This is your optimal temperature.
 - Scenario B (Rate vs. Purity Trade-off): The "High Temp" reaction is fast but shows significant impurity formation, while the "Mid Temp" reaction is slower but cleaner. The "Mid Temp" is likely the better choice. You may need to run a new experiment between the Mid and High temperatures to fine-tune.
 - Scenario C (No Reaction): None of the reactions show significant conversion. The entire temperature range is too low. Repeat the experiment with a higher temperature range (e.g., 60 °C, 80 °C, 100 °C), after first confirming thermal stability.
- Visualization of Workflow:

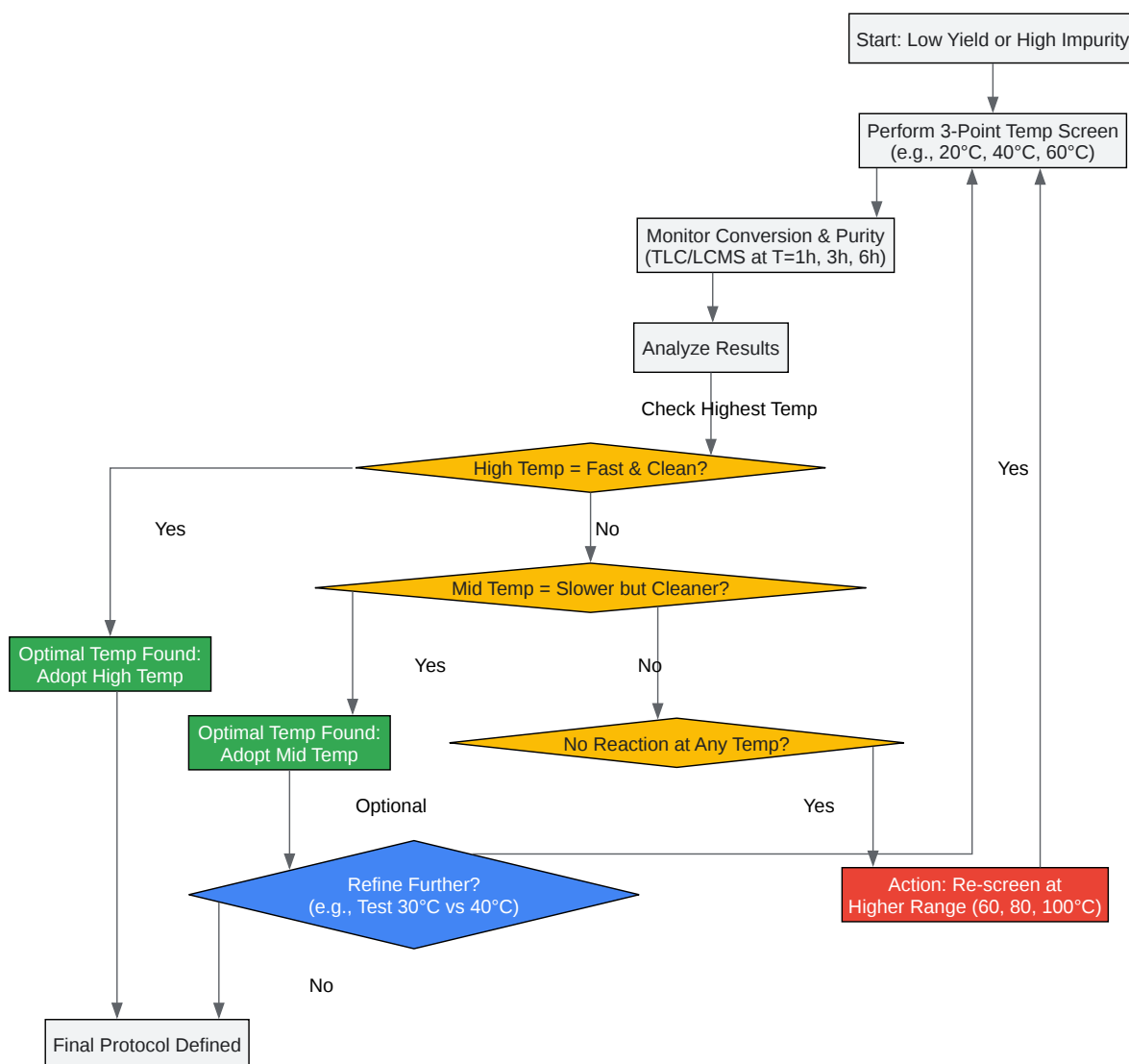

[Click to download full resolution via product page](#)

Caption: Troubleshooting workflow for temperature optimization.

Section 4: Key Temperature-Dependent Side Reactions

Understanding potential side reactions is key to proactive temperature control.

Table 1: Common Reactions and Temperature Considerations

Functional Group	Reaction Type	Typical Temp. Range	Low Temp Risks	High Temp Risks
Amine	N-Acylation	0 °C to 25 °C	Incomplete reaction	Decomposition, di-acylation
Amine	Reductive Amination	20 °C to 50 °C[10]	Slow or stalled reaction	Reduction of other groups, side products
Amine	N-Alkylation	25 °C to 80 °C	Incomplete reaction	Over-alkylation[9], elimination, disproportionation[11]
Nitrile	Acid/Base Hydrolysis	80 °C to 100 °C (Reflux)[6]	Stalled at amide intermediate or no reaction	Decomposition of starting material or product[12]
Nitrile	Reduction (LiAlH ₄)	0 °C to 35 °C	Incomplete reaction	Uncontrolled exotherm, side reactions
Nitrile	Reduction (DIBALH)	-78 °C[8]	Incomplete reaction	Over-reduction to amine

Diagram: Temperature Effects on Reaction Selectivity

Elevated temperatures can provide sufficient energy to access alternative reaction pathways, leading to undesired products. This diagram illustrates how a lower temperature (T1) favors the formation of the desired kinetic product, while a higher temperature (T2) allows the reaction to

overcome a larger activation energy barrier (E_{a2}) to form a more stable, but undesired, thermodynamic byproduct.

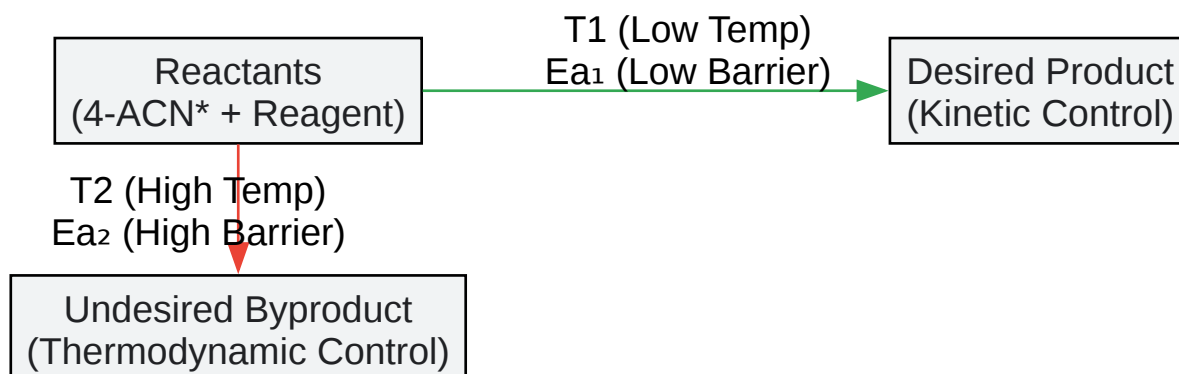

[Click to download full resolution via product page](#)

Need Custom Synthesis?

BenchChem offers custom synthesis for rare earth carbides and specific isotopic labeling.

Email: info@benchchem.com or [Request Quote Online](#).

Sources

- [1. researchgate.net](https://www.researchgate.net) [[researchgate.net](https://www.researchgate.net)]
- [2. taylorandfrancis.com](https://www.taylorandfrancis.com) [[taylorandfrancis.com](https://www.taylorandfrancis.com)]
- [3. researchgate.net](https://www.researchgate.net) [[researchgate.net](https://www.researchgate.net)]
- [4. Troubleshooting](https://chem.rochester.edu) [chem.rochester.edu]
- [5. solutions.bocsci.com](https://solutions.bocsci.com) [solutions.bocsci.com]
- [6. chem.libretexts.org](https://chem.libretexts.org) [chem.libretexts.org]
- [7. savemyexams.com](https://www.savemyexams.com) [[savemyexams.com](https://www.savemyexams.com)]
- [8. chem.libretexts.org](https://chem.libretexts.org) [chem.libretexts.org]
- [9. chem.libretexts.org](https://chem.libretexts.org) [chem.libretexts.org]
- [10. researchgate.net](https://www.researchgate.net) [[researchgate.net](https://www.researchgate.net)]
- [11. bibliotekanauki.pl](https://bibliotekanauki.pl) [bibliotekanauki.pl]

- 12. 'Dry' hydrolysis of nitriles effected by microwave heating - Journal of the Chemical Society, Perkin Transactions 2 (RSC Publishing) [pubs.rsc.org]
- To cite this document: BenchChem. [temperature optimization for 4-Aminocyclohexanecarbonitrile hydrochloride reactions]. BenchChem, [2026]. [Online PDF]. Available at: [https://www.benchchem.com/product/b3021767/docs#temperature-optimization-for-4-aminocyclohexanecarbonitrile-hydrochloride-reactions]

Disclaimer & Data Validity:

The information provided in this document is for Research Use Only (RUO) and is strictly not intended for diagnostic or therapeutic procedures. While BenchChem strives to provide accurate protocols, we make no warranties, express or implied, regarding the fitness of this product for every specific experimental setup.

Technical Support: The protocols provided are for reference purposes. Unsure if this reagent suits your experiment?

Need Industrial/Bulk Grade? [Request Custom Synthesis Quote](#)

BenchChem

Our mission is to be the trusted global source of essential and advanced chemicals, empowering scientists and researchers to drive progress in science and industry.

Contact

Address: 3281 E Guasti Rd
Ontario, CA 91761, United States
Phone: (601) 213-4426
Email: info@benchchem.com

[Contact our Ph.D. Support Team for a compatibility check](#)