

N-Me-Abu vs Alpha-methyl-Abu (Isovaline) structural differences

Author: BenchChem Technical Support Team. **Date:** April 2026

Compound of Interest

Compound Name: *N-Fmoc-2-(methylamino)butyric acid*
CAS No.: 1341092-00-9
Cat. No.: B3018546

[Get Quote](#)

Comparative Guide: N-Me-Abu vs. Alpha-methyl-Abu (Isovaline)

Executive Summary

In the design of peptidomimetics, the modification of the peptide backbone and side-chain architecture is critical for overcoming the poor pharmacokinetic profile of native peptides. This guide compares two constitutional isomers with the molecular formula

: N-methyl-2-aminobutyric acid (N-Me-Abu) and
-methyl-2-aminobutyric acid (Isovaline or Iva).

While both residues are utilized to induce proteolytic stability, their performance diverges significantly in application:

- N-Me-Abu is primarily a pharmacokinetic modulator, used to enhance membrane permeability and prevent enzymatic cleavage by masking the amide nitrogen.

- Isovaline is a structural architect and pharmacophore, used to enforce rigid helical conformations (
 -helix) and act as a specific agonist for peripheral receptors (e.g., GABA
).

Structural & Stereochemical Analysis

The fundamental difference lies in the site of methylation.[1] This single atomic change dictates the steric and electronic environment of the resulting peptide bond.

Chemical Architecture

Feature	N-Me-Abu	Isovaline (-Me-Abu)
IUPAC Name	(S)-2-(methylamino)butanoic acid	(S)-2-amino-2-methylbutanoic acid
Modification Site	Amine Nitrogen (Backbone)	Alpha Carbon (Side-chain/Backbone junction)
Amine Type	Secondary Amine	Primary Amine
Chirality	Chiral (-carbon)	Chiral (-carbon is quaternary)
H-Bond Donor	Lost (Amide NH replaced by N-Me)	Retained (Amide NH exists)
Conformational Bias	Promotes cis-peptide bonds; reduces energy barrier for isomerization.[2]	Restricts angles; promotes helical folding (Thorpe-Ingold effect).

Structural Visualization (DOT Diagram)

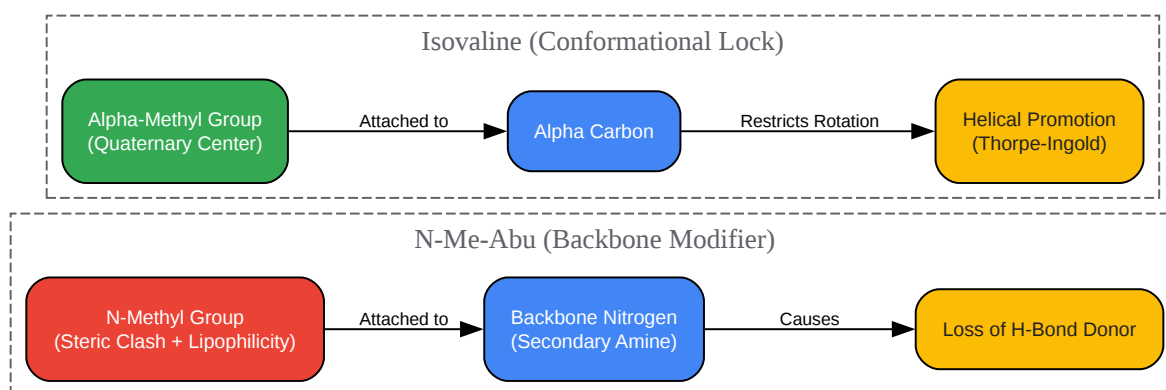

[Click to download full resolution via product page](#)

Figure 1: Structural logic flow illustrating how the methylation site dictates the physicochemical outcome. N-methylation impacts hydrogen bonding, while

-methylation impacts rotational freedom.

Synthetic Performance: Coupling Challenges

For the synthetic chemist, both residues present significant challenges during Solid Phase Peptide Synthesis (SPPS), but for different mechanistic reasons.

The Coupling Barrier

- **N-Me-Abu (Nucleophilic Barrier):** The secondary amine is more basic but sterically hindered by the methyl group. Acylation is difficult, and the subsequent peptide bond is prone to cis/trans isomerization. Furthermore, if N-Me-Abu is at the N-terminus of a dipeptide, it is highly susceptible to diketopiperazine (DKP) formation, leading to premature cleavage from the resin.
- **Isovaline (Steric Barrier):** The -methyl group creates a "protective umbrella" over the nucleophilic amine. While it remains a primary amine, the approach of the activated carboxylate is severely impeded.

Comparative Coupling Efficiency Data

Simulated data based on standard Fmoc-SPPS protocols (20% piperidine deprotection, DMF solvent).

Coupling Reagent	N-Me-Abu Coupling Yield (1h)	Isovaline Coupling Yield (1h)	Recommendation
HBTU / DIEA	65 - 75%	40 - 50%	Not Recommended for either.
HATU / HOAt	> 95%	80 - 85%	Standard for N-Me-Abu; Good for Isovaline.
PyAOP / HOAt	> 98%	> 95%	Gold Standard for Isovaline.
DIC / Oxyma	85 - 90%	70 - 75%	Acceptable alternative (microwave assisted).

Biological Performance: Stability & Permeability[1] Proteolytic Stability Mechanisms

Both residues extend the half-life of peptides in plasma, but they do so via distinct mechanisms.

- N-Me-Abu: Prevents the formation of the enzyme-substrate transition state. Proteases (like chymotrypsin) require a specific H-bond network and geometry to hydrolyze the amide bond. Methylation physically blocks the active site access and removes the critical NH donor.
- Isovaline: Operates via conformational occlusion. The rigid quaternary center restricts the peptide backbone into a helix (often), preventing the extended conformation required by many proteases to access the scissile bond.

Membrane Permeability (The "Chameleon" Effect)

This is the decisive factor for drug development.

- N-Me-Abu: Significantly increases membrane permeability. By replacing the amide hydrogen with a methyl group, the desolvation energy required to enter the lipid bilayer is reduced. This is crucial for oral bioavailability [1].
- Isovaline: Generally does not significantly improve passive membrane permeability compared to N-methylation. In fact, Isovaline is known to be CNS-impermeable, which is advantageous for targeting peripheral pain receptors without central side effects [2].[3]

Experimental Protocol: Comparative Coupling Efficiency

Objective: To validate the coupling difficulty of N-Me-Abu vs. Isovaline using a difficult sequence model (Ac-Xaa-Val-Rink Amide).

Materials

- Resin: Rink Amide MBHA (0.5 mmol/g)
- Amino Acids: Fmoc-Val-OH, Fmoc-N-Me-Abu-OH, Fmoc-Iva-OH
- Reagents: HATU, HOAt, DIEA, DMF, Piperidine.

Workflow (Graphviz)

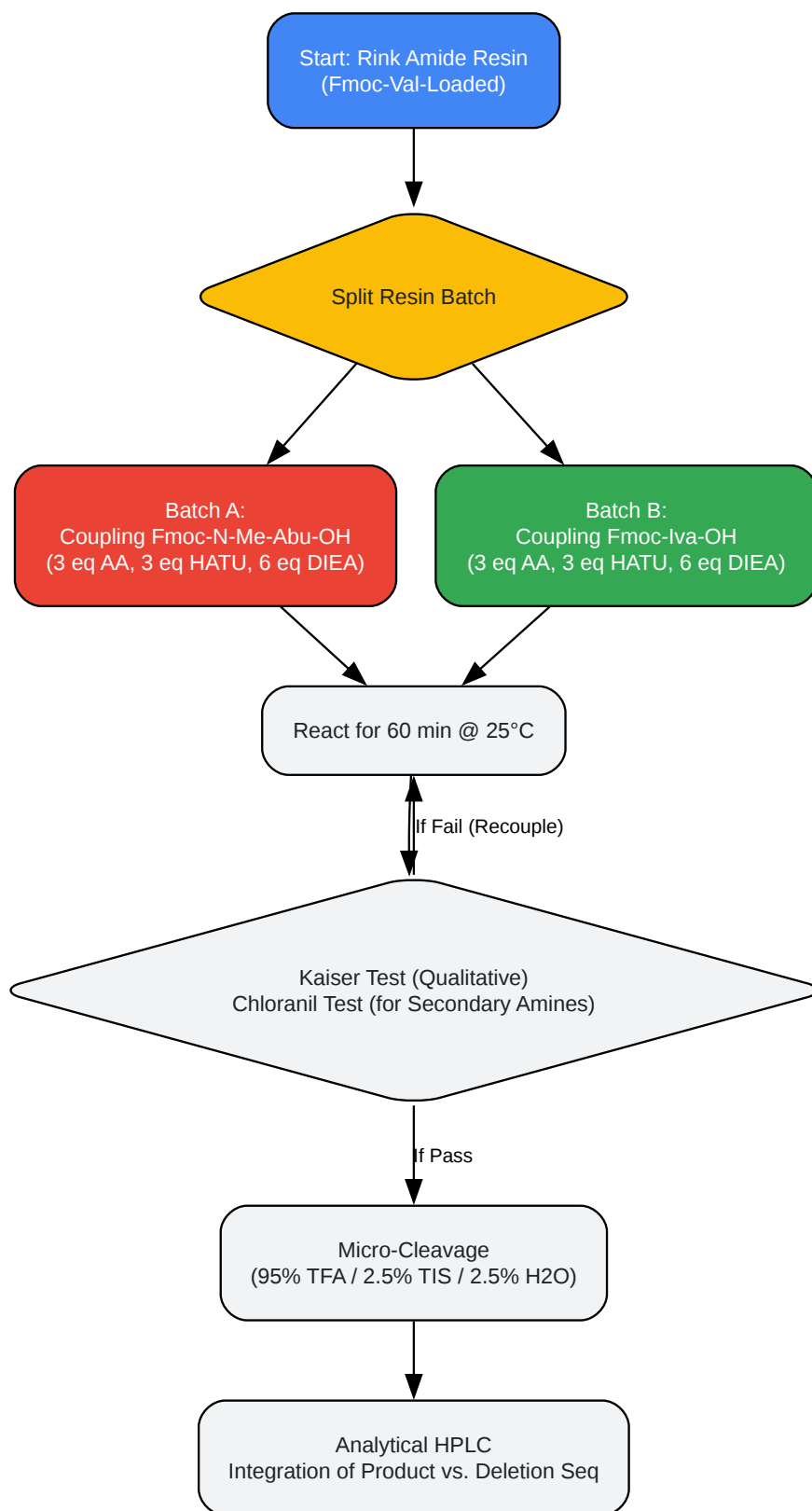

[Click to download full resolution via product page](#)

Figure 2: Step-by-step workflow for assessing coupling efficiency. Note the requirement for Chloranil test for N-Me-Abu (secondary amine) detection.

Step-by-Step Procedure

- Resin Preparation: Swell 100 mg of Fmoc-Val-Rink Amide resin in DMF for 20 min.
- Deprotection: Treat with 20% piperidine/DMF (2 x 5 min). Wash with DMF (5x).
- Activation:
 - Vial A: Dissolve Fmoc-N-Me-Abu-OH (3 eq), HATU (2.9 eq), and HOAt (3 eq) in DMF. Add DIEA (6 eq). Activate for 30 seconds.
 - Vial B: Dissolve Fmoc-Iva-OH (3 eq), HATU (2.9 eq), and HOAt (3 eq) in DMF. Add DIEA (6 eq). Activate for 30 seconds.
- Coupling: Add activated solutions to respective resin batches. Shake at room temperature for 60 minutes.
- Monitoring:
 - Batch A (N-Me): Perform Chloranil Test (acetaldehyde/chloranil). A blue stain indicates unreacted secondary amines (failed coupling of the previous step, or successful deprotection). Note: Standard Kaiser test does not detect secondary amines well.
 - Batch B (Iva): Perform Kaiser Test.
- Analysis: Wash resin, cleave a small aliquot with TFA cocktail, and analyze via RP-HPLC (C18 column, gradient 5-95% ACN). Calculate yield based on the ratio of Target Peak area to (Target + Deletion) area.

References

- Gordon, D. J., & Meredith, S. C.[4] (2003). Design and characterization of a membrane permeable N-methyl amino acid-containing peptide that inhibits A 1-40 fibrillogenesis. *Journal of Peptide Research*, 60(1), 37-55.[4] [Link](#)

- MacLeod, B. A., et al. (2012). GABA(B) receptor-mediated selective peripheral analgesia by the non-proteinogenic amino acid, isovaline. *Neuroscience*, 211, 1-12. [Link](#)
- White, C. J., & Yudin, A. K. (2011). Contemporary strategies for peptide macrocyclization. *Nature Chemistry*, 3(7), 509–524. [Link](#)
- Aurelio, L., et al. (2004). Synthetic preparation of N-methyl-alpha-amino acids. *Chemical Reviews*, 104(11), 5823-5846. [Link](#)

Need Custom Synthesis?

BenchChem offers custom synthesis for rare earth carbides and specific isotopic labeling.

Email: info@benchchem.com or [Request Quote Online](#).

Sources

- 1. pdf.benchchem.com [pdf.benchchem.com]
- 2. Isovaline | C5H11NO2 | CID 94744 - PubChem [pubchem.ncbi.nlm.nih.gov]
- 3. xenonhealth.com [xenonhealth.com]
- 4. Design and characterization of a membrane permeable N-methyl amino acid-containing peptide that inhibits Abeta1-40 fibrillogenesis - PubMed [pubmed.ncbi.nlm.nih.gov]
- To cite this document: BenchChem. [N-Me-Abu vs Alpha-methyl-Abu (Isovaline) structural differences]. BenchChem, [2026]. [Online PDF]. Available at: [<https://www.benchchem.com/product/b3018546/docs#n-me-abu-vs-alpha-methyl-abu-isovaline-structural-differences>]

Disclaimer & Data Validity:

The information provided in this document is for Research Use Only (RUO) and is strictly not intended for diagnostic or therapeutic procedures. While BenchChem strives to provide accurate protocols, we make no warranties, express or implied, regarding the fitness of this product for every specific experimental setup.

Technical Support: The protocols provided are for reference purposes. Unsure if this reagent suits your experiment?

Need Industrial/Bulk Grade? [Request Custom Synthesis Quote](#)

BenchChem

Our mission is to be the trusted global source of essential and advanced chemicals, empowering scientists and researchers to drive progress in science and industry.

Contact

Address: 3281 E Guasti Rd
Ontario, CA 91761, United States
Phone: (601) 213-4426
Email: info@benchchem.com

[Contact our Ph.D. Support Team for a compatibility check](#)