

Advanced Synthesis Protocol: 4-Bromo-5-chloro-2-methoxybenzoic acid

Author: BenchChem Technical Support Team. **Date:** May 2026

Compound of Interest

Compound Name: 4-Bromo-5-chloro-2-methoxybenzoic acid

CAS No.: 1239770-84-3

Cat. No.: B3013550

[Get Quote](#)

Executive Summary & Strategic Rationale

This Application Note details the regioselective synthesis of **4-Bromo-5-chloro-2-methoxybenzoic acid**, a critical scaffold in the development of 5-HT₄ agonists and kinase inhibitors.

The Synthetic Challenge: Direct halogenation of 2-methoxybenzoic acid or 5-chloro-2-methoxybenzoic acid is not viable for this target. The methoxy group (strong ortho/para director) directs electrophilic aromatic substitution to the C3 or C5 positions. With C5 blocked by chlorine, direct bromination would predominantly yield the C3-bromo isomer (ortho to the methoxy group), not the desired C4-bromo target.

The Solution: To achieve the 4-bromo substitution pattern, we employ a Sandmeyer-based strategy utilizing an amino group at the C4 position as a directing handle. The synthesis proceeds via the commercially available or easily synthesized 4-amino-5-chloro-2-methoxybenzoic acid (or its ester). This route guarantees 100% regioselectivity for the C4-bromo substituent.

Retrosynthetic Analysis

The synthesis is deconstructed into three phases:

- Scaffold Functionalization: Establishing the 5-chloro-2-methoxy pattern on a 4-aminobenzoic acid core.
- Sandmeyer Transformation: Converting the C4-amino group to a C4-bromo group via a diazonium intermediate.
- Hydrolysis: Unmasking the carboxylic acid.

Chemical Pathway Visualization

The following diagram illustrates the optimized synthetic workflow, highlighting the critical intermediate transitions.

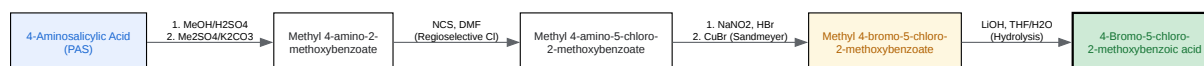

[Click to download full resolution via product page](#)

Figure 1: Step-wise synthetic route from 4-Aminosalicylic acid to the target **4-Bromo-5-chloro-2-methoxybenzoic acid**.

Detailed Experimental Protocols

Phase 1: Precursor Preparation (Scaffold Construction)

Note: If starting from commercially available 4-amino-5-chloro-2-methoxybenzoic acid (CAS 7206-70-4), proceed directly to Phase 2. However, for cost-efficiency, the ester synthesis below is recommended.

Step 1.1: Synthesis of Methyl 4-amino-5-chloro-2-methoxybenzoate

Reaction Logic: We utilize N-Chlorosuccinimide (NCS) rather than chlorine gas. The amino group at C4 and methoxy at C2 synergistically activate the C5 position. NCS provides a controlled source of electrophilic chlorine, preventing over-chlorination.

Reagents:

- Methyl 4-amino-2-methoxybenzoate (1.0 eq)
- N-Chlorosuccinimide (NCS) (1.05 eq)
- Dimethylformamide (DMF) (5 vol)

Protocol:

- Dissolution: Dissolve Methyl 4-amino-2-methoxybenzoate (e.g., 100 g) in DMF (500 mL) at room temperature.
- Addition: Add NCS (1.05 eq) portion-wise over 30 minutes. The reaction is slightly exothermic; maintain temperature < 40°C.
- Reaction: Heat the mixture to 50°C and stir for 4 hours. Monitor by HPLC (Target retention time shift due to Cl addition).
- Quench: Pour the reaction mixture into ice-water (2 L) with vigorous stirring.
- Isolation: The product precipitates as an off-white solid. Filter and wash with water (3 x 200 mL) to remove residual DMF and succinimide.
- Drying: Dry in a vacuum oven at 45°C.
 - Yield Expectation: 85-90%
 - Identity Check: 1H NMR should show loss of H5 proton and retention of H3 and H6 singlets.

Phase 2: The Sandmeyer Transformation (Core Protocol)

Reaction Logic: This is the critical step. We convert the amino group to a diazonium salt, then displace it with bromide using Copper(I) Bromide. Performing this on the methyl ester (CAS 1239743-42-0) is superior to the free acid because it prevents zwitterion formation and improves solubility in the organic phase required for the radical mechanism.

Reagents:

- Methyl 4-amino-5-chloro-2-methoxybenzoate (from Phase 1)
- Sodium Nitrite (NaNO₂) (1.2 eq)
- Hydrobromic Acid (48% aq) (excess)
- Copper(I) Bromide (CuBr) (0.5 - 1.0 eq)
- Acetonitrile/Water (Solvent system)

Protocol:

- Diazotization:
 - Charge Methyl 4-amino-5-chloro-2-methoxybenzoate (50 g) into a reactor containing 48% HBr (200 mL) and water (100 mL). Cool to 0-5°C.
 - Prepare a solution of NaNO₂ (1.2 eq) in water (minimum volume).
 - Add NaNO₂ solution dropwise, maintaining internal temperature < 5°C. Stir for 30 mins.
 - Checkpoint: Solution becomes clear/yellowish. Confirm excess nitrite with starch-iodide paper (turns blue). Destroy excess nitrite with a small amount of urea if necessary.
- Sandmeyer Displacement:
 - In a separate vessel, dissolve CuBr (0.5 eq) in 48% HBr (50 mL) and heat to 60°C.
 - Transfer the cold diazonium solution slowly into the hot CuBr solution. Nitrogen gas evolution will be vigorous.

- Caution: Ensure adequate venting for N₂ gas.
- After addition, stir at 70°C for 1 hour.
- Work-up:
 - Cool to room temperature.[1] Dilute with water (500 mL).
 - Extract with Ethyl Acetate (3 x 200 mL).
 - Wash combined organics with 1M Na₂SO₃ (to remove traces of bromine), then brine.
 - Dry over Na₂SO₄ and concentrate to yield the crude bromo-ester.
 - Purification: Recrystallize from Methanol/Water or pass through a short silica plug if dark colored.

Phase 3: Hydrolysis to Final Target

Reaction Logic: Mild basic hydrolysis cleaves the methyl ester without affecting the aryl halides.

Reagents:

- Methyl 4-bromo-5-chloro-2-methoxybenzoate (Crude from Phase 2)
- Lithium Hydroxide (LiOH) or NaOH (2.0 eq)
- THF/Water (3:1 ratio)

Protocol:

- Dissolve the ester in THF/Water.
- Add LiOH (2.0 eq). Stir at room temperature for 4-6 hours.
- Monitor: TLC/HPLC should show disappearance of the ester peak.
- Isolation:

- Evaporate THF under reduced pressure.
- Acidify the remaining aqueous phase with 1M HCl to pH 2-3.
- The product, **4-Bromo-5-chloro-2-methoxybenzoic acid**, will precipitate as a white/beige solid.
- Filter, wash with water, and dry.

Analytical Characterization

To validate the synthesis, compare analytical data against the following predicted parameters.

| Parameter | Specification | Notes |
|---|---|---|
| Appearance | Off-white to beige powder | Typical for poly-halogenated benzoic acids. |
| Purity (HPLC) | > 98.0% | Major impurity: De-brominated byproduct (rare if Sandmeyer is controlled). |
| ¹ H NMR (DMSO-d ₆) | δ 13.0 (br s, 1H, COOH) δ 7.85 (s, 1H, Ar-H6) δ 7.60 (s, 1H, Ar-H3) δ 3.85 (s, 3H, OMe) | Diagnostic: Two singlets in the aromatic region confirm the para-relationship of protons (positions 3 and 6), proving the 4,5-substitution pattern. |
| Mass Spec (ESI) | [M-H] ⁻ 263.5/265.5 | Characteristic Br/Cl isotope pattern (approx 3:1 intensity ratio for M/M+2/M+4 due to ⁷⁹ Br/ ⁸¹ Br and ³⁵ Cl/ ³⁷ Cl). |

Mechanistic Insight: The Sandmeyer Cycle

The conversion of the amino group to the bromide is the defining step. Understanding the radical mechanism is essential for troubleshooting low yields.

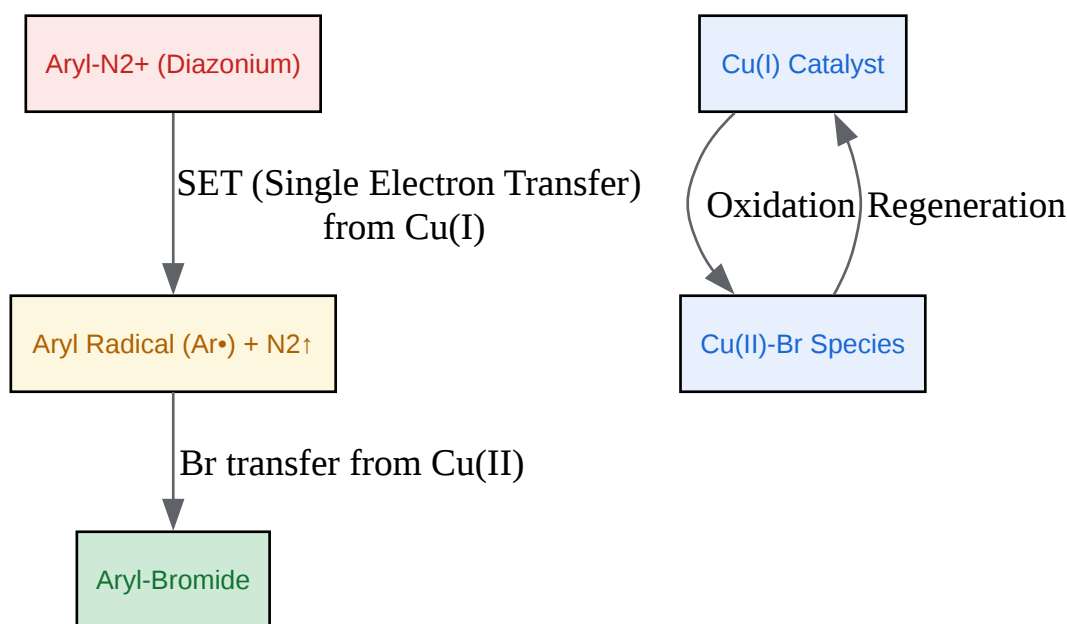

[Click to download full resolution via product page](#)

Figure 2: Radical-Nucleophilic Aromatic Substitution (SRNAr) mechanism. The Cu(I) acts as a single-electron donor to generate the aryl radical, which then abstracts a bromine atom from the Cu(II) species.

Safety & Handling

- Diazonium Salts: The intermediate diazonium salt is potentially explosive if allowed to dry. Always keep it in solution and cold (0-5°C) until the transfer to the copper solution.
- Hydrobromic Acid: Highly corrosive. Use acid-resistant gloves and work in a fume hood.
- Nitrosamines: The reaction generates nitrous acid. Avoid contact with secondary amines to prevent the formation of carcinogenic nitrosamines.

References

- Organic Chemistry Portal. (n.d.). Sandmeyer Reaction: Mechanism and Examples. Retrieved from [\[Link\]](#)
- Synix Labs. (n.d.). Product List: **4-Bromo-5-chloro-2-methoxybenzoic acid** (CAS 1239770-84-3).[\[2\]](#)[\[3\]](#)[\[4\]](#)[\[5\]](#) Retrieved from [\[Link\]](#)

- Wang, Z. (2010). Comprehensive Organic Name Reactions and Reagents. John Wiley & Sons. (General reference for Sandmeyer conditions).

Need Custom Synthesis?

BenchChem offers custom synthesis for rare earth carbides and specific isotopic labeling.

Email: info@benchchem.com or [Request Quote Online](#).

Sources

- [1. lscollge.ac.in \[lscollge.ac.in\]](http://lscollge.ac.in)
- [2. 1820707-08-1|3,5-Dibromo-4-chloro-2-hydroxybenzoic acid|BLD Pharm \[bldpharm.com\]](#)
- [3. 1239743-42-0|Methyl 4-bromo-5-chloro-2-methoxybenzoate|BLD Pharm \[bldpharm.com\]](#)
- [4. 30310-22-6,2-bromo-4-methylpentane-AccelaChem|AccelaChemBio|Accela design, synthesis, manufacture and market advanced R&D chemicals;韶远科技（上海）有限公司 \[accelachem.com\]](#)
- [5. calpaclab.com \[calpaclab.com\]](http://calpaclab.com)
- To cite this document: BenchChem. [Advanced Synthesis Protocol: 4-Bromo-5-chloro-2-methoxybenzoic acid]. BenchChem, [2026]. [Online PDF]. Available at: [\[https://www.benchchem.com/product/b3013550/docs#advanced-synthesis-protocol-4-bromo-5-chloro-2-methoxybenzoic-acid\]](https://www.benchchem.com/product/b3013550/docs#advanced-synthesis-protocol-4-bromo-5-chloro-2-methoxybenzoic-acid)

Disclaimer & Data Validity:

The information provided in this document is for Research Use Only (RUO) and is strictly not intended for diagnostic or therapeutic procedures. While BenchChem strives to provide accurate protocols, we make no warranties, express or implied, regarding the fitness of this product for every specific experimental setup.

Technical Support: The protocols provided are for reference purposes. Unsure if this reagent suits your experiment?

Need Industrial/Bulk Grade? [Request Custom Synthesis Quote](#)

BenchChem

Our mission is to be the trusted global source of essential and advanced chemicals, empowering scientists and researchers to drive progress in science and industry.

Contact

Address: 3281 E Guasti Rd

Ontario, CA 91761, United States

Phone: (601) 213-4426

Email: info@benchchem.com

[Contact our Ph.D. Support Team for a compatibility check](#)