

# Technical Support Center: ALX-5407 Hydrochloride Experiments

**Author:** BenchChem Technical Support Team. **Date:** April 2026

## Compound of Interest

Compound Name: ALX-5407 hydrochloride

CAS No.: 200006-08-2

Cat. No.: B030177

[Get Quote](#)

This technical support center provides troubleshooting guides and frequently asked questions (FAQs) to help researchers, scientists, and drug development professionals minimize variability in experiments involving **ALX-5407 hydrochloride**.

## Frequently Asked Questions (FAQs)

Q1: What is **ALX-5407 hydrochloride** and what is its primary mechanism of action?

**ALX-5407 hydrochloride** is a potent, selective, and non-transportable inhibitor of the glycine transporter 1 (GlyT1).[1][2] Its primary mechanism of action is to block the reuptake of glycine from the synaptic cleft, thereby increasing extracellular glycine concentrations.[3] This enhancement of glycine levels potentiates the activity of N-methyl-D-aspartate (NMDA) receptors, as glycine is a required co-agonist for their activation.[2][4][5][6]

Q2: What are the recommended solvents and storage conditions for **ALX-5407 hydrochloride**?

**ALX-5407 hydrochloride** is soluble in dimethyl sulfoxide (DMSO) and ethanol. Stock solutions should be stored at -20°C or -80°C.[7][8] It is advisable to prepare single-use aliquots to avoid

repeated freeze-thaw cycles, which can degrade the compound.[7] For in vivo studies, a common vehicle formulation involves dissolving the compound in a mixture of DMSO, PEG300, Tween-80, and saline.[7]

Q3: What are the known off-target effects of **ALX-5407 hydrochloride**?

While ALX-5407 is highly selective for GlyT1, high concentrations may lead to off-target effects. It has been shown to have very low affinity for the glycine site on the NMDA receptor and for the GlyT2 transporter.[8] However, at higher doses, it may activate strychnine-sensitive glycine receptors, which could lead to inhibitory effects on motor activity and respiration.

Q4: How does **ALX-5407 hydrochloride** affect downstream signaling pathways?

The primary downstream effect of ALX-5407 is the potentiation of NMDA receptor signaling due to increased synaptic glycine.[2][4][5][6] In specific cellular contexts, such as in Th1 cells, ALX-5407 has been shown to inhibit the MAPK signaling pathway while activating the PI3K-Akt-mTOR pathway.[9]

## Troubleshooting Guides

### In Vitro Cell-Based Assays

#### Issue 1: High Variability in Glycine Uptake Assays

- Potential Cause: Inconsistent cell density.
  - Solution: Ensure a uniform cell seeding density across all wells. Cell confluency can significantly impact transporter expression and activity.
- Potential Cause: Fluctuation in incubation times.
  - Solution: Use a multichannel pipette or automated liquid handling system to ensure simultaneous addition of substrate and inhibitor solutions to all wells.
- Potential Cause: Interference from media components.
  - Solution: Perform assays in a defined buffer system (e.g., Hanks' Balanced Salt Solution) to avoid competition from amino acids or other components in the culture medium.

## Issue 2: Compound Precipitation in Aqueous Media

- Potential Cause: Poor aqueous solubility of **ALX-5407 hydrochloride**.
  - Solution: Prepare a high-concentration stock solution in 100% DMSO and then dilute it to the final working concentration in the assay medium. Ensure the final DMSO concentration is low (typically <0.5%) to avoid solvent-induced cytotoxicity.
- Potential Cause: Saturation of the compound in the final dilution.
  - Solution: Lower the stock solution concentration and adjust the dilution factor accordingly to prevent the compound from crashing out of solution.

## Issue 3: Inconsistent Inhibition (IC50 values vary between experiments)

- Potential Cause: Degradation of **ALX-5407 hydrochloride** stock solution.
  - Solution: Aliquot stock solutions into single-use vials and store them at -20°C or -80°C, protected from light. Avoid repeated freeze-thaw cycles.
- Potential Cause: Variations in cell passage number.
  - Solution: Use cells within a consistent and defined passage number range for all experiments, as transporter expression levels can change with prolonged culturing.

# In Vivo Animal Studies

## Issue 1: Variable Drug Exposure and Efficacy

- Potential Cause: Inconsistent formulation and administration of **ALX-5407 hydrochloride**.
  - Solution: Use a consistent and well-defined vehicle for administration. A common formulation includes DMSO, PEG300, Tween-80, and saline to ensure solubility and stability.<sup>[7]</sup> Ensure accurate and consistent dosing for all animals.
- Potential Cause: Differences in animal metabolism.

- Solution: Consider the metabolic profile of the animal model. For instance, cytochrome P450 2D6 extensive metabolizers were specifically selected in some clinical studies to limit pharmacokinetic variability.[10]

#### Issue 2: Unexpected Behavioral or Physiological Effects

- Potential Cause: Off-target effects at high doses.
  - Solution: Conduct dose-response studies to identify the optimal therapeutic window that maximizes GlyT1 inhibition without causing adverse effects from potential off-target interactions, such as with strychnine-sensitive glycine receptors.
- Potential Cause: Complex dose-response relationship.
  - Solution: Be aware that GlyT1 inhibitors can exhibit complex, sometimes bell-shaped, dose-response curves, where higher doses may lead to reduced efficacy.[10] Careful dose selection based on occupancy studies is crucial.[10][11]

## Data Presentation

Table 1: Physicochemical and In Vitro Properties of **ALX-5407 Hydrochloride**

Property	Value	Reference(s)
Molecular Weight	429.92 g/mol	
Formula	C <sub>24</sub> H <sub>24</sub> FNO <sub>3</sub> ·HCl	
Purity	≥98% (HPLC)	
Solubility in DMSO	Up to 100 mM	
Solubility in Ethanol	Up to 50 mM	
Storage Temperature	Desiccate at +4°C (solid)	
Stock Solution Storage	-20°C or -80°C	[7][8]
GlyT1c IC <sub>50</sub>	3 nM	[1][12]
GlyT2 IC <sub>50</sub>	> 100 μM	[1]
NMDA Receptor IC <sub>50</sub>	> 100 μM	[1]

## Experimental Protocols

### Protocol: In Vitro Glycine Uptake Assay

This protocol provides a general framework for measuring the inhibitory effect of **ALX-5407 hydrochloride** on GlyT1-mediated glycine uptake in a cell-based assay.

- Cell Culture: Plate cells expressing GlyT1 (e.g., CHO-K1/hGlyT1a) in a 96-well or 384-well plate and culture overnight to allow for adherence and recovery.[13]
- Preparation of **ALX-5407 Hydrochloride**: Prepare a stock solution of **ALX-5407 hydrochloride** in 100% DMSO. Serially dilute the stock solution in an appropriate assay buffer (e.g., HBSS) to achieve the desired final concentrations.
- Assay Initiation:
  - Wash the cells with the assay buffer to remove culture medium.
  - Pre-incubate the cells with the diluted **ALX-5407 hydrochloride** or vehicle control for a specified time.

- Add the glycine uptake solution containing a mixture of non-radiolabeled glycine and radiolabeled glycine (e.g., [<sup>3</sup>H]glycine) to initiate the uptake.
- Incubation: Incubate the plate at 37°C for a defined period (e.g., 10-30 minutes) to allow for glycine uptake.
- Termination of Uptake:
  - Rapidly aspirate the uptake solution.
  - Wash the cells multiple times with ice-cold assay buffer to remove extracellular radiolabeled glycine.
- Cell Lysis and Scintillation Counting:
  - Lyse the cells using a suitable lysis buffer.
  - Transfer the cell lysate to scintillation vials.
  - Add scintillation cocktail and measure the radioactivity using a scintillation counter.
- Data Analysis:
  - Determine the specific glycine uptake by subtracting the non-specific uptake (measured in the presence of a high concentration of a known GlyT1 inhibitor or in mock-transfected cells) from the total uptake.
  - Calculate the percentage of inhibition for each concentration of **ALX-5407 hydrochloride** relative to the vehicle control.
  - Plot the percentage of inhibition against the log of the inhibitor concentration and fit the data to a four-parameter logistic equation to determine the IC<sub>50</sub> value.

## Mandatory Visualizations

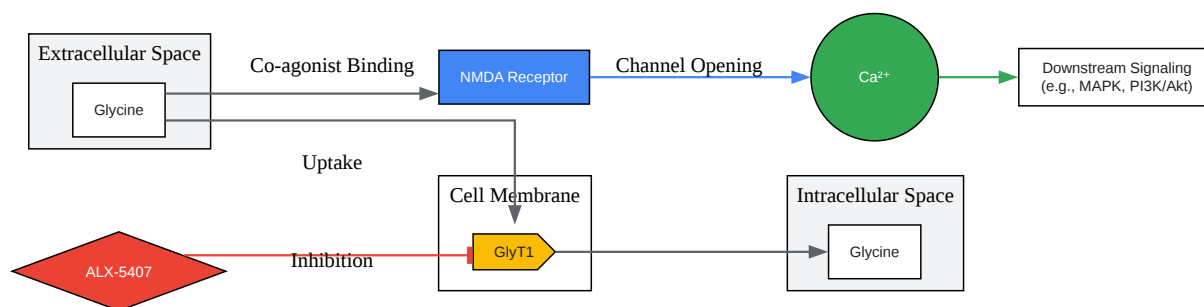

[Click to download full resolution via product page](#)

Caption: ALX-5407 inhibits GlyT1, increasing synaptic glycine and potentiating NMDA receptor signaling.

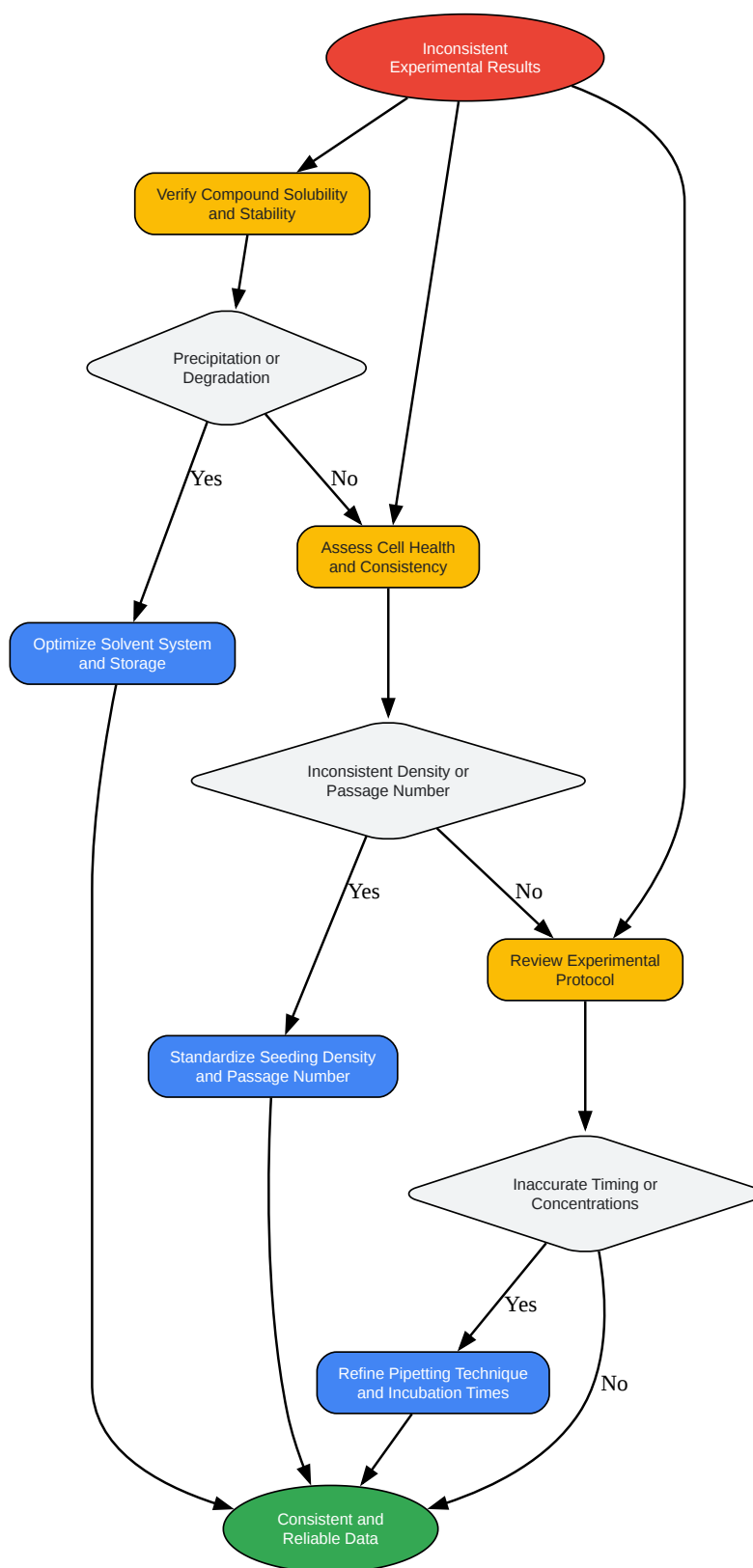

[Click to download full resolution via product page](#)

Caption: A logical workflow for troubleshooting variability in **ALX-5407 hydrochloride** experiments.

### *Need Custom Synthesis?*

*BenchChem offers custom synthesis for rare earth carbides and specific isotopic labeling.*

*Email: [info@benchchem.com](mailto:info@benchchem.com) or [Request Quote Online](#).*

## References

- [1. researchgate.net \[researchgate.net\]](#)
- [2. researchgate.net \[researchgate.net\]](#)
- [3. benchchem.com \[benchchem.com\]](#)
- [4. Glycine Transporter-1 Inhibition Promotes Striatal Axon Sprouting via NMDA Receptors in Dopamine Neurons - PMC \[pmc.ncbi.nlm.nih.gov\]](#)
- [5. Frontiers | Directly and Indirectly Targeting the Glycine Modulatory Site to Modulate NMDA Receptor Function to Address Unmet Medical Needs of Patients With Schizophrenia \[frontiersin.org\]](#)
- [6. Frontiers | Inhibition of astrocytic glycine transporter-1: friend or foe for ameliorating NMDA receptor hypofunction? \[frontiersin.org\]](#)
- [7. medchemexpress.com \[medchemexpress.com\]](#)
- [8. caymanchem.com \[caymanchem.com\]](#)
- [9. GlyT1 inhibition by ALX-5407 attenuates allograft rejection through suppression of Th1 cell differentiation - PMC \[pmc.ncbi.nlm.nih.gov\]](#)
- [10. Randomized Controlled Trial of the Glycine Transporter 1 Inhibitor PF-03463275 to Enhance Cognitive Training and Neuroplasticity in Schizophrenia - PMC \[pmc.ncbi.nlm.nih.gov\]](#)
- [11. Relationship Between Glycine Transporter 1 Inhibition as Measured with Positron Emission Tomography and Changes in Cognitive Performances in Nonhuman Primates - PMC \[pmc.ncbi.nlm.nih.gov\]](#)
- [12. ALX 5407: a potent, selective inhibitor of the hGlyT1 glycine transporter - PubMed \[pubmed.ncbi.nlm.nih.gov\]](#)
- [13. researchgate.net \[researchgate.net\]](#)

- To cite this document: BenchChem. [Technical Support Center: ALX-5407 Hydrochloride Experiments]. BenchChem, [2026]. [Online PDF]. Available at: [<https://www.benchchem.com/product/b030177/docs#technical-support-center-alx-5407-hydrochloride-experiments>]

---

### Disclaimer & Data Validity:

The information provided in this document is for Research Use Only (RUO) and is strictly not intended for diagnostic or therapeutic procedures. While BenchChem strives to provide accurate protocols, we make no warranties, express or implied, regarding the fitness of this product for every specific experimental setup.

**Technical Support:** The protocols provided are for reference purposes. Unsure if this reagent suits your experiment?

**Need Industrial/Bulk Grade?** [Request Custom Synthesis Quote](#)

## BenchChem

Our mission is to be the trusted global source of essential and advanced chemicals, empowering scientists and researchers to drive progress in science and industry.

### Contact

Address: 3281 E Guasti Rd  
Ontario, CA 91761, United States  
Phone: (601) 213-4426  
Email: [info@benchchem.com](mailto:info@benchchem.com)

[Contact our Ph.D. Support Team for a compatibility check](#)