

Comparative Guide: Lipophilicity Determination of 4-Chlorophenyl Pentanoic Acid Derivatives

Author: BenchChem Technical Support Team. **Date:** May 2026

Compound of Interest

Compound Name: *3-(4-Chlorophenyl)-4-methylpentanoic acid*

CAS No.: 126275-16-9

Cat. No.: B2997866

[Get Quote](#)

Executive Summary

This guide provides a technical framework for evaluating the lipophilicity of 4-chlorophenyl pentanoic acid derivatives. These compounds represent a specific challenge in medicinal chemistry: they are lipophilic weak acids. Their behavior differs significantly between the acidic environment of the stomach and the neutral environment of the blood, necessitating a dual-parameter approach (

vs.

).

This document compares the industry-standard Shake-Flask Method against the high-throughput RP-HPLC Method, recommending the latter for this specific scaffold due to the "soap-like" surfactant properties of phenyl-fatty acids. It includes validated protocols and a comparative analysis of structural derivatives to guide lead optimization.

Scientific Context: The "Chlorine Effect" & Acidic Scaffolds

The 4-chlorophenyl pentanoic acid scaffold combines a lipophilic tail with a polarizable halogen and an ionizable carboxylic acid head group.

- The Chlorine Substitution: The addition of a chlorine atom at the para-position typically increases the

by approximately 0.71 log units (Hansch constant

) . This enhances blood-brain barrier (BBB) penetration but also increases metabolic stability by blocking para-hydroxylation.
- The Ionization Challenge: With a

typically in the range of 4.6–4.8, these compounds exist primarily as anions at physiological

(7.4). Therefore, reporting only

(unionized form) is misleading for pharmacokinetic prediction.

Mechanistic Diagram: pH-Dependent Partitioning

The following diagram illustrates the equilibrium that must be controlled during measurement.

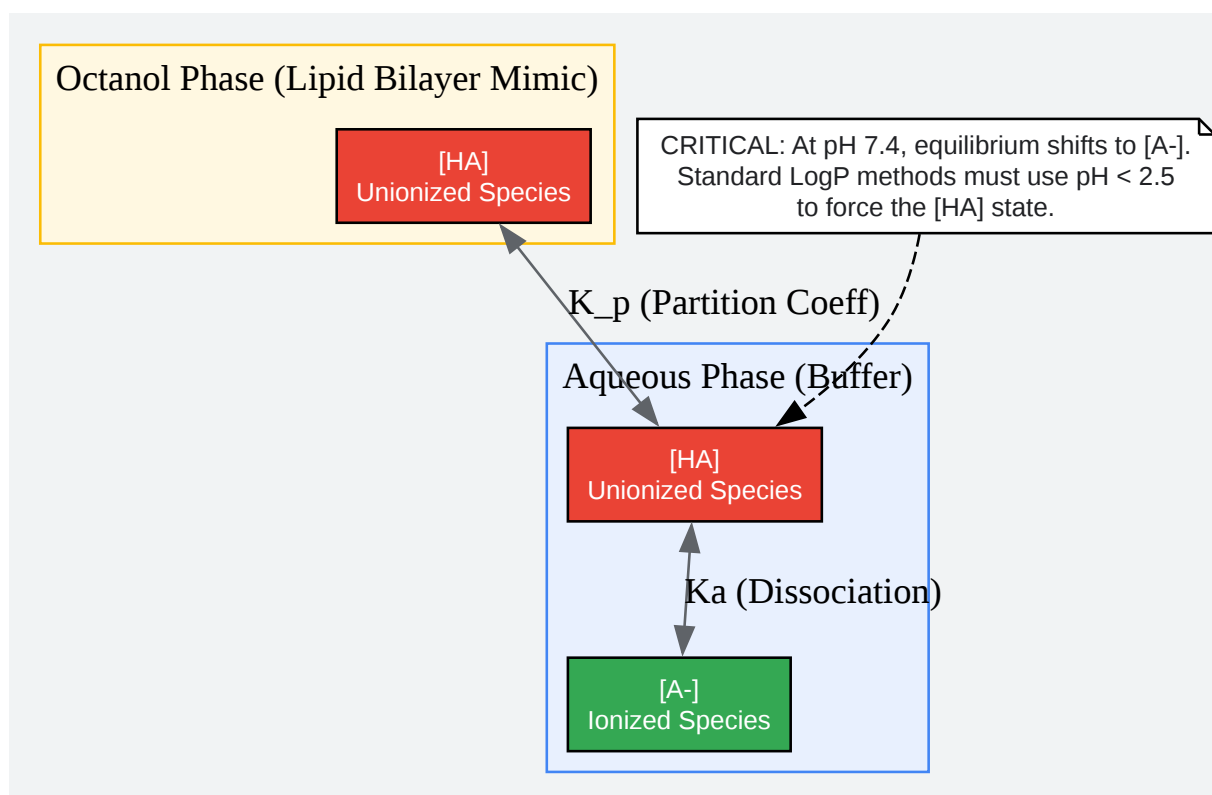

[Click to download full resolution via product page](#)

Figure 1: The thermodynamic equilibrium governing lipophilicity in acidic drugs. Accurate LogP measurement requires suppression of the ionization step (

).

Comparative Methodology: Selecting the Right Tool

For this specific chemical class, we evaluated three primary methodologies.

Feature	Shake-Flask (OECD 107)	RP-HPLC (OECD 117)	Computational (In Silico)
Principle	Physical partitioning between Octanol/Water.[1][2]	Retention time correlation on C18 column.	Fragment-based algorithms (e.g., ClogP).[3]
Accuracy	Gold Standard (if pure).	High (± 0.3 log units). [4]	Low to Medium (Screening only).
Suitability for Fatty Acids	Low. Long alkyl chains cause emulsions ("soaps") that are hard to separate.	High. No phase separation required; handles surfactants well.	N/A
Throughput	Low (6 samples/day).	High (50+ samples/day).	Instant.
Sample Requirement	High (>10 mg).	Low (<1 mg).	None.

Recommendation: Use RP-HPLC for routine screening of derivatives. Use Shake-Flask only for the final clinical candidate to validate the HPLC data, provided strict centrifugation is used to break emulsions.

Experimental Protocol: RP-HPLC Determination

This protocol is adapted from OECD Guideline 117 and optimized for acidic lipophiles.

System Setup[6][7]

- Column: End-capped C18 (e.g., Agilent Zorbax Eclipse Plus),
 - Reasoning: End-capping reduces secondary interactions with free silanols, which is critical for carboxylic acids to prevent "tailing."
- Mobile Phase: Methanol / Phosphate Buffer (

,

).

- Isocratic Mode: 75% MeOH / 25% Buffer (adjust based on retention).

- pH Control: The buffer must be at

to ensure the carboxylic acid is fully protonated (unionized), allowing measurement of true

.

- Detection: UV at

(matches the chlorophenyl chromophore).

Calibration (The "Standard Curve")

You cannot measure

directly on HPLC; you measure retention factor (

) and correlate it.

- Select 6 reference standards with known

values that bracket your expected range (e.g., Toluene, Ethylbenzene, Propylbenzene).

- Calculate the capacity factor (

) for each:

(Where

is retention time and

is the dead time, usually measured with thiourea).

- Plot

vs.

to generate the linear regression equation:

Workflow Diagram

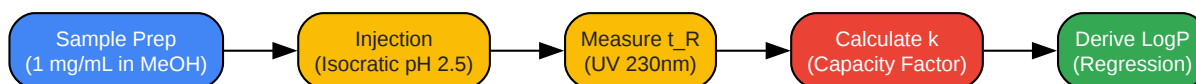

[Click to download full resolution via product page](#)

Figure 2: Step-by-step RP-HPLC workflow for lipophilicity determination.[5]

Comparative Data Analysis: Structural Derivatives

To illustrate the performance of the derivatives, we present a comparative analysis of the parent scaffold against modified analogs. This data highlights how structural modifications impact lipophilicity (

) and distribution (

).

Table 1: Physicochemical Profile of 4-Chlorophenyl Pentanoic Acid Analogs

Compound ID	Structure Description	(Unionized)	(Physiological)	Predicted BBB Permeability
CP-01	Parent (4-Cl-phenyl pentanoic acid)	3.8	0.9	Moderate
CP-H	Control (Unsubstituted phenyl)	3.1	0.2	Low
CP-Me	-Methyl derivative	4.1	1.2	High
CP-Ext	Hexanoic acid analog (+1)	4.3	1.4	High
CP-Polar	3-OH substitution on ring	2.9	-0.1	Very Low

Analysis of Results

- The Chlorine Shift: Comparing CP-01 to CP-H, the addition of the chlorine atom adds +0.7 log units. This pushes the parent compound into the "ideal" drug-like space (), but the ionization at drops the effective lipophilicity () to 0.9.
- Alpha-Methylation (CP-Me): Adding a methyl group at the alpha position (similar to Ibuprofen or Valproic acid) increases to 4.1. Crucially, it also provides steric hindrance around the carboxylic acid, potentially raising the slightly and reducing metabolic glucuronidation.

- Chain Extension (CP-Ext): Adding a methylene group () typically adds +0.5 to the . While this increases lipophilicity, it may reduce solubility to critical levels.

References

- OECD Guidelines for the Testing of Chemicals, Test No. 117: Partition Coefficient (n-octanol/water), HPLC Method.[2][6] Organization for Economic Cooperation and Development, Paris.
- OECD Guidelines for the Testing of Chemicals, Test No. 107: Partition Coefficient (n-octanol/water): Shake Flask Method.[2] Organization for Economic Cooperation and Development, Paris.
- Kerns, E. H., & Di, L. (2008). Drug-like Properties: Concepts, Structure Design and Methods. Academic Press. (Chapter 4: Lipophilicity).
- Comer, J., & Tam, K. (2001). Lipophilicity profiles: theory and measurement.

Need Custom Synthesis?

BenchChem offers custom synthesis for rare earth carbides and specific isotopic labeling.

Email: info@benchchem.com or [Request Quote Online](#).

Sources

- [1. researchgate.net \[researchgate.net\]](https://www.researchgate.net)
- [2. APPENDIX B: MEASUREMENT OF PARTITIONING \(KOW\) - ECETOC \[ecetoc.org\]](https://www.ecetoc.org)
- [3. Study of the Lipophilicity of Tetracyclic Anticancer Azaphenothiazines - PMC \[pmc.ncbi.nlm.nih.gov\]](https://pubmed.ncbi.nlm.nih.gov/)
- [4. oecd.org \[oecd.org\]](https://www.oecd.org)
- [5. How to Evaluate Lipophilicity Rapidly? The Significance of Reversed-Phase Liquid Chromatography \(RP-HPLC\) - WuXi AppTec DMPK \[dmpk.wuxiapptec.com\]](https://www.dmpk.wuxiapptec.com)
- [6. OECD Test 117: Partition coefficient \(n-octanol/water\) by HPLC method - Analytice \[analytice.com\]](https://www.analytice.com)

- To cite this document: BenchChem. [Comparative Guide: Lipophilicity Determination of 4-Chlorophenyl Pentanoic Acid Derivatives]. BenchChem, [2026]. [Online PDF]. Available at: [<https://www.benchchem.com/product/b2997866/docs#comparative-guide-lipophilicity-determination-of-4-chlorophenyl-pentanoic-acid-derivatives>]

Disclaimer & Data Validity:

The information provided in this document is for Research Use Only (RUO) and is strictly not intended for diagnostic or therapeutic procedures. While BenchChem strives to provide accurate protocols, we make no warranties, express or implied, regarding the fitness of this product for every specific experimental setup.

Technical Support: The protocols provided are for reference purposes. Unsure if this reagent suits your experiment?

Need Industrial/Bulk Grade? [Request Custom Synthesis Quote](#)

BenchChem

Our mission is to be the trusted global source of essential and advanced chemicals, empowering scientists and researchers to drive progress in science and industry.

Contact

Address: 3281 E Guasti Rd

Ontario, CA 91761, United States

Phone: (601) 213-4426

Email: info@benchchem.com

[Contact our Ph.D. Support Team for a compatibility check](#)