

Technical Support Center: Volatile Fluorinated Sulfur Intermediates

Author: BenchChem Technical Support Team. **Date:** April 2026

Compound of Interest

Compound Name: 2,4-Difluoro-1-(sulfinylamino)benzene
CAS No.: 88785-38-0
Cat. No.: B2990588

[Get Quote](#)

Current Status: Operational | Tier: Level 3 Specialist Support

Welcome to the Advanced Fluorination Safety & Handling Hub. This guide addresses the specific handling requirements for high-volatility sulfur-fluorine intermediates, primarily Sulfur Tetrafluoride (

) and Thionyl Fluoride (

). Unlike stable reagents, these intermediates possess a dual-hazard profile: extreme volatility combined with rapid hydrolysis to release anhydrous Hydrogen Fluoride (HF).

Module 1: Critical Engineering Controls (The "Dry Rig")

Objective: Prevent containment failure due to material incompatibility or moisture ingress.

Material Compatibility Matrix

The most common cause of failure we diagnose is the use of standard stainless steel in moisture-compromised lines.

itself is not corrosive to steel when perfectly dry, but it instantly generates HF upon contact with trace moisture, causing stress corrosion cracking.

Component	Recommended Material	Technical Rationale
Cylinder Valves	Monel 400	High nickel-copper content resists HF corrosion better than 316 SS.
Tubing (Flexible)	PFA / PTFE	Chemical inertness + Translucency (allows visual confirmation of liquid condensation).
Tubing (Rigid)	Hastelloy C-276	Superior resistance to pitting in acidic fluoride environments compared to SS.
Reactor Vessels	FEP/PFA Liners	Glass is strictly prohibited for storage; etching weakens structural integrity.
O-Rings	Kalrez / Chemraz	Standard Viton swells and degrades upon prolonged exposure to

The "Manifold" Setup Logic

Do not regulate flow using a simple needle valve. You must use a vacuum manifold system to handle these volatiles by pressure differential and condensation, not by positive pressure pushing.

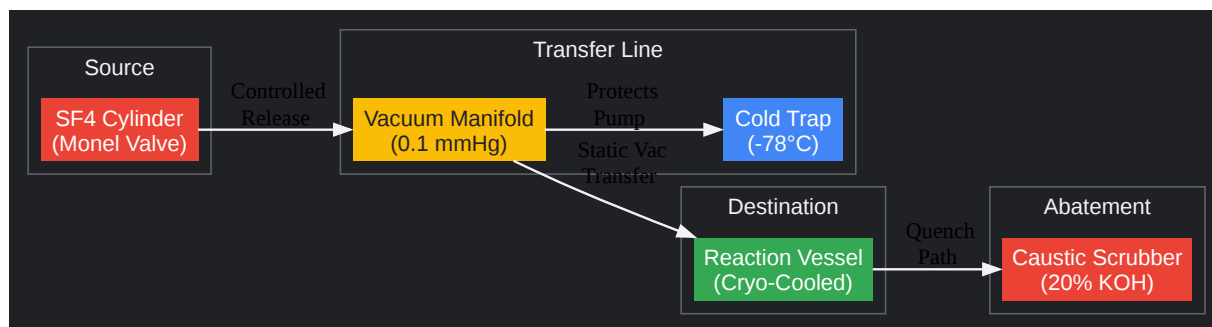

[Click to download full resolution via product page](#)

Figure 1: Vacuum Transfer Workflow. This setup relies on static vacuum transfer (condensing gas into the reactor) rather than positive pressure bubbling, minimizing leak risks.

Module 2: Synthesis & Handling Mechanics

Objective: Transfer volatile reagents without atmospheric exposure.

Protocol: Static Vacuum Condensation (The "Gold Standard")

Context: You need to add 50 mmol of

(gas) to a reaction vessel containing a substrate.

- Tare the Reactor: Weigh the empty FEP/PFA reactor vessel.
- Cool the Reactor: Immerse the reactor in a Liquid
or Dry Ice/Acetone bath (
)
).
- Establish Vacuum: Evacuate the manifold and the reactor line to

- Isolate Pump: Close the valve to the vacuum pump. The system is now under static vacuum.
- Transfer: Slowly open the cylinder. The gas will naturally migrate to the coldest point (your reactor) and condense into a liquid.
 - Visual Check: If using PFA tubing, you will see liquid collecting.
- Gravimetric Check: Close the reactor valve. Warm to room temperature (behind a blast shield) and weigh.
 - Why? Flow meters corrode. Weight is the only reliable metric for fluorinated gases.

Module 3: Troubleshooting & Emergency Response

Objective: Immediate identification and neutralization of containment breaches.

Diagnostic Flowchart: "I smell garlic/rotten eggs"

Note:

has a sulfurous odor; HF has a pungent, biting odor. If you smell either, you are already exposed.

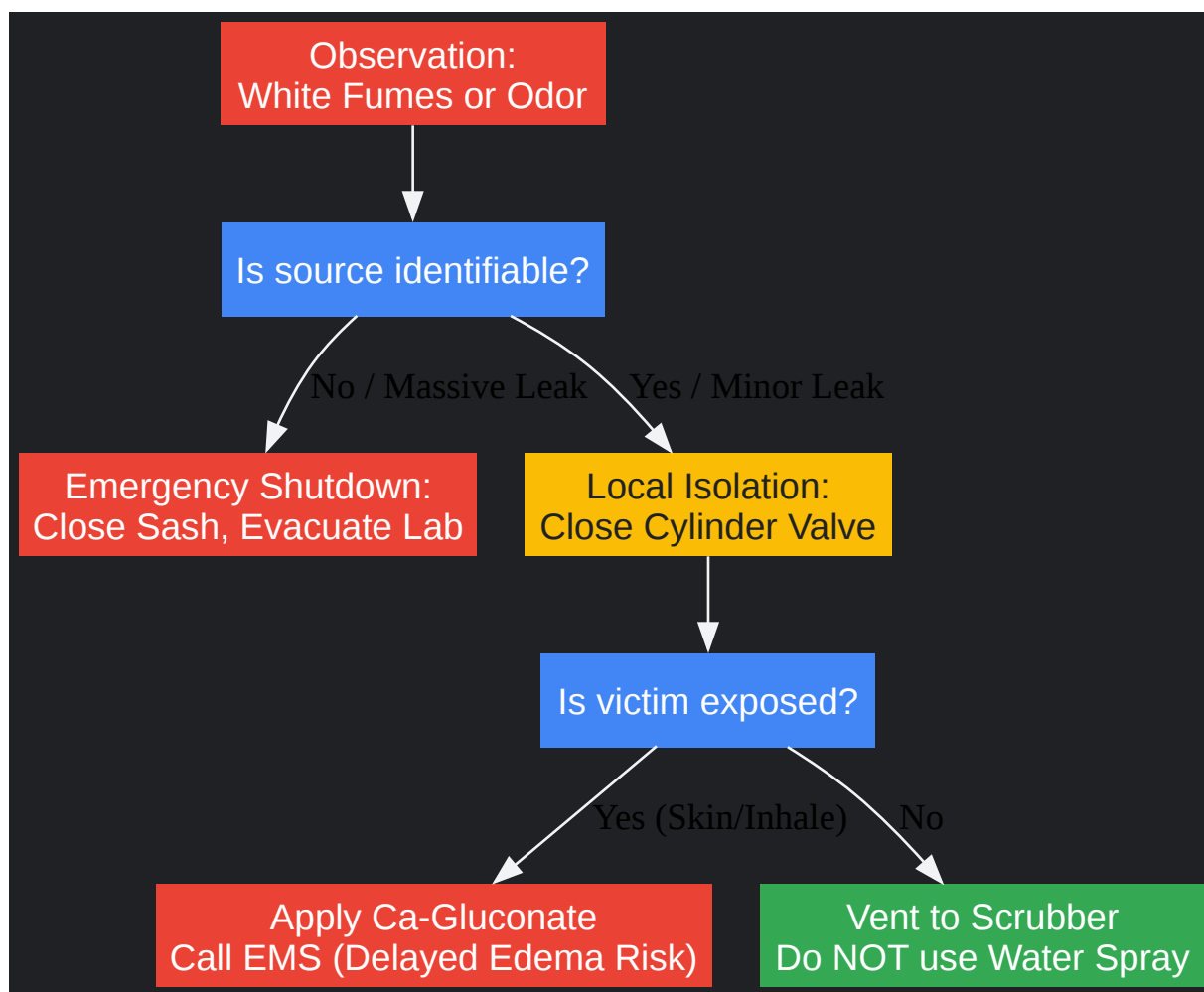

[Click to download full resolution via product page](#)

Figure 2: Leak Response Logic. Immediate distinction between containment and evacuation is vital.

Frequently Asked Questions (FAQ)

Q: My regulator is stuck. Can I use a wrench to force it? A: ABSOLUTELY NOT. A stuck valve on an

cylinder usually indicates internal corrosion (metal fluoride salts seizing the threads). Forcing it can snap the stem, causing an uncontrollable release of toxic gas.

- Solution: Contact the gas supplier for a hazardous cylinder return. Do not attempt to repair.

Q: Can I use a glass trap for the scrubber? A: Only if you want it to shatter. Hydrolysis of

produces HF:

The HF generated will etch glass rapidly, heating it up (exothermic) and potentially shattering the vessel.

- Solution: Use Polypropylene (PP) or HDPE buckets for scrubbers.

Q: What is the correct scrubber composition? A: 20% Potassium Hydroxide (KOH). NaOH is acceptable, but KOH is preferred because Potassium Fluoride (KF) is more soluble than Sodium Fluoride (NaF), preventing clogs in the sparger tube.

- Tip: Add a pH indicator (Phenolphthalein) to the scrubber to visually monitor exhaustion.

Q: I inhaled a small puff. I feel fine. Can I go home? A: No. You need medical observation.

and

cause delayed pulmonary edema. The hydrolysis in the lungs is slow. You may feel fine for 4-8 hours, then "drown" in your own fluids as fluid accumulates in the alveoli.

- Protocol: Immediate transport to ER; inform them of "Delayed Pulmonary Edema risk from Fluoride/Acid gas."

Module 4: Waste Disposal & Decontamination

Objective: Safely quench residual reactive intermediates.

The "Double-Quench" Method: Never quench

directly with water. The reaction is too violent.

- Dilution: Flush the system with dry Nitrogen () to dilute the remaining .
- Surface Quench: Pass the gas stream through a bed of Soda Lime (solid) first to catch the bulk of the fluorides.

- Final Scrubber: Bubble the exhaust into 20% KOH solution.

References

- American Chemical Society (ACS). Sulfur Tetrafluoride (SF₄) as a Deoxyfluorination Reagent for Organic Synthesis in Continuous Flow Mode. Org.[1] Process Res. Dev. 2023. [[Link](#)]
- New Jersey Department of Health. Hazardous Substance Fact Sheet: Sulfur Tetrafluoride. [[Link](#)]

Need Custom Synthesis?

BenchChem offers custom synthesis for rare earth carbides and specific isotopic labeling.

Email: info@benchchem.com or [Request Quote Online](#).

Sources

- [1. synquestlabs.com](https://www.synquestlabs.com) [[synquestlabs.com](https://www.synquestlabs.com)]
- To cite this document: BenchChem. [Technical Support Center: Volatile Fluorinated Sulfur Intermediates]. BenchChem, [2026]. [Online PDF]. Available at: [<https://www.benchchem.com/product/b2990588/docs#technical-support-center-volatile-fluorinated-sulfur-intermediates>]

Disclaimer & Data Validity:

The information provided in this document is for Research Use Only (RUO) and is strictly not intended for diagnostic or therapeutic procedures. While BenchChem strives to provide accurate protocols, we make no warranties, express or implied, regarding the fitness of this product for every specific experimental setup.

Technical Support: The protocols provided are for reference purposes. Unsure if this reagent suits your experiment?

Need Industrial/Bulk Grade? [Request Custom Synthesis Quote](#)

BenchChem

Our mission is to be the trusted global source of essential and advanced chemicals, empowering scientists and researchers to drive progress in science and industry.

Contact

Address: 3281 E Guasti Rd

Ontario, CA 91761, United States

Phone: (601) 213-4426

Email: info@benchchem.com

[Contact our Ph.D. Support Team for a compatibility check](#)