

Technical Support Center: Handling Hygroscopic Boc-Protected Amino Alcohols

Author: BenchChem Technical Support Team. **Date:** April 2026

Compound of Interest

Compound Name: *Boc-D-Dab(Z)-Ol*

CAS No.: 197892-17-4

Cat. No.: B2985328

[Get Quote](#)

Executive Summary & Scope

N-Boc-amino alcohols (e.g., N-Boc-prolinol, N-Boc-phenylalaninol) are critical chiral building blocks in peptide mimetics and drug discovery. While the tert-butyloxycarbonyl (Boc) group provides robust protection against basic and nucleophilic attack, the amino alcohol moiety renders these compounds significantly hygroscopic.

This guide addresses the three most common user challenges:

- Physical State Alteration: Crystalline solids turning into sticky gums or oils.
- Stoichiometric Errors: Water weight inflating mass, leading to under-loading of reagents.
- Reaction Failure: Trace moisture quenching water-sensitive downstream chemistries (e.g., Mitsunobu, Swern oxidation).

Diagnostic FAQs: Is My Reagent Compromised?

Q1: My Boc-amino alcohol arrived as a viscous oil, but the CoA says "Solid." Has it degraded?

Diagnosis: Likely No. Explanation: Many Boc-amino alcohols have low melting points (30–50°C). During transit, temperature fluctuations can melt the solid. Because these compounds are hygroscopic, they absorb atmospheric moisture, which acts as a plasticizer and prevents re-crystallization, leaving you with a supercooled liquid or "gum." Action: Check purity via NMR (

H) or TLC. If the Boc signals (

ppm) and core structure are intact, the compound is chemically stable but physically hydrated. See Protocol A (Drying).

Q2: Can I just use the "wet" reagent if I adjust the molecular weight? Diagnosis: Risk High.

Explanation: While you can correct for mass, the free water is a reactive impurity.

- In Peptide Coupling: Water hydrolyzes activated esters (e.g., NHS-esters), reducing yield.
- In Mitsunobu Reactions: Water is a competitive nucleophile, consuming DEAD/DIAD and Triphenylphosphine to form hydrazine byproducts rather than your desired ether/ester [1].

Q3: Is the Boc group falling off due to the moisture? Diagnosis: Unlikely. Explanation: The Boc group is acid-labile (cleaved by TFA/HCl). It is generally stable to neutral water and hydrolysis at pH 7.[1] The primary risk of moisture is not deprotection, but interference with subsequent reactions [2].

Remediation Protocols: Drying the Reagent[2][3][4]

If your reagent is wet (sticky solid or oil), standard vacuum drying is often insufficient because the water is trapped in the viscous matrix.

Protocol A: Azeotropic Distillation (For Oils/Gums)

The most effective method for removing water from viscous Boc-amino alcohols.

Principle: Water forms a low-boiling azeotrope with toluene (bp 85°C) or benzene (bp 69°C), allowing it to be "carried" out of the oil [3].

- Dissolution: Dissolve the viscous Boc-amino alcohol in Anhydrous Toluene (approx. 10 mL per gram of reagent).
 - Note: Toluene is preferred over Benzene due to lower toxicity, though Benzene is more efficient for lyophilization.
- Evaporation: Rotovap the solution at 40–45°C under reduced pressure.
- Repetition: Repeat step 1 and 2 three times. This "chasing" technique ensures quantitative water removal.
- Final Dry: Place the flask on a high-vacuum manifold (< 0.1 mbar) for 4–6 hours to remove trace toluene.
- Result: The oil should become more viscous or solidify into a foam/crust.

Protocol B: Lyophilization (For Heat-Sensitive Solids)

Best for reagents that must remain solid for weighing.

- Dissolve the material in 1,4-Dioxane or tert-Butanol (both freeze well and sublime).
- Freeze the solution in a bath of dry ice/acetone.
- Connect to a lyophilizer (freeze-dryer) for 24–48 hours.
- Result: A fluffy, dry powder that is easy to weigh.

Handling & Weighing Workflows

Avoid weighing hygroscopic Boc-amino alcohols on open balance pans. The static charge and moisture uptake will result in significant errors.

Decision Tree: Handling Strategy

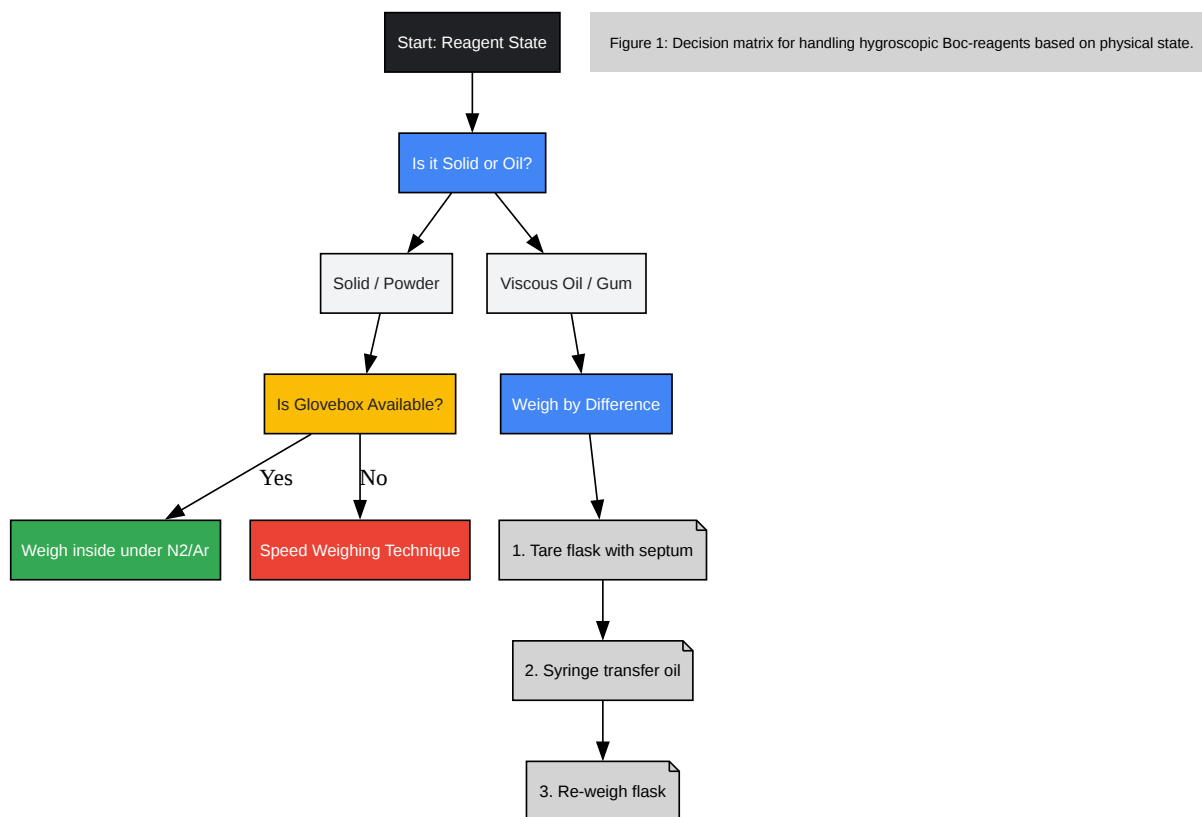

[Click to download full resolution via product page](#)

The "Weighing by Difference" Technique (For Oils)

- Tare a dry round-bottom flask (RBF) with a septum cap.
- Take your source container of Boc-amino alcohol. If it is too viscous, warm it slightly (30°C) or add a known volume of dry solvent (e.g., DCM) to create a stock solution.

- Use a wide-bore needle or glass pipette to transfer the approximate amount into the tared RBF.
- Weigh the RBF again. The difference is your reagent mass.
- Crucial: Immediately flush the source container with Argon/Nitrogen and seal with Parafilm.

Impact of Moisture on Downstream Chemistry

The presence of water is not just a purity issue; it fundamentally alters reaction pathways.

Table 1: Water Tolerance in Common Boc-Amino Alcohol Reactions

Reaction Type	Sensitivity	Mechanism of Failure	Recommended Max Water
Mitsunobu Reaction	Critical	Water acts as a nucleophile, consuming DEAD/PPh ₃ to form hydrazine. Reaction stalls or yields side products.[2]	< 0.05%
Swern Oxidation	Critical	Water quenches the sulfonium intermediate, preventing alcohol oxidation to aldehyde.	< 0.1%
Peptide Coupling	Moderate	Water hydrolyzes active esters (e.g., O-acylisourea), reducing coupling efficiency.	< 1.0%
Alkylation (NaH)	High	Water reacts violently with NaH, consuming base and potentially causing fire.	0% (Strictly Anhydrous)

Visualizing the Failure Mode (Mitsunobu)

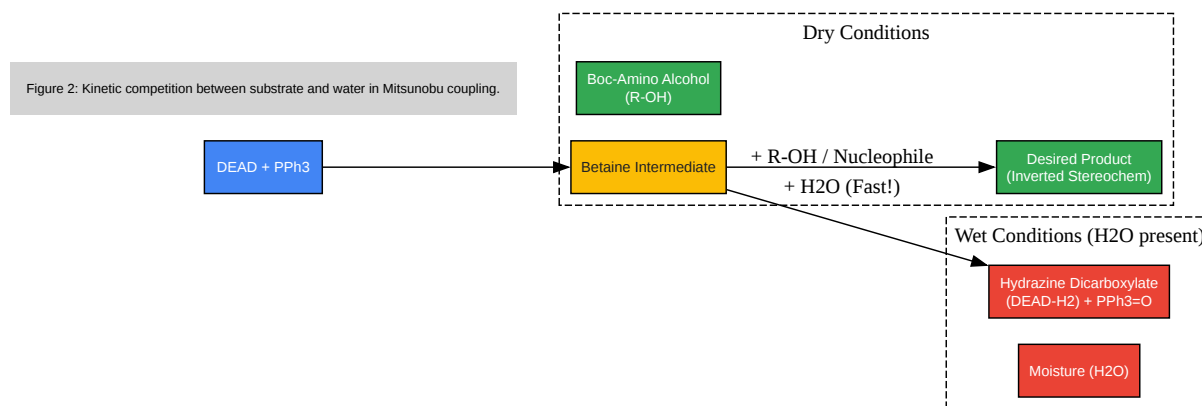

[Click to download full resolution via product page](#)

Storage Best Practices

To prevent degradation and hydration cycles:

- Temperature: Store at -20°C. Low temperature reduces the rate of any potential hydrolysis and keeps the material solid (if the MP is near RT).
- The "Warm-Up" Rule: Never open a cold bottle of hygroscopic reagent in the lab atmosphere.
 - Protocol: Remove bottle from freezer -> Place in a desiccator -> Allow to reach Room Temperature (approx. 30-60 mins) -> Open.
 - Why? Opening a cold bottle causes immediate condensation of atmospheric moisture onto the reagent surface [4].

- Secondary Containment: Store the primary vial inside a jar containing desiccant packets (Silica gel or Drierite).

References

- Mitsunobu, O. (1981).[3] "The Use of Diethyl Azodicarboxylate and Triphenylphosphine in Synthesis and Transformation of Natural Products." *Synthesis*, 1981(1), 1-28. [Link](#)
- BenchChem. (2025).[1] "Navigating the Stability and Storage of t-Boc-Aminoxy-PEG3-alcohol: An In-depth Technical Guide." *BenchChem Technical Guides*. [Link](#)
- Perrin, D. D., & Armarego, W. L. F. (1988). *Purification of Laboratory Chemicals*. Pergamon Press. (Standard reference for azeotropic drying of organic reagents).
- Sigma-Aldrich. (2023). "Handling and Storage of Hygroscopic Reagents." *Technical Bulletin*. [Link](#)

Need Custom Synthesis?

BenchChem offers custom synthesis for rare earth carbides and specific isotopic labeling.

Email: info@benchchem.com or [Request Quote Online](#).

Sources

- 1. pdf.benchchem.com [pdf.benchchem.com]
- 2. [Boc Resin Cleavage Protocol](https://www.sigmaaldrich.com) [[sigmaaldrich.cn](https://www.sigmaaldrich.com)]
- 3. [tcichemicals.com](https://www.tcichemicals.com) [[tcichemicals.com](https://www.tcichemicals.com)]
- To cite this document: BenchChem. [Technical Support Center: Handling Hygroscopic Boc-Protected Amino Alcohols]. BenchChem, [2026]. [Online PDF]. Available at: [<https://www.benchchem.com/product/b2985328/docs#technical-support-center-handling-hygroscopic-boc-protected-amino-alcohols>]

Disclaimer & Data Validity:

The information provided in this document is for Research Use Only (RUO) and is strictly not intended for diagnostic or therapeutic procedures. While BenchChem strives to provide accurate protocols, we make no warranties, express or implied, regarding the fitness of this product for every specific experimental setup.

Technical Support: The protocols provided are for reference purposes. Unsure if this reagent suits your experiment?

Need Industrial/Bulk Grade? [Request Custom Synthesis Quote](#)

BenchChem

Our mission is to be the trusted global source of essential and advanced chemicals, empowering scientists and researchers to drive progress in science and industry.

Contact

Address: 3281 E Guasti Rd
Ontario, CA 91761, United States
Phone: (601) 213-4426
Email: info@benchchem.com

[Contact our Ph.D. Support Team for a compatibility check](#)